

Area in Need of Redevelopment Investigation for Block 4905, Lots 1 - 22.01 | Township of Teaneck, New Jersey



Prepared on behalf of the
Township of Teaneck Planning Board by

PHILLIPS PREISS GRYGIEL LEHENY HUGHES LLC
Planning and Real Estate Consultants

August 2022

Area in Need of Redevelopment Investigation
Blocks 4905, Lots 1-15 & 17-22.01
West Englewood Avenue & Teaneck Road

Township of Teaneck, New Jersey

August 2022

Prepared for the:

The Township of Teaneck Planning Board

Prepared by:

Phillips Preiss Grygiel Leheny Hughes LLC
Planning and Real Estate Consultants
70 Hudson Street, Suite 5B
Hoboken, NJ 07030

The original of this report was signed and sealed in accordance with N.J.S.A. 13:41-1.2



Keenan Hughes, AICP, PP
New Jersey Professional Planner License # 6169



Spach Trahan, AICP, PP
New Jersey Professional Planner License #6435

TABLE OF CONTENTS

| | | |
|------------|---|-----------|
| I | INTRODUCTION | 1 |
| II | STUDY AREA LOCATIONAL CONTEXT | 2 |
| III | EXISTING ZONING AND MASTER PLAN DESIGNATIONS FOR THE STUDY AREA | 7 |
| A. | ZONING | 7 |
| | <i>R-S Residential Single-Family Residential District</i> | 7 |
| | <i>P Public Land District</i> | 7 |
| | <i>B-R Special Business - Residential District</i> | 7 |
| | <i>Other Ordinance Provisions</i> | 8 |
| B. | MASTER PLAN | 8 |
| IV | STATUTORY CRITERIA FOR ESTABLISHMENT OF AN AREA IN NEED OF REDEVELOPMENT AND APPLICATION TO THE STUDY AREA | 11 |
| V | STUDY AREA DESCRIPTION AND EVALUATION | 13 |
| A. | INDIVIDUAL PROPERTY EVALUATIONS | 13 |
| | <i>Block 4905, Lot 1 - 61 Graham Place</i> | 13 |
| | <i>Block 4905, Lot 2 - 1347 Mersereau Terrace</i> | 14 |
| | <i>Block 4905, Lot 3 - 54 West Englewood Avenue</i> | 15 |
| | <i>Block 4905, Lot 4.01 - 44 West Englewood Avenue</i> | 16 |
| | <i>Block 4905, Lot 5 - 40 West Englewood Avenue</i> | 16 |
| | <i>Block 4905, Lot 6 - 32 West Englewood Avenue</i> | 17 |
| | <i>Block 4905, Lot 7 - 26 West Englewood Avenue</i> | 17 |
| | <i>Block 4905, Lot 8 - 22 West Englewood Avenue</i> | 19 |
| | <i>Block 4905, Lot 9 - 20 West Englewood Avenue</i> | 21 |
| | <i>Block 4905, Lot 10 - 18 West Englewood Avenue</i> | 22 |
| | <i>Block 4905, Lot 11 - 1360-1364 Teaneck Road</i> | 23 |
| | <i>Block 4905, Lot 12 - 1354-1358 Teaneck Road</i> | 24 |
| | <i>Block 4905, Lot 13 - 1348-1352 Teaneck Road</i> | 26 |
| | <i>Block 4905, Lot 14 - 1344 Teaneck Road</i> | 27 |
| | <i>Block 4905, Lot 15 - 1338-1340 Teaneck Road</i> | 27 |
| | <i>Block 4905, Lot 17 - 1334 Teaneck Road</i> | 28 |
| | <i>Block 4905, Lot 18 - 23 Orchard Street</i> | 29 |
| | <i>Block 4905, Lot 19 - 27 Orchard Street</i> | 29 |
| | <i>Block 4905, Lot 20 - 35 Orchard Street</i> | 30 |
| | <i>Block 4905, Lot 21 - 43 Orchard Street</i> | 30 |
| | <i>Block 4905, Lot 22.01 - 1335 Graham Place</i> | 31 |
| B. | ANALYSIS OF THE STUDY AREA AS A WHOLE..... | 31 |
| VI | CONCLUSION | 34 |
| | APPENDICES..... | 35 |

LIST OF FIGURES

| | |
|--|----|
| Figure 1. Study Area Location | 4 |
| Figure 2. Tax Map | 5 |
| Figure 3. Aerial Context | 6 |
| Figure 4. Study Area Zoning..... | 10 |
| Figure 5. Area in Need of Redevelopment Criteria | 33 |

I INTRODUCTION

The following study has been prepared at the direction of the Council of the Township of Teaneck and on behalf of the Township of Teaneck Planning Board to determine whether a Study Area, or any portion thereof, consisting of Block 4905, Lots 1-15 & 17-22.01 within the Township of Teaneck qualifies as an “area in need of redevelopment” as defined under the Local Redevelopment and Housing Law (“LRHL”) at N.J.S.A. 40A:12A. Pursuant to Resolution #127-2022 dated May 17, 2022, the Township of Teaneck authorized the Planning Board to undertake this study for Block 4905, Lots 1 through 22.01. Resolution #129-2022, with the same date, authorized Phillips Preiss Grygiel Leheny Hughes LLC to undertake the study on behalf of the Planning Board. Pursuant to Section 6 of LRHL, the Township determined that such area would be a “Non-Condensation Redevelopment Area” if determined to satisfy the LRHL criteria. Therefore, designation as an area in need of redevelopment would authorize the Township to use all those powers provided by the Legislature for use in a redevelopment area, other than the use of eminent domain.

In preparation of the study, Phillips Preiss Grygiel Leheny Hughes LLC (Phillips Preiss) conducted the following investigations:

- Site investigation and physical inspection of the properties.
- Review of the 2007 Master Plan and Master Plan Reexamination Reports in 2011, 2014, and 2017.
- Review of the current zoning map and ordinances of the Township of Teaneck.
- Review of tax maps of the Township of Teaneck and tax records of the subject properties.
- Review of public records and additional property information, including Health Department violations, Police Department records, Building Department permits, Tax Assessor property cards, etc.

The remainder of this report is divided into six chapters. Chapter II provides an overview of the Study Area and its locational context. Chapter III provides an analysis of the applicable master plan and zoning designations within the Study Area. Chapter IV discusses the qualifying criteria set forth at N.J.S.A. 40A:12A-5 for an “area in need of redevelopment” determination. Chapter V describes the Study Area properties in detail and applies the criteria to determine whether or not an area in need of redevelopment determination is warranted. Chapter VI summarizes the overall conclusions of the report.

II STUDY AREA LOCATIONAL CONTEXT

The Study Area under consideration for redevelopment area designation consists of a total of 23 parcels (see Table 1). The Study Area is bound by West Englewood Avenue to the north; Teaneck Road to the east; Orchard Street, Graham Place, and single-family lots on Block 4904 to the south; and Mersereau Terrace to the west. **Figure 1: Location** shows the location of the Study Area in the Township, **Figure 2: Tax Map** depicts the tax map designations, and **Figure 3: Aerial Context** shows the surrounding aerial context.

The street address and ownership information for the parcels which comprise the Study Area are shown in **Table 1** below.

Table 1: Study Area Properties

| Block | Lot | Address | Current/Former Use | Prop. Class | Owner | Zone | Acres |
|-------|-------------------|---|--|-------------|---|------|-------|
| 4905 | 1 | 61 GRAHAM PL | Residence | 2 | DRASKIN, PETER | R-S | 0.197 |
| 4905 | 2 | 1347 MERSEREAU TERR | Residence, vacant | 2 | 54 WEST ENGLEWOOD AVE LLC | R-S | 0.09 |
| 4905 | 3 | 54 W ENGLEWOOD AVE | Residence, vacant | 2 | SADIQUILLA, MOHAMMED | R-S | 0.353 |
| 4905 | 4.01 | 44 W ENGLEWOOD AVE | Residence | 2 | ORDUKHANYAN, ASHOT | R-S | 0.177 |
| 4905 | 5 | 40 W ENGLEWOOD AVE | Residence, vacant | 2 | 40 WEST ENGLEWOOD LLC | R-S | 0.212 |
| 4905 | 6 | 32 W ENGLEWOOD AVE | Residence | 2 | KEITT, STEPHEN | R-S | 0.279 |
| 4905 | 7 | 26 W ENGLEWOOD AVE | Residence | 2 | STEIN, MENACHEM | R-S | 0.270 |
| 4905 | 8 | 22 W ENGLEWOOD AVE | Residence | 2 | STEIN, MENACHEM | B-R | 0.255 |
| 4905 | 9 | 20 W ENGLEWOOD AVE | Residence | 2 | STEIN, MENACHEM | B-R | 0.207 |
| 4905 | 10 | 18 W ENGLEWOOD AVE | Residence | 2 | ALVARADO, ANA ETAL | B-R | 0.152 |
| 4905 | 11-C0001 to C0003 | 1360 TEANECK RD (a.k.a. 1364 TEANECK RD); 1362 TEANECK RD; 1364 TEANECK RD (a.k.a. 1360 TEANECK RD) | Former Krispy Krunchy Chicken and Lahore Biryani & Grill (now vacant), Ebony Beauty Supplies | 4A | JUNG, JOOHO & LEE CHONG IM; JOOHO JUNG & CHONG IM LEE; IM, JENNY GIWON & DANIEL | B-R | 0.074 |
| 4905 | 12 | 1354-1358 TEANECK RD | Former Ana S Beauty Salon (now vacant), Former H&R Discount Liquors (now vacant), Kimmy's Beauty Spa Nails, Reggae Kitchen | 4A | WEL MANAGED RLTY & LEVIE, WARREN | B-R | 0.103 |
| 4905 | 13 | 1348-1352 TEANECK RD | H&S Discount Liquors, Blimpie and Surf City Squeeze, parking | 4A | JALASAI LLC | B-R | 0.220 |
| 4905 | 14 | 1344 TEANECK RD | Municipal parking lot | 15C | TOWNSHIP OF TEANECK | P | 0.455 |

AREA IN NEED OF REDEVELOPMENT INVESTIGATION | BLOCK 4905, LOTS 1-15 & 17-22.01, TOWNSHIP OF TEANECK, NJ

| | | | | | | | |
|--------------|-------|----------------------|---|----|---|-----|--------------|
| 4905 | 15 | 1338-1340 TEANECK RD | Office and retail: Leasco, Unique Styles Beauty Salon, Build Insurance Brokers, Access Computer Systems; parking garage and lot | 4A | PERSAUD, SOOKDEO | B-R | 0.114 |
| 4905 | 17 | 1334 TEANECK RD | Elsa's Beauty Salon II; apartment; parking garage and lot | 4A | MARTINEZ, DIOSMARY | B-R | 0.065 |
| 4905 | 18 | 23 ORCHARD ST | Residence | 2 | LONDON, JAN | B-R | 0.178 |
| 4905 | 19 | 27 ORCHARD ST | Residence | 2 | SOLARTE, JIMMY & FRIAS, JOANNA VARGAS | R-S | 0.176 |
| 4905 | 20 | 35 ORCHARD ST | Residence | 2 | STEIN, MENACHEM | R-S | 0.349 |
| 4905 | 21 | 43 ORCHARD ST | Residence | 2 | HOWARD, BEN C. & MELISSA B. | R-S | 0.341 |
| 4905 | 22.01 | 1335 GRAHAM PL | Residence | 2 | MCKENZIE, DIMIAN & SHAREE | R-S | 0.177 |
| TOTAL | | | | | | | ±4.44 |

Source: New Jersey Division of Taxation Property Tax List; Township of Teaneck Zoning Map, last revised February 2014.

Note: Total area may not sum due to rounding.

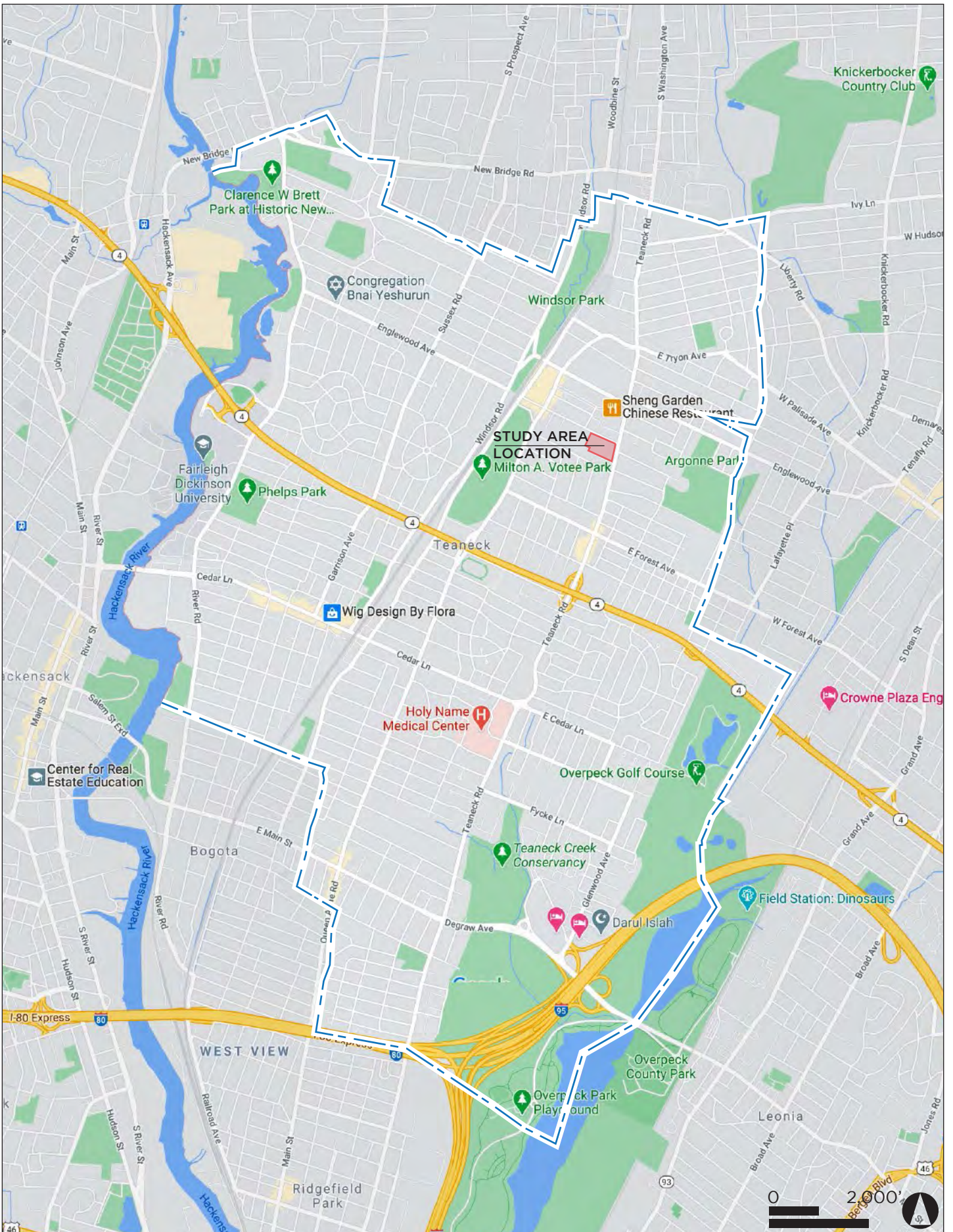

Figure 1: Location
 Area in Need of Redevelopment Investigation
 Block 4905, Lots 1 - 22.01 | Township of Teaneck, New Jersey



Figure 2: Tax Map
 Area in Need of Redevelopment Investigation
 Block 4905, Lots 1 - 22.01 | Township of Teaneck, New Jersey



Figure 3: Aerial Context
Area in Need of Redevelopment Investigation
Block 4905, Lots 1 - 22.01 | Township of Teaneck, New Jersey

III EXISTING ZONING AND MASTER PLAN DESIGNATIONS FOR THE STUDY AREA

A. Zoning

The Study Area is designated within multiple zoning districts, including a mix of residential, commercial, and public use zones. The following sections describe the existing underlying zoning districts. See **Figure 4: Existing Zoning**.

R-S Residential Single-Family Residential District

(Block 4905, Lots 1-7, 19-22.01)

The R-S District only permits single-family detached dwellings as principal uses. Permitted conditional uses are as follows:

- Home professional offices employing two persons but no more than six persons other than the resident professional, subject to the provisions of § 33-25.
- Public and private nursery, elementary and secondary schools, but not trade or business schools, subject to the provisions of § 33-25.
- Quasi-public buildings and recreation areas, subject to the provisions of § 33-25.
- Houses of religious worship, subject to the provisions of § 33-25.

This zone also allows a wide range of accessory uses associated with single-family residences.

P Public Land District

(Block 4905, Lot 14)

The purpose of the P District “is to restrict development on public lands which are in use as schools, administrative facilities, parking lots, libraries and other public buildings and structures.” Permitted principal uses, includes public schools, administrative facilities, libraries, recreational facilities, parking lots, wireless communication towers and antennas, and other public buildings and structures. No dimensional, density, or bulk restrictions are established for this zone, nor are there supplementary provisions or requirements.

B-R Special Business – Residential District

(Block 4905, Lots 8-13, 15-18)

The B-R District permits single-family attached and detached dwellings, two-family dwellings, offices and business schools on upper floors along the Teaneck Road frontage, restaurants, funeral homes, theaters and assembly halls, financial institutions; and government buildings, retail sales of goods and services, public and private schools, and child care centers subject to conditional use standards. Conditional uses are those permitted in the RC-1 Redevelopment Commercial-

Office/Retail District, which includes public utility institutions and wireless communications towers and antennas.

Other Ordinance Provisions

Sections 32-30 and 32-31 of the Township of Teaneck Ordinance establishes standards for upkeep of sidewalks and indicates that “upon receipt of written notice from the Township Engineer, [a property owner shall] replace or cause such sidewalk to be replaced and made in a good and passable condition so as to conform with the requirements of this article.”

B. Master Plan

The last comprehensive Master Plan for Teaneck was adopted in 2007 and was reexamined in 2011, 2014, and 2017. Several goals, objectives, and issues were raised in these reports that relate to the Study Area.

The Master Plan notes that a long stretch of Teaneck Road is one of two major commercial corridors in the Township. The Teaneck Road portion of the Study Area is located in this corridor. It is characterized as being an auto-oriented retail corridor, with a high volume of regional traffic. There is an array of retail, office, and institutional uses, and parking is found on the street or in small, dispersed parking lots. The plan is critical of the scattered and fragmented nature of the Teaneck Road north corridor, and notes that although building conditions are “not poor,” the streetscape and building facades are not particularly attractive. The plan recommends incentivizing redevelopment through modifications to use, bulk, parking, and design standards. It also notes that there are opportunities to add upper floors that accommodate residential, large-scale commercial, entertainment, and office uses. Specifically, it recommended permitting mixed-use development up to three stories and 35 feet high with zero-foot setbacks and pedestrian-focused amenities. However, mixed-use residential and retail/office development is currently a prohibited use in the B-R zone on Teaneck Road.

Several goals and objectives of the 2017 Master Plan Reexamination report are applicable to the Study Area and generally echo those listed in the 2007 Master Plan:

- Preserve the character of existing low-density residential neighborhoods forming the predominant character of the Township.
- Preserve and enhance the low-density residential character of established neighborhoods.
- Maintain a reasonable balance of housing choices, and provide for in-fill development, adaptive reuse and affordable senior housing.
- Protect neighborhood characteristics including the enforcement of buffer areas between non-residential and residential land uses, between different residential types, and along sensitive ecological areas of the Township.

- Provide zoning protection for existing multi-family housing and encourage its expansion only in areas where it would not have a detrimental effect on existing single-family residential neighborhoods.
- Focus economic development efforts on existing commercial, industrial and office districts and provide support and reinforcement to the four Business Districts to improve their viability.
- Provide for the Township's fair share of affordable housing as may be required by law as set forth in the Housing Plan Element.
- Promote a diversified economic base.

The 2017 Reexamination reported "no major new commercial development of note" in the Township since the 2014 Reexamination. Only minor renovations to existing developments and a handful of new one-off commercial applications were reviewed or approved. In terms of circulation, in 2016 the Township completed a plan for streetscape improvements on Teaneck Road and set aside \$1 million in funding to implement the plan.

The Housing Element and Fair Share Plan of 2019 adopted a Township-wide mandatory affordable housing set-aside ordinance, which requires 15 percent of dwelling units be set aside as affordable in rental projects and 20 percent to be set aside in ownership projects. This requirement is applicable to all residential projects that contemplate at least five dwelling units that are created through a rezoning, Zoning Board action, use or density variance, redevelopment plan, or rehabilitation plan for projects with a density of at least six units per acre.

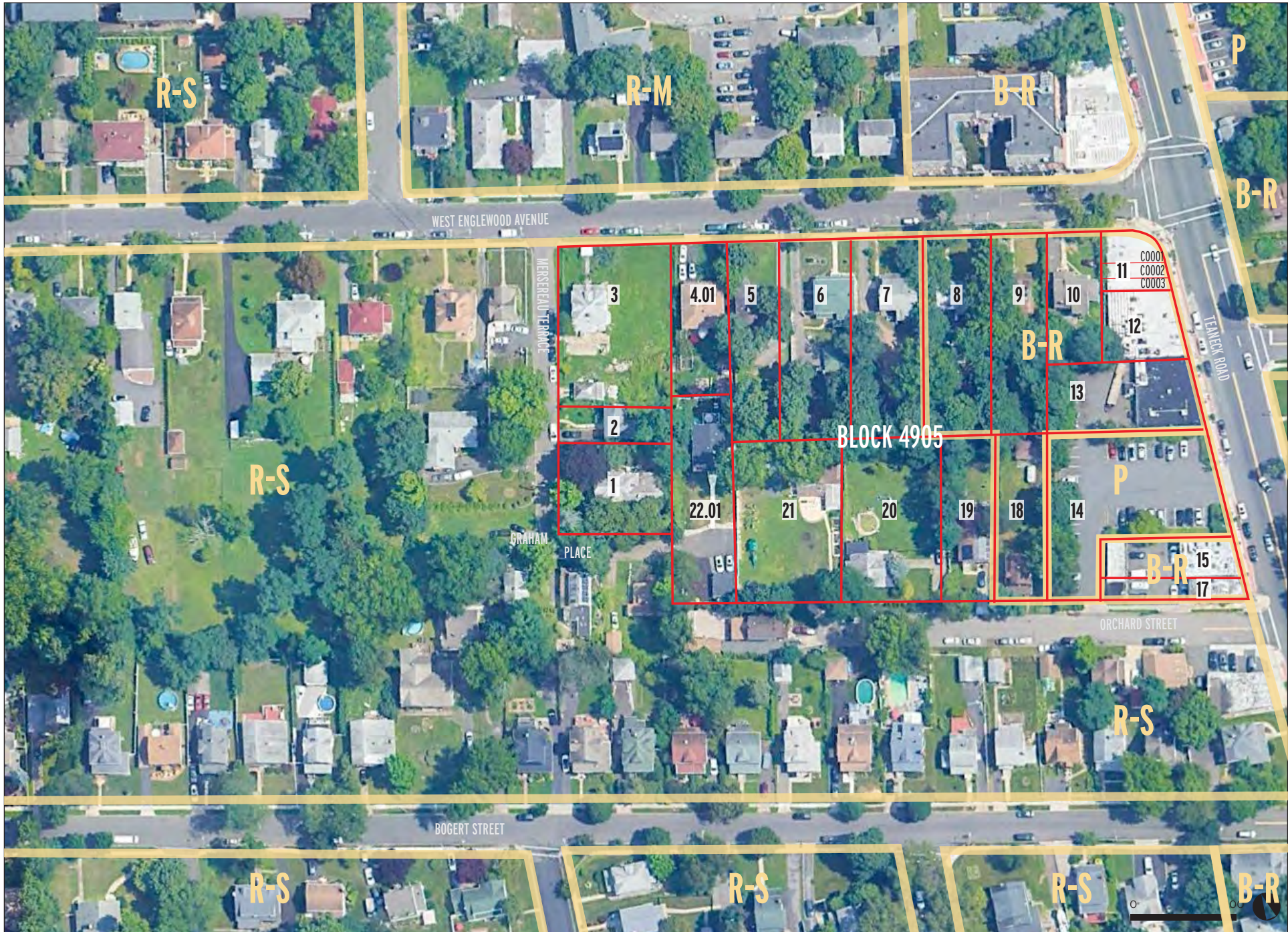

Figure 4: Existing Zoning
 Area in Need of Redevelopment Investigation
 Block 4905, Lots 1 - 22.01 | Township of Teaneck, New Jersey

IV STATUTORY CRITERIA FOR ESTABLISHMENT OF AN AREA IN NEED OF REDEVELOPMENT AND APPLICATION TO THE STUDY AREA

Under the regulations of the LRHL at N.J.S.A. 40A:12A-5, a delineated area may be determined to be in need of redevelopment if, after investigation, notice and hearing as provided in Section 6 of P.L.1992, c.79 (N.J.S.A. 40A:12A-6), the governing body of the municipality by resolution concludes that within the delineated area any of the following conditions is found:

- a. The generality of buildings are substandard, unsafe, unsanitary, dilapidated, or obsolescent, or possess any of such characteristics, or are so lacking in light, air, or space, as to be conducive to unwholesome living or working conditions.
- b. The discontinuance of the use of a building or buildings previously used for commercial, retail, shopping malls or plazas, office parks, manufacturing, or industrial purposes; the abandonment of such building or buildings; significant vacancies of such building or buildings for at least two consecutive years; or the same being allowed to fall into so great a state of disrepair as to be untenable.
- c. Land that is owned by the municipality, the county, a local housing authority, redevelopment agency or redevelopment entity, or unimproved vacant land that has remained so for a period of ten years prior to adoption of the resolution, and that by reason of its location, remoteness, lack of means of access to developed sections or portions of the municipality, or topography, or nature of the soil, is not likely to be developed through the instrumentality of private capital.
- d. Areas with buildings or improvements which, by reason of dilapidation, obsolescence, overcrowding, faulty arrangement or design, lack of ventilation, light and sanitary facilities, excessive land coverage, deleterious land use or obsolete layout, or any combination of these or other factors, are detrimental to the safety, health, morals, or welfare of the community.
- e. A growing lack or total lack of proper utilization of areas caused by the condition of the title, diverse ownership of the real properties therein or other similar conditions which impede land assemblage or discourage the undertaking of improvements, resulting in a stagnant and unproductive condition of land potentially useful and valuable for contributing to and serving the public safety, health and welfare, which condition is presumed to be having a negative social or economic impact or otherwise being detrimental to the safety, health, morals, or welfare of the surrounding area or the community in general.
- f. Areas, in excess of five contiguous acres, whereon buildings or improvements have been destroyed, consumed by fire, demolished or altered by the action of storm, fire, cyclone,

tornado, earthquake or other casualty in such a way that the aggregate assessed value of the areas has been materially depreciated.

- g. In any municipality in which an enterprise zone has been designated pursuant to the "New Jersey Urban Enterprise Zones Act," P.L.1983, c.303 (C.52:27H-60 et seq.) the execution of the actions prescribed in that act for the adoption by the municipality and approval by the New Jersey Urban Enterprise Zone Authority of the zone development plan for the area of the enterprise zone shall be considered sufficient for the determination that the area is in need of redevelopment pursuant to sections 5 and 6 of P.L.1992, c.79 (C.40A:12A-5 and 40A:12A-6) for the purpose of granting tax exemptions within the enterprise zone district pursuant to the provisions of P.L.1991, c.431 (C.40A:20-1 et seq.) or the adoption of a tax abatement and exemption ordinance pursuant to the provisions of P.L.1991, c.441 (C.40A:21-1 et seq.). The municipality shall not utilize any other redevelopment powers within the urban enterprise zone unless the municipal governing body and planning board have also taken the actions and fulfilled the requirements prescribed in P.L.1992, c.79 (C.40A:12A-1 et al.) for determining that the area is in need of redevelopment or an area in need of rehabilitation and the municipal governing body has adopted a redevelopment plan ordinance including the area of the enterprise zone.
- h. The designation of the delineated area is consistent with smart growth planning principles adopted pursuant to law or regulation.

In a study area with multiple parcels, individual properties or blocks that do not meet any of the statutory conditions may still be included within an area in need of redevelopment provided that within the study area as a whole, one or more of the expressed conditions are prevalent. This provision is referred to as "Section 3" and is set forth under N.J.S.A. 40A:12A-3, which states in part:

A redevelopment area may include lands, buildings, or improvements which of themselves are not detrimental to public safety, health or welfare, but the inclusion of which is found necessary, with or without change in this condition, for the effective redevelopment of the area of which they are a part.

The following section considers whether or not the statutory criteria for an "area in need of redevelopment" designation is met in light of existing conditions in the Study Area and other factors.

V STUDY AREA DESCRIPTION AND EVALUATION

This chapter describes the Study Area properties and evaluates whether they meet any of the statutory criteria for a non-condemnation “area in need of redevelopment” designation consistent with the Local Redevelopment and Housing Law. The evaluation is based on site inspections, surveys of land usage, property conditions, occupancy and ownership status, Master Plan designation, Township records, and other relevant information cited below. Application of the area in need of redevelopment criteria is shown in **Figure 5**. Photographs of the Study Area and supporting documentation are provided in the **Appendices**.

A. Individual Property Evaluations

Block 4905, Lot 1 – 61 Graham Place

Lot 1 is a corner lot with 81.97 feet of frontage on the east side of Mersereau Terrace and 106 feet of frontage on the north side of Graham Place. Both streets terminate adjacent to this lot. The property consists of a 1½-story, two-family dwelling built in 1948. There is a one-car garage at the front and a one-car garage at the rear. There are two driveways, with the front driveway leading to an attached one-car garage from Graham Place, and the rear driveway leading to another attached one-car garage, from Mersereau Terrace. Various tires, trash cans, garbage bags, and children’s toys were aligned in a row at the end of the rear driveway. Two vehicles with protective covers are parked in the front driveway. There is cracking in the asphalt of the front driveway. There were several shopping carts and other miscellaneous items located in the front yard and driveway during a site inspection. Several windows on the dwelling are broken and covered with makeshift materials. Many of the windows are also covered by dense shrubs or trees. Property tax cards indicate the building’s interior condition as “estimate” and the overall condition as “typical.”¹

The current property owner was issued a summons on December 11, 2015, with the Teaneck Health Department as the complainant, for failure to maintain the property “by allowing inoperable vehicle.” A complaint was submitted on August 25, 2021 listing “overgrowth, littered, junk vehicles in the driveway, 3 dogs?, property not maintained.” The Teaneck Health Department issued a Notice of Violation on August 26, 2021 for violations of Chapter 19: Garbage and Refuse and Chapter 29A: Property Maintenance Code. Specifically, the violation required removal of junk, garbage, overgrowth, and other matter from the entire property; required repair, removal,

¹ The Teaneck Tax Assessor last conducted inspections in 2014 and made subjective determinations of condition based upon perceived condition. “Typical” generally means that the condition is average and similar to other homes in its neighborhood and value range. “Fair” means that the condition is lesser than that of similar homes in the neighborhood and items such as kitchens and bathrooms may be functional, but in need of upgrades/renovations. “Poor” means that major components are at the end of their useful life and are in need immediate replacement. “Updates” means that major components like kitchens and bathrooms have been recently renovated and the overall appearance is modern and updated. “Estimate” indicates that the property interior was not inspected, and assumptions were made about the condition and room counts, etc. If estimated, generally it was assumed that the basements and attics (if any) were finished and had bathrooms, and that the kitchens and bathrooms were modern (recently renovated).

registration, or cover of parked vehicles in the driveway; and removal of the nuisance or fire hazard in the manner and timeframe provided. An extension was granted until September 20, 2021 to rectify the violations, which were later marked as being abated.

Police records² indicate an incident of "Animal Incident-Domestic" on November 14, 2021 related to an unsecured dog biting children on another property, with the dog residing at 61 Graham Place.

Lot 1 of Block 4905 meets redevelopment criteria "a" and "d" of the LRHL.

Criterion "a": The dwelling is lacking in light and air, considering that several broken windows remain unfixed and are covered with makeshift materials or shrubbery. The grounds are kept in an unsanitary condition, as documented in a Health Department violation and as observed during a site inspection. These conditions are conducive to unwholesome living conditions.

Criterion "d": The building and site improvements are dilapidated, and the building is lacking in light. An unsecured, violent animal was recorded in a police report and the animals were noted in a Health Department complaint. These factors combined are detrimental to the safety, health, morals, and welfare of the community.

Block 4905, Lot 2 – 1347 Mersereau Terrace

This property is located on the east side of Mersereau Terrace with 37 feet of frontage and a depth of 106 feet. The property was built in 1925 and consists of a two-story, single-family residence with an attached, below-grade garage. Lot 2 was the subject of a Zoning Board application in 2021 and 2022 for consolidation with Lot 3 and a site plan proposal with variances for multifamily development. The Board denied the application in July 2022.

A large tree branch was observed to have fallen on the roof near the gutter line during a site inspection. Property tax cards identify the building's interior and overall conditions as "typical." The overall building condition and site improvements appear to be in good condition. There is fencing surrounding the rear yard and along the left side lot line in the front yard. The fencing is wooden, PVC, and chain link, all in fair condition.

There is a police report for an "Unsecured Building" related to an open door on June 20, 2021.

Lot 2 of Block 4905 does not meet any redevelopment criteria of the LRHL.

None: Lot 2 appears to be in good condition, with exception to a tree branch on the roof. However, the building is vacant, such that the branch does not present a threat to human safety at this time. Overall, the property is not detrimental to the safety, health, morals, or welfare of the community, and it does not meet any criteria of the LRHL.

² Only police records that relate to the area in need of redevelopment criteria were notated and considered in this report. Irrelevant records (e.g., domestic disputes or medical records) are not included.

Block 4905, Lot 3 – 54 West Englewood Avenue

This property is a corner lot with 106 feet of frontage on the south side of West Englewood Avenue and 145 feet of frontage on the east side of Mersereau Terrace. The property consists of a 2½-story frame dwelling built in 1909, a one-car garage/shed, and a short driveway from Mersereau Terrace. Property tax cards identify the building's interior condition as "estimate" and the overall condition as "typical." The building is vacant and in poor condition: a portion of the front porch roof has been severely damaged, with exposure of the frame and interior of the roof; and the floor of the front porch has been stripped down to the support beams, without floorboards. The garage/shed in the rear is in very poor condition: there is moss growing all across the roof, and the wall façade and interior are damaged and rotting. The cement driveway is severely damaged with cracking and overgrown vegetation. The driveway is too short to realistically accommodate a vehicle, and the garage is presently unusable due to its poor condition, resulting in no off-street parking. In addition, a large dumpster filled with building materials was observed in front of the garage/shed during a site inspection. The property is surrounded on all sides by chain link and wooden fencing. The trees and landscaping are in poor condition: the lawn is overgrown, and vines have taken over a dead tree in the front yard and are also growing along the fencing.

Lot 3 was the subject of a Zoning Board application in 2021 and 2022 for consolidation with Lot 2 and a site plan proposal with variances for multifamily development. The Board denied the application in July 2022.

A construction permit was issued to replace roofing and floor boards on the porch on November 9, 2018. However, it appears that these improvements were never undertaken.

A neighbor submitted a complaint to the Teaneck Health Department for "overgrown & littered etc." on September 27, 2019. The Health Department issued a Notice of Violation on the same date for violations of Chapter 19: Garbage and Refuse and Chapter 29A: Property Maintenance Code. Specifically, the violations ordered removal of junk, debris, overgrowth, weeds, or other matter from the entire property; maintenance of landscaping, bushes, hedges, etc.; elimination of a mosquito and insect infestation; and an order to remove the nuisance or fire hazard in the manner and timeframe provided. By October 10, 2019, the owner had not abated the violations in the timeframe provided and the Township Department of Public Works (DPW) was instructed to abate the violations. Two violation notices were posted the door of the building on March 10, 2020, and the DPW was again instructed to abate the violations. The following complaint was also submitted on the same date: "appears to be a house that is used for dumping cement, wood, & all kinds of debris. The porch is hanging, as if it will fall down at any time. The garage is loaded with garbage & wood. The house looks abandoned but is being used to store construction debris from other job sites." The Police Department submitted a service request on May 21, 2020 for "high grass." The violation for tall grass was abated on June 18, 2020. A member of the public submitted a service request to the Health Department on August 20, 2020 for repeat violations, stating "vacant house overgrown with mosquitos." A public complaint was submitted via phone on July 26, 2021 for overgrown, abandoned conditions and the presence of mosquitos and various wildlife and rodents.

A Notice of Violation was issued on July 27, 2021 for the same violations noted in September of 2019. The property owner was issued two summonses on August 9, 2021, with the Health Department as the complainant, for failure to remove overgrowth and failure to remove garbage from the property. The owner paid \$54 in lieu of a court appearance for both charges. A member of the public submitted a complain on November 15, 2021 stating that the property was not being maintained and that litter and garbage were observed along with wildlife including groundhogs and deer. A public complaint was again submitted on April 21, 2022 stating that "garbage, etc." was observed throughout the property and rodents were seen. The Health Department issued a Notice of Violation on April 27, 2022 for all of the previous violations, with new violations indicating the need to repair the exterior of the house and garage including roof, gutter, façade, etc. and the need to secure the vacant building to prevent unauthorized access and vandalism.

Lot 3 of Block 4905 meets redevelopment criteria "a" and "d" of the LRHL.

Criterion "a": The dwelling and garage are vacant and in substandard, unsafe, unsanitary, and dilapidated condition, as evidenced by multiple, ongoing Department of Health violations. These conditions render these buildings as conducive to unwholesome living conditions.

Criterion "d": The building and site improvements are seriously dilapidated, and the lack of off-street parking constitutes an obsolete layout. For these reasons, the property is detrimental to the safety, health, morals, and welfare of the community.

Block 4905, Lot 4.01 – 44 West Englewood Avenue

This property has 55 feet of frontage on the south side of West Englewood Avenue and a depth of 140 feet. The property consists of a split-level single-family residence and an attached one-car garage that was built in 1979. The building, driveway, and landscaping are all in good condition. Property tax cards identify the building's interior and overall conditions as "typical."

Lot 4.01 of Block 4905 does not meet any redevelopment criteria of the LRHL.

None: Lot 4.01 appears to be in good condition. Overall, the property is not detrimental to the safety, health, morals, or welfare of the community, and it does not meet any criteria of the LRHL.

Block 4905, Lot 5 – 40 West Englewood Avenue

This property has 50 feet of frontage on the south side of West Englewood Avenue and an average depth of 184.37 feet. The tax records indicate the property has "exempt" status through "Mercy Chu. of God," but this status no longer applies. The property consists of a two-story dwelling built in 1890. There is a finished basement, a covered front porch, a side addition, and a long driveway leading to a rear parking area. Property tax cards identify the overall condition as "updates" and the building's interior condition as "typical." Although the main building has a solid foundation, the side addition is elevated on cinder block supports and is open underneath. The large lawn in the front yard is overgrown. There are building materials, garbage, newspapers, and toys strewn about

the front, side, and rear yards. The mailbox is overflowing with uncollected letters. The property was sold in January 2022 and the building is presently vacant.

The Teaneck Health Department issued a Notice of Violation on December 23, 2021 for violations to Chapter 19: Garbage and Refuse of the Township Ordinance. Specifically, the notice ordered removal of junk and debris, including from the sidewalk and curbside; removal of overgrowth, weeds, junk, debris, or other matter from the entire property, including dead leaves; and a requirement to remove the nuisance or fire hazard in the manner and timeframe provided. The violations had been abated by January 4, 2022.

Lot 5 of Block 4905 meets redevelopment criteria “d” of the LRHL.

Criterion “d”: There was a Health Department violation related to the maintenance of the property grounds, but a similar lack of maintenance and collection of debris and miscellaneous items were observed during a recent site inspection. The site improvements have not improved despite a change in ownership, and they continue to be detrimental to the safety, health, morals, and welfare of the community.

Block 4905, Lot 6 – 32 West Englewood Avenue

This property has 66.25 feet of frontage on the south side of West Englewood Avenue and an average depth of 184.54 feet. The property consists of a two-story single-family dwelling built in 1920. It has a driveway leading to a detached two-car garage and a separate one-car garage in the rear yard. There is a large front yard with landscaping and front walkway. The structures and site improvements are generally in good condition. Property tax cards identify the building’s interior condition as “typical.”

Lot 6 of Block 4905 does not meet any redevelopment criteria of the LRHL.

None: Lot 6 appears to be in good condition. Overall, the property is not detrimental to the safety, health, morals, or welfare of the community, and it does not meet any criteria of the LRHL.

Block 4905, Lot 7 – 26 West Englewood Avenue

This property has 64 feet of frontage on the south side of West Englewood Avenue and an average depth of 184.62 feet. The property consists of a two-story single-family dwelling built in 1912 and a detached one-car garage at the rear. Property tax cards identify asbestos siding and the interior condition as “fair.” Several vehicles were observed parked in the rear yard lawn area during a site inspection, along with various miscellaneous items such as garbage bags, a wheelbarrow, and equipment. The front lawn area and shrubs were observed to be overgrown. A tree in the side yard is covering a substantial portion of the side of the dwelling, blocking light in that area.

The Township Engineer sent a notice of violation to the property owner with instructions to replace portions of the sidewalk abutting the property on November 9, 2020, with a deadline to complete the work by November 30, 2020 or April 30, 2021. Later, another notice of violation of the same

content was sent to a different property owner on October 19, 2021, with a deadline to complete the work by November 26, 2021. The letter warned that Municipal Court action may be pursued if the required action was not completed. A summons was issued on March 10, 2022 for failure to repair the sidewalk.

The Health Department issued a Notice of Violation on October 19, 2018, ordering a removal of junk, debris, overgrowth, weeds, or other matter from the entire property and to maintain landscaping, bushes, hedges, etc. on this and adjacent properties. The violations are noted as abated on October 31, 2018. A member of the public later submitted a Service Request on December 7, 2018 for leaves, litter, debris, and overgrowth. The Health Department issued a Notice of Violation on December 7, 2018, ordering the owner to remove junk, debris, overgrowth, weeds, or other matter from the entire property, to maintain landscaping, bushes, hedges, and trim back the hedges obstructing some of the sidewalk, and to remove dead leaves, litter, and debris including from the curbside area. The violations are indicated as abated on December 18, 2018.

A neighbor contacted the Township with a complaint concerning a lack of "responsibility and upkeep of the lawn, trees, sidewalks, and front of property" at 22, 24 & 26 West Englewood Avenue. The Teaneck Health Department completed a Service Request Form on September 29, 2020 and a Problem Report Form on October 2, 2020 related to the complaint. The Health Department issued a Notice of Violation of Chapter 19: Garbage and Refuse and Chapter 29A: Property Maintenance Code of the Township Ordinance on October 13, 2020 for 20, 22 & 26 West Englewood Avenue. Specifically, the notice orders removal of junk, debris, overgrowth, weeds, dead leaves, or other matter from the entire property and to maintain and trim bushes/hedges and other landscaping for all three properties. An extension request was granted until April 2021 due to cold weather. The violations were indicated as abated. A year later on April 26, 2022, a Code Enforcement officer for the Township submitted a complaint for "garbage, etc." throughout the properties and "rodents seen." The Health Department issued a Notice of Violation on the same dates for failure to remove junk, debris, overgrowth, weeds, or other matter from the entire property; an order to maintain landscaping, bushes, hedges, etc.; for exterior evidence of an infestation and an order to treat the property for rodents; and an order to remove the nuisance or fire hazard in the manner and timeframe required. It is not noted if these violations have been abated.

Separately, a resident at the premises submitted a Service Request to the Health Department for sewage backup in the basement on June 29, 2021. The Health Department contacted the owner via email the same day, ordering cleanup, sanitization, and inspection of the basement. The Health Department issued two summonses on July 8, 2021 for failure to clean and disinfect the basement after a sewer backup and for failure to maintain plumbing facilities in good repair. The Township conducted an inspection on July 9, 2021 and noted violations including disrepair of wooden stairs leading to the basement, disrepair of several doors and doorknobs, peeling paint in the kitchen and living requiring scraping and repainting, a rodent infestation in need of extermination, sealing of holes and opening in the house to avoid entry of rodents including behind floor radiators and baseboards, the need to fix ceiling lights in the bedrooms, living room, and first floor bathroom, and the disrepair of the main entrance door. The Department ordered that all violations be abated

before August 2, 2021 and receipt of a Certificate of Health by passing an inspection. Summonses were issued on September 22, 2021 for failure to maintain the dwelling free from vermin, insects, pests, and rodents. and a failure to obtain a Certificate of Health.

There is a police report for a "Theft" of a backpack blower from a trailer in the rear yard, on November 8, 2018.

There were two tax sales that occurred on January 13, 2022 for a total of \$30,993.02, but these were paid as of July 19, 2022. Tax collection records indicate a Q2 2022 tax balance of \$3.12.

Lot 7 of Block 4905 meets redevelopment criteria "a" and "d" of the LRHL.

Criterion "a": The dwelling is substandard, unsafe, unsanitary, and dilapidated, as documented by numerous Health Department violations. These conditions are conducive to unwholesome living conditions.

Criterion "d": The dwelling and site improvements are dilapidated and have been found to lack sanitary facilities to contain trash and debris, as documented by numerous violations from the Health Department and the Township Engineer. These conditions are detrimental to the safety, health, morals, and welfare of the community.

Block 4905, Lot 8 – 22 West Englewood Avenue

This property has 60 feet of frontage on the south side of West Englewood Avenue and an average depth of 184.84 feet. The property consists of a 2½-story, two-family dwelling built in 1919, with a covered front porch, a basement level, and a three-car detached garage along the rear lot line. Property tax cards identify the building's interior condition as "typical" and the overall condition as "fair." The exterior of the building is in poor condition: roof shingles are missing, materials on the roof eaves have come off or are hanging, the vinyl siding of a dormer window is damaged and slanting and the windows' screens are torn, a parapet surrounding the front porch is slanting, the porch columns are in need of painting, and the brick front steps are in need of repointing. The rear garage is in poor condition as well: siding along the eaves has come off, there is moss growing on the roof and cement siding, and the garage doors need repainting.

There is a gravel driveway on the east side of the dwelling that leads to a rear parking area and a wide paver walkway on the west side of the dwelling. The sidewalk in front of the driveway is severely damaged. In the front yard, the lawn was overgrown and eight trash/recycling containers, garbage, and furniture were strewn along the paver driveway. Trash was also observed in the west side yard. Tree branches located along the side yards are hanging over and touching the roof. In the rear yard, there is a large collection of miscellaneous items, including towing trailers, car parts, tarps, building materials, discarded furniture, and other large items, many of which block access to the garage. There is poor drainage resulting in mud and puddles in the gravel driveway and parking area. A curb that appears to have once delineated the driveway leading to the garages is covered in dirt and serves no purpose, as vehicles were observed parked in the rear yard rather than in the

garage. The concrete steps leading to a rear patio are severely broken and are surrounded by overgrown vegetation. There are miscellaneous items including a damaged wooden box, a broken PVC storage container, broken furniture, and trash at the rear of the building and on the patio.

The Township Engineer sent a Notice of Violation to the property owner with instructions to replace portions of the sidewalk abutting the property on November 9, 2020, with a deadline to complete the work by November 30, 2020 or April 30, 2021. Later, another Notice of Violation of the same content was sent to a different property owner on October 19, 2021, with a deadline to complete the work by November 26, 2021. The letter warned that Municipal Court action may be pursued if the required action was not completed. As observed during a site inspection, the sidewalk remains broken in front of the gravel driveway.

A member of the public submitted a Service Request on October 18, 2018 for "overgrown bushes/garbage all over property" for this and an adjacent property. The Health Department issued a Notice of Violation on October 19, 2018, ordering a removal of junk, debris, overgrowth, weeds, or other matter from the entire property and to maintain landscaping, bushes, hedges, etc. on this and adjacent properties. The violations are noted as abated on October 31, 2018. A member of the public later submitted a Service Request on December 7, 2018 for leaves, litter, debris, and overgrowth. The Health Department issued a Notice of Violation on December 7, 2018, ordering the owner to remove junk, debris, overgrowth, weeds, or other matter from the entire property, to maintain landscaping, bushes, hedges, and trim back the hedges obstructing some of the sidewalk, and to remove dead leaves, litter, and debris including from the curbside area. The violations are indicated as abated on December 18, 2018. A neighbor contacted the Township with a complaint concerning a lack of "responsibility and upkeep of the lawn, trees, sidewalks, and front of property" at 22, 24 & 26 West Englewood Avenue. The Teaneck Health Department completed a Service Request Form on September 29, 2020 and a Problem Report Form on October 2, 2020. The Health Department issued a Notice of Violation of Chapter 19: Garbage and Refuse and Chapter 29A: Property Maintenance Code of the Township Ordinance on October 13, 2020 for 20, 22 & 26 West Englewood Avenue. Specifically, the notice orders removal of junk, debris, overgrowth, weeds, dead leaves, or other matter from the entire property and to maintain and trim bushes/hedges and other landscaping for all three properties. An extension request was granted to abate the violations until April 2021 due to cold weather. The violations were indicated as abated.

This property has a lien for two tax sales that occurred on January 13, 2022 for a total of \$51,150. The lien was current as of July 19, 2022.

The two-family dwelling is permitted in the B-R District in which it is located.

Lot 8 of Block 4905 meets redevelopment criteria "a," "d," and "e" of the LRHL.

Criterion "a": The dwelling and garage are substandard, unsafe, and dilapidated, as observed during site observations. These conditions are conducive to unwholesome living conditions.

Criterion “d”: The dwelling, garage, and site improvements are dilapidated and have been found to lack sanitary facilities to contain trash and debris, as documented by numerous violations from the Health Department and the Township Engineer. Further, the parking arrangement is faulty, considering that the garage is not actively used, and vehicles are instead parked in an area of the rear yard which was once distinguished from the driveway by a curb. These factors combined are detrimental to the safety, health, morals, and welfare of the community.

Criterion “e”: The recent and substantial tax lien exceeding \$50,000 discourages the undertaking of improvements that are sorely needed at this property, leading to continued stagnation of the dilapidated site and building conditions. These conditions will continue to have a negative social impact, as they are detrimental to the safety, health, morals, and welfare of the occupants and the surrounding community.

Block 4905, Lot 9 – 20 West Englewood Avenue

This property has 50 feet of frontage on the south side of West Englewood Avenue and a depth of 185 feet. The property consists of a 2½-story, two-family dwelling built in 1930. There is an asphalt driveway leading to a rear parking area a detached three-car garage located along the rear property line. The exterior of the building is in fair condition with the need for some repairs: the shingles on the roof are damaged in some places, the gutters are partially detached, and the stonework on the front entry steps is severely damaged and in need of repair. A dead squirrel was observed on the roof during a site inspection. The garage in the rear yard is in fair condition, as there is some moss covering the roof and there are minor indentations on the garage doors. The asphalt driveway is deteriorated, showing areas of dirt where the paving has worn away. There are ungroomed shrubs along the front property line. In the rear yard, there is a raised porch with deck furniture that all appears to be in good condition. The rear yard is entirely gravel and dirt, with space to park four vehicles in addition to the parking available in the three-car garage. There is a dump truck and a haphazard collection of miscellaneous items at the southeast corner of the property, including trash cans, broken sections of fencing, building materials, a bicycle, a ladder, etc. These items are viewable from the parking lot on Lot 13. The chain link fencing along this shared property line with Lot 13 is badly damaged. Property tax cards identify the building’s interior and overall conditions as “typical,” but it should be noted that these records were created in 2014.

A member of the public reported property maintenance issues related to this and adjacent properties on April 18, 2018. The Teaneck Health Department issued a Notice of Violation on May 4, 2018 for violations of Chapter 19: Garbage and Refuse and Chapter 29A: Property Maintenance Code of the Township Ordinance for an exterior that is blighted, deteriorated, and/or inadequately maintained, and an order to repair/replace damaged fence located on the east side of the property and to remove overgrowth, weeds, junk, debris or other matter from the entire property. The violations were recorded as abated on May 16, 2018. Later, a member of the public submitted a Service Request on October 18, 2018 for “overgrown bushes/garbage all over property” for this and an adjacent property. The Health Department issued a Notice of Violation on October 19, 2018, ordering a removal of junk, debris, overgrowth, weeds, or other matter from the entire property

and to maintain landscaping, bushes, hedges, etc. on this and adjacent properties. The violations are noted as abated on October 31, 2018. A member of the public later submitted a Service Request on December 7, 2018 for leaves, litter, debris, and overgrowth on this and adjacent properties. The Health Department issued a Notice of Violation on December 7, 2018, ordering the owner to remove junk, debris, overgrowth, weeds, or other matter from the entire property, to maintain landscaping, bushes, hedges, and trim back the hedges obstructing some of the sidewalk, and to remove dead leaves, litter, and debris including from the curbside area. The violations are indicated as abated on December 18, 2018. A neighbor contacted the Township with a complaint concerning a lack of “responsibility and upkeep of the lawn, trees, sidewalks, and front of property” at 22, 24 & 26 West Englewood Avenue. The Teaneck Health Department completed a Service Request Form on September 29, 2020 and a Problem Report Form on October 2, 2020. The Health Department issued a Notice of Violation of Chapter 19: Garbage and Refuse and Chapter 29A: Property Maintenance Code of the Township Ordinance on October 13, 2020 for 20, 22 & 26 West Englewood Avenue. Specifically, the notice orders removal of junk, debris, overgrowth, weeds, dead leaves, or other matter from the entire property and to maintain and trim bushes/hedges and other landscaping for all three properties. An extension request was granted to abate the violations until April 2021 due to cold weather. The violations were indicated as abated.

There were minor property-related police reports in the past five years, including for “Impounded or Abandoned Vehicle” on August 16, 2017. However, these auto-related violations do not appear to relate to the layout or conditions of the property.

There were two tax sales that occurred on January 13, 2022 for a total of \$48,250, but these were paid as of July 19, 2022.

The two-family dwelling is permitted in the B-R District in which it is located.

Lot 9 of Block 4905 meets redevelopment criteria “a” and “d” of the LRHL.

Criterion “a”: The dwelling is substandard, unsanitary, unsafe, and dilapidated, as observed during site observations. These conditions are conducive to unwholesome living conditions.

Criterion “d”: The building and site improvements are dilapidated, as documented by recent site observations and numerous Health Department violations over the past several years. The site also lacks sanitary facilities, i.e., proper trash storage and removal, for the large collection of miscellaneous items and garbage in the rear yard. These factors combined are detrimental to the safety, health, morals, and welfare of the community.

Block 4905, Lot 10 – 18 West Englewood Avenue

This property has 55 feet of frontage on the south side of West Englewood Avenue and a depth of 120 feet. The property consists of a 2½-story, one-family dwelling built in 1936, with a basement and a detached two-car garage in the rear yard. There is an asphalt driveway leading to the garage and a rear parking area. Property tax cards identify the building’s interior and overall conditions as

“updates.” Site improvements need repair, including the deteriorated asphalt driveway, and the concrete sidewalk and walkway to the front entry have extensive cracking.

A construction permit was issued to remove an underground storage tank (UST) at the rear of the property on October 21, 2020.

The single-family dwelling is permitted in the B-R District in which it is located.

Lot 10 of Block 4905 does not meet any redevelopment criteria of the LRHL.

None: Lot 10 appears to be in good condition. Overall, the property is not detrimental to the safety, health, morals, or welfare of the community, and it does not meet any criteria of the LRHL.

Block 4905, Lot 11 – 1360-1364 Teaneck Road

Lot 11 is an irregular corner lot with curved property line on the southwest corner of West Englewood Avenue and Teaneck Road. It has a depth of 55.23 feet from West Englewood Avenue and a depth of 63.64 feet from Teaneck Road. Lot 11 consists of a one-story commercial building split into three commercial condominium units known as 11-C0001, 11-C0002, and 11-C0003. The building has a brick façade and concrete signs indicating a build year of 1925 and the name “Nelrose Building.” A faded red awning with white lettering is affixed to one of the commercial storefronts, the design of which matches the awnings on Lot 12 to the south. There is a vent stack affixed to the north side of the building for commercial kitchen use. The property is completely impervious. At the rear of the building, there is a concrete walkway, a narrow ditch, and a collection of rubble along the fence line. A rusted metal drum is also stored behind this commercial space. The building continues onto Lot 12 to the south.

There is a vacant commercial space located at the intersection of Teaneck Road and West Englewood Avenue. It should be noted that one of the addresses marked on the storefront and tax map, 1364 Teaneck Road, does not match property tax records that show 1360 Teaneck Road for the corner commercial space. The large front windows are papered. The commercial space was most recently occupied by two fast-casual restaurants, Krispy Krunchy Chicken and Lahore Biryani & Grill, which have since closed. The last Yelp reviews for each business are dated in early September 2020. Police records indicate that the Krispy Krunchy Chicken tenant was evicted in August or September of 2021. A construction permit was issued for alterations to remove block stairs in the basement on February 26, 2018.

A member of the public contacted the Township on October 26, 2020 regarding graffiti on the storefront of the property (listed as 1364 Teaneck Road but pictures showing the corner commercial space). The Teaneck Health Department issued a Notice of Violation to the property owner for an exterior that was “blighted, deteriorated, and/or inadequately maintained” in violation of Chapter 29A: Property Maintenance Code, due to graffiti on the storefront, and an order to remove it. A subsequent Final Notice of Violation was issued on March 31, 2021. An extension to

correct the violation was granted until April 23, 2021. The violation was indicated as abated on April 15, 2021.

Property-related police records from the past five years include: Malicious Mischief - broken window (7/29/17), Request for Police Documentation - locks changed due to rent unpaid at Hit City Seafood (11/7/17), Burglary Forced Entry - broken window (11/19/17), Police Information - contractor reneged on work (12/21/19), Landlord/Tenant Dispute - unpaid rent and interior damage (9/4/21), Criminal Mischief, Theft - theft of appliances and interior damage amounting to \$8,610 in evicted KKC space (2/5/22).

The interior commercial space is occupied by an active beauty supplies retailer, Ebony Beauty Supplies. It should be noted that the address as marked on the storefront and tax map, 1360 Teaneck Road, does not match property tax records that show 1364 Teaneck Road for the interior space. An air conditioning unit is located above the store windows, above which some water damage was observed on ceiling tiles and below which water was dripping along the front of the building, likely causing some bulging of the façade material below. There are no Health Department violations or police records associated with this space.

Lot 11 of Block 4905 meets redevelopment criterion “d” of the LRHL.

Criterion “d”: One of the commercial spaces on Lot 11 is vacant and has experienced ongoing issues related to interior damage, forced entry, and repeated business failure. The Health Department also documented exterior neglect (graffiti). Further, the building has excessive land coverage and does not have modern stormwater management facilities to handle runoff. These factors combined render Lot 11 as detrimental to the safety, health, morals, and welfare of the community.

Block 4905, Lot 12 – 1354-1358 Teaneck Road

This property has 66.11 feet of frontage on the west side of Teaneck Road and a depth of 73.9 feet. The property consists of four commercial spaces in a one-story commercial building that extends onto Lot 11. Together, the four commercial spaces comprise 5,808 square feet, according to property tax cards. The building has a brick façade and concrete signs indicating a build year of 1925 and the name “Nelrose Building.” Red awnings with white lettering, two of which are faded, are located across the front of the building, which matches the awnings of adjacent businesses to the north. Although property tax cards do not list the condition of the property, the building appears to be in good condition. The property is completely impervious. At the rear of the building, there is a concrete walkway and a narrow ditch.

The northern commercial space has approximately 19 feet of frontage and is presently vacant. An awning indicates the former business as Ana S Beauty Salon, which Google lists as permanently closed. The latest Yelp reviews for this business are dated in 2016, the latest Facebook page posts are from 2018, and the latest Google review is from “a year ago.” The Township does not have records related to this business, and the New Jersey State Board of Cosmetology and Hairstyling

does not have record of a hairstyling business at this location or under the above name, based on a July 13, 2022 phone conversation. There are no real estate signs indicating the commercial space is for lease or for sale, and the New Jersey Multiple Listing Service, Inc. (NJMLS) does have a listing for the property. No construction permits have been issued to prepare the space for reoccupation.

The next commercial space has a frontage of approximately 25 feet and is presently vacant. Police reports from December 2018 indicate that this space, which was formerly occupied by H&R Discount Liquors, was vacant at that time. The awning still lists the former business name, and small signs are still posted in the windows.

The next commercial space is occupied by Kimmy's Beauty Spa Nails, and the southern commercial space is occupied by Reggae Kitchen. These two commercial spaces were previously considered one commercial space at the time of the last inspection, with a combined frontage of 22 feet. However, the space has since been divided into two smaller spaces.

There have been several property-related police reports for 1354-1358 Teaneck Road, including: Disturbance/Noise Complaint, Theft (6/1/18), Unsecured Building - vacant space (12/29/18), Criminal Mischief - Reggae Kitchen broken window and door (12/19/18), Criminal Mischief, Observ Rpt-General, knocked-over trash can & newspaper dispenser (7/4/20), Disturbance/Noise Complaint (3/10/22).

There was a Q1 2022 tax balance of \$5,421.83 and a Q2 tax balance of \$5,438, for a total delinquent tax balance of \$10,859.83. An additional outstanding Q3 2022 tax balance of \$5,453.74 would be considered delinquent if still unpaid after August 10, 2022, which occurs after the date of this report.

Lot 12 of Block 4905 meets redevelopment criteria "b," "d," and "e" of the LRHL.

Criterion "b": Over 1/3 of the commercial floor area has been vacant since at least December 2018 (H&R Discount Liquors), and 2/3 of the commercial floor area (H&R and Ana S Beauty Salon) are presently vacant. These constitute significant vacancies of the commercial building.

Criterion "d": One of the three commercial spaces has been vacant for close to four years, and it does not appear to have been prepared for re-occupancy or listed for lease. This business's obsolete and neglected condition has resulted in issues commonly associated with property neglect, including an unsecured building, theft, and criminal mischief at this and other commercial spaces on the same property, as documented in police reports. The property also has excessive coverage and does not have modern stormwater management facilities to manage runoff. These factors combined are detrimental to the safety, health, morals, and welfare of the community.

Criterion "e": This property has an outstanding delinquent tax balance of \$10,859.83 from the first half of the year. This tax balance discourages the undertaking of improvements that are needed to re-lease the vacant commercial spaces, leading to continued economic stagnation, neglect, and criminal activities associated with neglect (unsecured building, theft, criminal mischief). These

conditions will continue to have a negative social and economic impact, as they are detrimental to the safety, health, morals, and welfare of the surrounding community.

Block 4905, Lot 13 – 1348-1352 Teaneck Road

This property has 66.63 feet of frontage on the west side of Teaneck Road and an average depth of 137.08 feet. The property consists of a one-story commercial retail building with two commercial spaces totaling 4,462 square feet, and a parking lot at the rear. The northern space is occupied by H&S Discount Liquors, which moved locations from a neighboring building to the north. The southern space is occupied by a Blimpie fast food restaurant and a Surf City Squeeze juice business. There is a retractable awning above the liquor store and a channel-letters sign and banner sign on the Blimpie façade. The windows of the liquor store are covered in advertising for alcoholic beverages.

The western half of the property consists of an unstriped parking lot with areas of surface damage. Vehicles were observed parked at various angles during a site inspection, and in one case a vehicle was blocking another vehicle. Since the building accounts for the entire width of the property, vehicles must traverse Lot 14 in order to access the rear parking lot from either Teaneck Road or Orchard Street. A chain link fence along the rear property line is badly bent and leaning in all locations. Trash has accumulated on Lot 13 along the fence line. An unenclosed dumpster is located behind the building.

A member of the public requested a service request for “garbage in the back of stores” to the Teaneck Health Department on April 11, 2018. The Health Department issued a Notice of Violation on the same date for violations to Chapter 19: Garbage and Refuse of the Township Ordinance, noting uncovered debris and/or trash receptacle and an order to remove the debris, garbage, litter, and other matter from the rear parking lot on a regular basis. These violations were abated on April 23, 2018. Separately, a member of the public submitted a complaint on April 18, 2018 for various violations, including the need to repaint, a rusting vent pipe “about to break and collapse at Rear,” the need for repaving of the parking lot as well as striping and directional arrows, debris at the rear of the building, and reporting of a broken fence at the rear with missing parts. The Health Department issued a Notice of Violation on May 4, 2018 for an exterior which is “blighted, deteriorated, and/or inadequately maintained,” with an order to scrape and repaint the rusted vent pipe and exterior of the yellow building, and to remove garbage, junk, and debris from the entire property, including the parking lot. The violations were listed as abated on October 1, 2018.

Construction permits were issued to establish a Blimpie fast food restaurant, to install two HVAC units on the roof, and to install a new business sign on December 10, 2019; and to install a commercial backflow preventer on July 29, 2020. A Certificate of Occupancy was issued on the same date. Property tax cards do not list the condition of the property.

There have been several property-related police reports for 1348-1352 Teaneck Road, including: Alarm-Burglar, Shoplifting – at the liquor store (7/20/18, 3/3/21), Attempted/Burglary – at the liquor store (7/28/18), Investigation Follow-up (8/2/18), Illegal Dumping – generator and garbage

(11/30/19), Shoplifting - at the liquor store (12/10/19), MV Crash - in the parking lot (9/14/19, 6/1/22); Police information, intoxicated customer (3/18/22).

Lot 13 of Block 4905 meets redevelopment criterion "d" of the LRHL.

Criterion "d": The arrangement of parking spaces is unclear because the rear lot is unstriped, which has resulted in two motor vehicle crashes occurring in the parking lot. Further, the parking lot depends on Lot 14 for access and is unclear if there is a permanent access easement. Therefore, the arrangement of and access to the parking lot is faulty. In addition, the building and site improvements have been documented as dilapidated and poorly maintained, based on multiple Health Department violations and a police report for illegal dumping. Although there have been renovations to the building since the violations were recorded, the rear parking lot and fence are still dilapidated and unkempt. Police reports also indicate issues with burglaries and shoplifting at the liquor store business. These factors combined are detrimental to the safety, health, morals, and welfare of the community.

Block 4905, Lot 14 – 1344 Teaneck Road

This property is an L-shaped lot located that wraps around Lots 15 and 17, with 107.22 feet of frontage on the west side of Teaneck Road and 49.3 feet of frontage on the north side of Orchard Street. The property consists of a surface parking lot with ±38 striped parking spaces and access from both Teaneck Road and Orchard Street. Landscaping buffers the parking lot from Teaneck Road, and there is a bench in front of the property along the sidewalk. The pavement has minor cracking throughout, but the parking lot and landscaping are in good condition overall. Property tax cards do not list the condition of the property.

The lot is owned by the Township and there are various signs indicating parking regulations. A sign at the Teaneck Road entrance states "Free Shopper Parking." Some spaces are marked as "Reserved Parking, Merchant Permit Only 8AM-6PM," whereas others are marked with two signs: "Parking By Twsp. Permit Only M-F 8AM to 5PM Except Holidays" and "4 Hour Parking 8AM-6PM Except Sun & Holidays." A sign also indicates that truck, trailer, bus, and recreational vehicle parking are prohibited from 8PM to 6AM. A speed limit of 10 miles per hour is posted.

Lot 14 of Block 4905 does not meet any redevelopment criteria of the LRHL.

None: Lot 14 appears to be in good condition. Overall, the property is not detrimental to the safety, health, morals, or welfare of the community, and it does not meet any criteria of the LRHL.

Block 4905, Lot 15 – 1338-1340 Teaneck Road

This property has 39.84 feet of frontage on the west side of Teaneck Road. The property consists of the northern two-thirds of a two-story commercial building, four garage spaces in a six-car parking garage at the rear of the property, and an unstriped parking lot in between the two structures. The ground floor commercial spaces are occupied by Leasco Automotive Sales & Leasing, Inc. and Unique Styles Beauty Salon. On the second-floor office spaces, there are signs for

Build Insurance Brokers and Access Computer Systems. The building appears to be in relatively good condition, despite an unattractive refinishing and painting of a portion of the rear façade. Property tax cards do not list the condition of the property. Vehicles accessing the garage and parking lot must traverse Lot 17 from the curb cut on Orchard Street. Leasco vehicle inventory was observed to be parking in the lot, and some vehicles were blocking other vehicles.

There was one police report for “Theft” from a Leasco vehicle on June 20, 2022.

Lot 15 of Block 4905 meets redevelopment criterion “d” of the LRHL.

Criterion “d”: Although the building is well-utilized, the parking is insufficient to support the office and retail spaces. The lack of striping and overcrowding in the parking lot has also resulted in obstructed egress for several vehicles. The division of a single building, parking garage, and parking lot into two separate tax lots with separate owners, when tax Lots 15 and 17 effectively function as one property, prevents the undertaking of improvements to correct the parking issues. The faulty arrangement and obsolete layout of the property is detrimental to the safety and welfare of the community.

Block 4905, Lot 17 – 1334 Teaneck Road

This property is a corner lot with 20 feet of frontage on the west side of Teaneck Road and 132.62 feet of frontage on the north side of Orchard Street. The property consists of the southern one-third of a two-story commercial building, two garage spaces in a six-car parking garage at the rear of the property, an unstriped parking lot between the two structures, and ingress/egress driveway from Orchard Street. The ground floor space is occupied by Elsa’s Beauty Salon II and an apartment occupies the second floor. Property tax cards do not list the condition of the property, but the building appears to be in good condition based on site observations. Two parked vehicles were observed in the driveway entrance, thereby obstructing ingress or egress of other vehicles. No spaces are marked for Americans with Disabilities Act (ADA) accessibility.

There is one police report for a “Disturbance/Noise Complaint” at Elsa’s Beauty Salon on December 30, 2018.

Lot 17 of Block 4905 meets redevelopment criterion “d” of the LRHL.

Criterion “d”: Although the building is well-utilized, the parking is insufficient to support the office and retail spaces. The lack of striping and overcrowding in the parking lot has also resulted in obstructed egress for several vehicles. The division of a single building, parking garage, and parking lot into two separate tax lots with separate owners, when tax Lots 15 and 17 effectively function as one property, prevents the undertaking of improvements to correct the parking issues. The faulty arrangement and obsolete layout of the property is detrimental to the safety and welfare of the community.

Block 4905, Lot 18 – 23 Orchard Street

This property has 49.3 feet of frontage on the north side of Orchard Street and an average depth of 157.68 feet. The property consists of a 2½-story single-family residence built in 1911 and a three-car garage and small shed at the rear. There is a one-car driveway that is a mix of lawn and gravel. There are no sidewalks in front of the property. Property tax cards identify asbestos siding, and the building's interior and overall condition as "typical."

A member of the public reported property maintenance issues related to this and adjacent properties on April 18, 2018. It is noted that the wooden fence on the subject property is in disrepair. The Teaneck Health Department issued a Notice of Violation on May 4, 2018 for violation of Chapter 29A: Property Maintenance Code for an exterior that is blighted, deteriorated, and/or inadequately maintained, with an order to replace the damaged wooden fence on the east side of the property. The violation was noted as abated on May 16, 2018.

Construction permits were issued for removal of an underground storage tank (UST) on August 27, 2021, for chimney liner on February 25, 2022, and for a replacement boiler on March 11, 2022.

The single-family dwelling is permitted in the B-R District in which it is located

Lot 18 of Block 4905 does not meet any redevelopment criterion of the LRHL.

None: Although the driveway needs repaving and the exterior siding contained asbestos at the time of the last 2014 inspection, the building and other site improvements appear to be in generally acceptable condition, and the asbestos siding does not infringe upon the health of interior occupants. A property maintenance violation from 2018 was abated with no repeat or ongoing violations. The owner received approval to complete improvements to the heating systems and to remove a UST, showing efforts at maintenance of the site. Overall, the property is not detrimental to the safety, health, morals, or welfare of the community, and it does not meet any criteria of the LRHL.

Block 4905, Lot 19 – 27 Orchard Street

This property has 49.3 feet of frontage on the north side of Orchard Street and an average depth of 156.26 feet. The property consists of a bi-level, single-family residence built in 1981, with an attached one-car garage and driveway. A vehicle was observed parking in the driveway and a second vehicle was observed parked on the lawn. Property tax cards identify the building's interior and overall conditions as "typical." The building, driveway, and landscaping appear in good condition. There is no sidewalk in front of the property.

Lot 19 of Block 4905 does not meet any redevelopment criterion of the LRHL.

None: The building and site improvements appear to be in good condition. The property is not detrimental to the safety, health, morals, or welfare of the community, and it does not meet any criteria of the LRHL.

Block 4905, Lot 20 – 35 Orchard Street

This property has 98.6 feet on the north side of Orchard Street and an average depth of 153.13 feet. The property consists of a 1½-story single-family residence built in 1910, a detached one-car garage, and a paver driveway and walkway to the house. The residence faces east toward the driveway, which are both situated toward the front of the property, leaving a large, open rear yard. There is landscaping shrubs along the driveway and the front property line. Property tax cards identify the building's interior and overall conditions as "updates." There is no sidewalk in front of the property.

This property has a lien for two tax sales that occurred on January 13, 2022 for a total of \$47,248.74. The lien was current as of July 19, 2022.

Lot 20 of Block 4905 does not meet any redevelopment criteria of the LRHL.

None: The building and site improvements appear to be in good condition. Although there is a substantial tax lien exceeding \$45,000 associated with this property, the lien has not contributed to stagnant or unproductive conditions or resulted in negative social or economic impacts. Therefore, the property is not detrimental to the safety, health, morals, or welfare of the community, and it does not meet any criteria of the LRHL.

Block 4905, Lot 21 – 43 Orchard Street

This property has a lot width of 99.3 feet, of which approximately half has street frontage on the north side of Orchard Street, and an average lot depth of 151.27. The property consists of a one-story single-family residence built in 1910. There is no driveway on the site; rather, one vehicle was observed parked on a gravel patch in the public right-of-way, located off the terminus of Orchard Street. The front property line is lined with shrubs along a gated chain link and wire fence, and there is solid fencing surrounding the property on the remaining lot lines. The dwelling is set back considerably from the street, at the northeast corner of the lot, leaving a large front and west side yard. The front yard consists of a walkway and a large patio, and the side yard consists of playground equipment and structured garden beds. Property tax cards identify the building's interior condition as "typical" and the overall condition as "fair."

A construction permit was issued on September 12, 2019 for removal of an underground storage tank (UST) in the backyard.

Lot 21 of Block 4905 does not meet any redevelopment criterion of the LRHL.

None: The property does not provide on-site parking, considering that the one parking space appears to be in the public right-of-way. However, the building and site improvements were observed to be in good condition, despite a property tax cards indication of "fair" overall conditions from 2014. The owner has also made efforts to remove the UST on the site, thereby improving the property's condition. Overall, the property is not detrimental to the safety, health, morals, or welfare of the community, and it does not meet any criteria of the LRHL.

Block 4905, Lot 22.01 – 1335 Graham Place

This property is located at the terminus of Graham Place, which has a width of 30 feet. However, the lot dimensions are 55 feet by an average of 193.41 feet. The property consists of a two-story, single-family residence at the north end and a detached two-car garage at the south end. The driveway extends straight off of the terminus of Graham Place. The yard around the dwelling consists of lawn area and a patio. There is a stretch of river stones between the lawn and the driveway. The yard adjacent to the west of the garage is covered in mulch, on top of which is a fire pit with lawn chairs. The property is surrounded on all sides by white PVC fencing. A trash container is located near the driveway entrance and is partially shielded by lattice fencing. Property tax cards identify the building was built in 2020, and its interior and overall condition are listed as “typical.”

An animal trap was observed in the mulched yard. There was an overabundance of small animals such as squirrels observed in the neighborhood during a site inspection.

A construction permit was issued to rebuild the first floor, add a new second floor addition, add new front and rear porches, and install two A/C units on August 16, 2019. The permit was subsequently updated for a change of contractor for electrical and fire, for adding electric fixtures and garage sub-panels, updating two HVAC units, and for a radon system. The property was issued a penalty for occupying the building prior to receiving a certificate of occupancy on February 1, 2022.

There are two police reports for 1335 Graham Place prior to the construction of the new dwelling: “Burglary/Unlawful Entry” of the former vacant house on October 16, 2017 and “Criminal Trespass” related to people found in the house while under construction on December 31, 2019.

Lot 22.01 of Block 4905 does not meet any redevelopment criterion of the LRHL.

None: The driveway access is unusual off the terminus of a street. The animal trap is an attempt to control the small animal population. Despite these issues, the dwelling was recently rebuilt, and the site improvements are in good condition. In its current condition, the property is not detrimental to the safety, health, morals, or welfare of the community, and it does not meet any criteria of the LRHL.

B. Analysis of the Study Area as a Whole

The results of the redevelopment area investigation reveal that some of the properties in the Study Area qualify for redevelopment designation under at least one of the criteria of the enabling statute. **Figure 5** illustrates which criteria are applicable for each parcel.

When evaluating the overall study area, various contiguous properties can be designated under the criteria of the LRHL. However, there are also small gaps of properties that do not meet the redevelopment criteria, whose lands, buildings, or improvements are not detrimental to the public safety, health, or welfare. These points of discontinuity prevent the Study Area’s effective

redevelopment, and therefore it is necessary to include certain properties in the redevelopment area, pursuant to the provision referred to as "Section 3" as set forth under N.J.S.A. 40A:12A-3.

Lot 2: This narrow, 37-foot-wide property is flanked on either side by larger parcels, namely Lots 1 and 3, that can be designated as in need of redevelopment under the LRHL. Lots 1, 2, and 3 form the entire street frontage along the east side of Mersereau Terrace between Graham Place and West Englewood Avenue. Lot 2 must be included in the redevelopment area under Section 3 to avoid a small gap and allow effective redevelopment of this side of Mersereau Terrace.

Lot 4.01: This property is flanked on either side by properties that can be designated as being in need of redevelopment, namely Lot 3 to the west and Lot 5 to the east. Lot 4.01 must be designated under Section 3 to avoid a gap and allow effective redevelopment of this block of West Englewood Avenue.

Lot 6: This property is flanked on either side by properties that can be designated as being in need of redevelopment, namely Lot 5 to the west and Lot 7, 8 and 9 to the east. adjacent properties meet the criteria for redevelopment designation. Lot 6 must be designated under Section 3 to avoid a gap and allow effective redevelopment of this block of West Englewood Avenue.

Lot 10: This is surrounded on all sides by properties that can be designated as being in need of redevelopment, namely Lots 7, 8, and 9 to the west; Lots 11 and 12 to the east; and Lot 13 to the south. Therefore, Lot 10 must be included in the redevelopment area to allow for effective redevelopment by avoiding a small gap in otherwise contiguous land that qualifies as an area in need of redevelopment.

Lot 14: This property is an L-shaped lot that wraps around Lots 15 and 17. It effectively divides the Teaneck Road commercial properties on this block into the northern collection of Lots 11, 12, and 13 and the southern collection of Lots 15 and 17, of which all can be designated under redevelopment criteria of the LRHL. In order to avoid dividing the redevelopment of the commercial corridor, and to avoid isolating redevelopment of Lots 15 and 17, Lot 14 must be included in the redevelopment area.

As a result of the overall study area analysis described above, substantial evidence exists to declare Block 4905, Lots 2, 4.01, 6, 10 and 14 as part of an "area in need of redevelopment" in accordance with the "Section 3" provision set forth in the State's Local Redevelopment and Housing Law.



Figure 5: Area in Need of Redevelopment Criteria
 Area in Need of Redevelopment Investigation
 Block 4905, Lots 1 - 22.01 | Township of Teaneck, New Jersey

VI CONCLUSION

The foregoing study was prepared on behalf of the Township of Teaneck Planning Board in order to determine whether the Study Area qualifies as a “non-condemnation area in need of redevelopment” as defined under the LRHL at N.J.S.A. 40A:12A. Based on the foregoing analysis, Block 4905, Lots 1, 3, 5, 7, 8, 9, 11, 12, 13, 15, and 17 meet the redevelopment designation criteria set forth at N.J.S.A. 40A:12A-5. Block 4905, Lots 2, 4.01, 6, 10, and 14 can be designated under Section 3 of the LRHL. Block 4905, Lots 18-22.01 do not meet any of the redevelopment designation criteria of the LRHL. Therefore, 18 of the 23 lots within the Study Area can be designated as an area in need of redevelopment.

| Block | Lot | Address | Current/Former Use | AINR Criteria |
|--------------|------------|------------------------------------|---|----------------------|
| 4905 | 1 | 61 GRAHAM PL | Residence | a, d |
| 4905 | 2 | 1347 MERSEREAU TERR | Residence, vacant | Section 3 |
| 4905 | 3 | 54 W ENGLEWOOD AVE | Residence, vacant | a, d |
| 4905 | 4.01 | 44 W ENGLEWOOD AVE | Residence | Section 3 |
| 4905 | 5 | 40 W ENGLEWOOD AVE | Residence, vacant | d |
| 4905 | 6 | 32 W ENGLEWOOD AVE | Residence | Section 3 |
| 4905 | 7 | 26 W ENGLEWOOD AVE | Residence | a, d |
| 4905 | 8 | 22 W ENGLEWOOD AVE | Residence | a, d, e |
| 4905 | 9 | 20 W ENGLEWOOD AVE | Residence | a, d |
| 4905 | 10 | 18 W ENGLEWOOD AVE | Residence | Section 3 |
| 4905 | 11 | 1360 TEANECK RD to 1364 TEANECK RD | Former Krispy Krunchy Chicken and Lahore Biryani & Grill (now vacant), Ebony Beauty Supplies | d |
| 4905 | 12 | 1354-1358 TEANECK RD | Former Ana S Beauty Salon (now vacant), Former H&R Discount Liquors (now vacant), Kimmy's Beauty Spa Nails, Reggae Kitchen | b, d, e |
| 4905 | 13 | 1348-1352 TEANECK RD | H&S Discount Liquors, Blimpie and Surf City Squeeze, parking | d |
| 4905 | 14 | 1344 TEANECK RD | Municipal parking lot | Section 3 |
| 4905 | 15 | 1338-1340 TEANECK RD | Office and retail: Leasco, Unique Styles Beauty Salon, Build Insurance Brokers, Access Computer Systems; parking garage and lot | d |
| 4905 | 17 | 1334 TEANECK RD | Elsa's Beauty Salon II; apartment; parking garage and lot | d |
| 4905 | 18 | 23 ORCHARD ST | Residence | None |
| 4905 | 19 | 27 ORCHARD ST | Residence | None |
| 4905 | 20 | 35 ORCHARD ST | Residence | None |
| 4905 | 21 | 43 ORCHARD ST | Residence | None |
| 4905 | 22.01 | 1335 GRAHAM PL | Residence | None |

APPENDICES

Appendix A: Study Area Photographs.

Appendix B: Resolution of the Town Council authorizing the redevelopment investigation.

Appendix C: Municipal Records (Tax Assessor, Tax Collector, Health Department, Police Department, Building Department, Township Engineer).

Appendix A:

Study Area Photographs

BLOCK 4905
LOT 1



BLOCK 4905
LOT 2



BLOCK 4905
LOT 3



BLOCK 4905
LOT 4.01



BLOCK 4905
LOT 5



BLOCK 4905
LOT 6



BLOCK 4905
LOT 7



BLOCK 4905
LOT 8



BLOCK 4905
LOT 9



BLOCK 4905
LOT 10



Photograph Appendix
Area in Need of Redevelopment Investigation
Block 4905, Lots 1 - 22.01 | Township of Teaneck, New Jersey
PHILLIPS PREISS GRYGIEL LEHENY HUGHES LLC 2022

BLOCK 4905
LOT 11



BLOCK 4905
LOT 11



BLOCK 4905
LOT 12



Photograph Appendix
Area in Need of Redevelopment Investigation
Block 4905, Lots 1 - 22.01 | Township of Teaneck, New Jersey
PHILLIPS PREISS GRYGIEL LEHENY HUGHES LLC 2022

BLOCK 4905
LOT 12



BLOCK 4905
LOT 13



BLOCK 4905
LOT 14



BLOCK 4905
LOT 15



BLOCK 4905
LOT 17



BLOCK 4905
LOT 18



BLOCK 4905
LOT 19



Photograph Appendix
Area in Need of Redevelopment Investigation
Block 4905, Lots 1 - 22.01 | Township of Teaneck, New Jersey
PHILLIPS PREISS GRYGIEL LEHENY HUGHES LLC 2022



BLOCK 4905
LOT 21



BLOCK 4905
LOT 22.01



Appendix B:

Resolutions of the Township Council authorizing redevelopment investigation,
adopted May 17, 2022.



Township Council

c/o Township Clerk
Teaneck, NJ 07666

Meeting: 05/17/22 08:00 PM

Department: Township Clerk

Category: Authorization

DOC ID: 7245

RESOLUTION 127-2022

**AUTHORIZING AND REQUESTING THE PLANNING BOARD OF THE TOWNSHIP
OF TEANECK TO UNDERTAKE A PRELIMINARY INVESTIGATION AS TO
WHETHER BLOCK 4905, LOTS 1 THRU 22.01 MAY BE DETERMINED TO BE AN
AREA IN NEED OF REDEVELOPMENT**

TOWNSHIP OF TEANECK
BERGEN COUNTY, NJ

127-2022

**AUTHORIZING AND REQUESTING THE PLANNING BOARD OF THE
TOWNSHIP OF TEANECK TO UNDERTAKE A PRELIMINARY
INVESTIGATION AS TO WHETHER BLOCK 4905, LOTS 1 THRU 22.01
MAY BE DETERMINED TO BE AN AREA IN NEED OF
REDEVELOPMENT**

BE IT RESOLVED by the Township Council of the Township of Teaneck, Bergen County, New Jersey, pursuant to N.J.S.A. 40A:12A-6, as follows:

1. The Planning Board of the Township of Teaneck is hereby authorized and requested to undertake a preliminary investigation as to whether the areas known being also known and designated as Block 4905, Lots 1 thru 22.01, as shown on the Tax Map of the Township of Teaneck, may be determined to be areas in need of redevelopment in accordance with the criteria set forth in N.J.S.A. 40A:12A-5.
2. The redevelopment area determination shall authorize the Township of Teaneck to use all those powers provided by the Legislature for use in a redevelopment area other than the use of eminent domain (Non-Condensation Redevelopment Area).
3. The Planning Board of the Township of Teaneck, in accordance with the requirements of N.J.S.A. 40A:12A-6 shall prepare a map showing the boundaries of the proposed redevelopment areas and the location of the various parcels of property located therein and shall append to the map a statement setting forth the basis for the investigation.

4. The Planning Board of the Township of Teaneck shall specify a date for and give notice of a hearing for the purpose of hearing persons who are interested in or who would be affected by a determination that the delineated areas are redevelopment areas.
5. The hearing notice shall set forth the general boundaries of the area to be investigated and state that a map has been prepared and can be inspected at the office of the Township Clerk. In addition the notice shall state that the redevelopment determination shall establish a Non-Condernation Redevelopment Area and that a redevelopment area determination shall not authorize the Township of Teaneck to exercise the power of eminent domain to acquire any property within the delineated area.
6. A copy of the notice shall be published in the Record once each week for two consecutive weeks, the last publication to be not less than ten days prior to the date set for the hearing. In addition, a copy of the notice shall be mailed at least ten days prior to the date set forth for the hearing to the owner of each parcel of property within the area according to the assessment records of the Township of Teaneck and to all persons at their last known address, if any, whose names are noted on the assessment records as claimants of an interest in any such parcel.
7. At the hearing, which may be adjourned from time to time, the Planning Board shall hear all persons who are interested in or who would be affected by a determination that the delineated areas are redevelopment areas. All objections to such a determination and evidence in support of those objections, given orally or in writing, shall be received and considered and made part of the public record.

8. After completing its hearing on this matter, the Planning Board shall recommend to the Township Council that the delineated areas, or any part thereof, be determined, or not be determined, by the Township Council to be a redevelopment area.



Township Council

c/o Township Clerk
Teaneck, NJ 07666

Meeting: 05/17/22 08:00 PM

Department: Township Clerk

Category: Authorization

DOC ID: 7244

RESOLUTION 129-2022

**THORIZING PHILLIPS, PREISS, GRYGIEL, LEHENY, HUGHES LLC TO
UNDERTAKE PROFESSIONAL PLANNING SERVICES IN CONNECTION WITH THE
POTENTIAL REDEVELOPMENT OF BLOCK 4905 IN THE TOWNSHIP OF TEANECK**

TOWNSHIP OF TEANECK
BERGEN COUNTY, NJ

129-2022

**THORIZING PHILLIPS, PREISS, GRYGIEL, LEHENY, HUGHES LLC
TO UNDERTAKE PROFESSIONAL PLANNING SERVICES IN
CONNECTION WITH THE POTENTIAL REDEVELOPMENT OF
BLOCK 4905 IN THE TOWNSHIP OF TEANECK**

WHEREAS, the Township of Teaneck is in need of the services of a professional planning consultant to perform professional planning services in connection with the potential redevelopment of Block 4905 as shown on the Tax map of the Township of Teaneck, including assisting the Planning Board in an investigation of whether the area is an area in need of redevelopment; and

WHEREAS, such services constitute professional services as that term is defined in N.J.S.A. 40A:11-2; and

WHEREAS, the Township of Teaneck has received a proposal therefor from Phillips Preiss Grygiel Leheny Hughes LLC, Planning and Real Estate Consultants (hereinafter the "Professional Consultant"), to perform an investigation as to whether the proposed redevelopment area is an area in need of redevelopment pursuant to N.J.S.A. 40A:12A-6 at a cost not to exceed \$12,000.00 to be paid through escrows posted by the proposed redeveloper; and

WHEREAS, the Local Public Contracts Law (N.J.S.A. 40A:11-1 et seq.) authorizes the execution of professional services contracts without competitive bidding; and

WHEREAS, the Township of Teaneck has retained the Professional Consultant to perform various professional planning services including various redevelopment studies, investigation of areas in need of redevelopment, Master Plan Reexamination

Reports and preparation of Zoning Ordinance amendments within the Township of Teaneck on an “as requested” basis; and

WHEREAS, the Township Council finds and concludes that it would be in the best interests of the Township of Teaneck to enter into a professional services agreement with the Professional Consultant based upon the Professional Consultant’s expertise in planning matters, extensive planning experience, familiarity with the Township of Teaneck and the Professional Consultant’s cost proposal; and

WHEREAS, the Municipal Manager has determined and certified in writing that the anticipated payments under said contract, when added to previous authorizations, will exceed \$17,500; and

WHEREAS, the Professional Consultant has completed and submitted a Business Entity Disclosure Certification which certifies that the Consultant has not made any reportable contributions to a political or candidate committee pursuant to N.J.S.A. 19:44A-1 et seq. that, pursuant to P.L. 2004, c.19, as amended by P.L. 2005, c.51, or pursuant to Ordinance 19-2017 of the Township of Teaneck would bar the award of this contract in the previous one year period preceding the award of this contract, and that the contract will prohibit the Consultant from making any reportable contributions during the term of the contract; and

WHEREAS, the within agreement is contingent upon the proposed developer posting sufficient funds to pay for the cost thereof; and

NOW, THEREFORE, BE IT RESOLVED by the Township Council of the Township of Teaneck, Bergen County, New Jersey, that, subject to the funding of a cash escrow sufficient to pay the cost thereof, Phillips Preiss Grygiel Leheny Hughes LLC, Planning and Real Estate Consultants, having their offices at 70 Hudson Street,

Suite 5B, Hoboken, N.J. 07030, are hereby authorized to undertake professional planning services in connection with the potential redevelopment of Block 4905 as shown on the Tax Map of the Township of Teaneck, including assisting the Planning Board in a an investigation of whether the area is an area in need of redevelopment, and, if authorized by the Township of Teaneck, the preparation of a redevelopment plan, and the review of various studies respecting traffic, parking, geotechnical factors, environmental impact, fiscal impact, infrastructure impact and other planning considerations in connection with said proposed redevelopment; and BE IT FURTHER

RESOLVED that the Mayor is hereby authorized to sign and the Township Clerk to attest a contract on behalf of the Township of Teaneck, with Phillips Preiss Grygiel Leheny Hughes LLC, Planning and Real Estate Consultants to carry out the foregoing purposes, a copy of which is on file in the Office of the Township Clerk and is available for public inspection; and BE IT FURTHER

RESOLVED that the Township Clerk is hereby directed to cause a brief notice of this contract to be published in a newspaper circulated within the Township of Teaneck stating the nature, duration, services and amount of the contract and that a copy of the resolution and contract are to be maintained on file with the Township Clerk and are available to be for public inspection during regular business hours in the office of the Township Clerk.

Appendix C:

Municipal Records: Tax Assessor

4905/11/0001

RECORD OF OWNERSHIP

TEANECK TOWNSHIP

BLOCK: 4905 LOT: 11 QUAL: C0001 CLASS: 4A
LOCATION: 1360 Teaneck Road

OWNER: Jung, Jooho & Lee, Chong Im
ADDRESS: 1360 Teaneck Rd
CITY, STATE, ZIP: Teaneck, Nj 07666

LOT SIZE: ZONE: R01

YEAR BUILT:

| OWNER | DEED DATE | DATE REC. | BOOK | PAGE | SRIA NO. | USABLE | RATIO | SALE PRICE |
|-------|-----------|-----------|------|------|----------|--------|-------|------------|
| | | | | | | | | |
| | | | | | | | | |
| | | | | | | | | |
| | | | | | | | | |
| | | | | | | | | |
| | | | | | | | | |
| | | | | | | | | |
| | | | | | | | | |
| | | | | | | | | |
| | | | | | | | | |

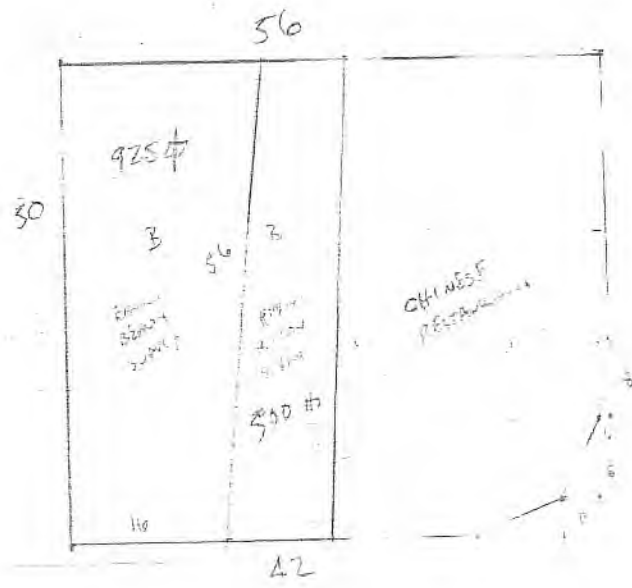

GROSS BUILDING AREA:

GROUND AREA:

PERIMETER:

WALL RATIO:

AVERAGE STORY HEIGHT:

NOTES:

4905/11/0002

| | | | | | | | |
|---|---------|-------------------------------|---------------------------------|----------------------|--------|--------------------------------------|----------------------|
| BUILDING CLASS | | OBSERVED PHYSICAL CONDITION | | YEAR BUILT | | TYPE: | |
| | | GOOD _ NORMAL _ FAIR _ POOR _ | | EFFECTIVE AGE | | USE | |
| 1. STRUCTURAL SHELL | | 3. INTERIOR FINISH | | 5. PLUMBING | | 8. STD. BLDG. ACCESS (cont'd) | |
| DESCRIPTION | Q | FI/Sec | Apt. Area: | DESCRIPTION | Q | No. | FA Floor Adjustments |
| 101 Light Wood | | | No. Units | 3 Fix't. Bath | | | Concrete Slab |
| 102 Heavy Timber | | | No. Rooms | 2 Fix't. Toilet | | | Wood Deck |
| 103 Mas. Ld. (Bearing) | | | DESCRIPTION | Lavatory | | | Concrete Deck |
| 104 Reinforced Conc. | | | 1. Apartment | Shower Stall | | | Rein. Concrete |
| 105 Steel | | | 2. Apt. Utility Area | Toilet | | | Grating Type |
| 106 Fireproof-Steel | | | 3. Motel, Hotel | Urinal | | | RA Roof Adjustments |
| 107 Steel w/Gal. Steel | | | 4. Sm. Offices | Sink, Kitchen | | | Light Wood |
| 108. Steel w/Alum ext. | | | 5. Lg. Open Offices | Sink, Slop | | | Heavy Timber |
| 109 Steel w/Ins Sand | | | 6. Professional Office | Ind. Sink | | | Steel Deck |
| 110-111 Basement | | | 7. Clinics | TOTALS | | | Concrete |
| None | Full | | 8. Lg. Open Stores | 1. Apartment | | | Galv. Steel |
| Partial | Sq. Ft. | | 9. Small Stores | 2. Commercial | | | Enam. Steel |
| Finished | Sq. Ft. | | 10. Bank | 3. Industrial | | | Insul. Panel |
| Type of Finish | | | 11. Warehouse | 6. ELECTRICAL | | | Precast Concrete |
| Basement Floor Construction: | | | 12. Light Mfg. Area | TYPE Intensity | | | Canopies |
| DIRT <input type="checkbox"/> Wood <input type="checkbox"/> Conc. <input type="checkbox"/> | | | 13. Heavy Mfg. Area | Q | FI/Sec | | WR Roof Span Wd. |
| First Floor Construction: | | | FINISHED FLOORING | | | | Type |
| Wood <input type="checkbox"/> Conc. <input type="checkbox"/> Steel <input type="checkbox"/> | | | 1. Apartment | Bright | | | Qual. |
| | | | | Adeq. | | | |
| | | | | Min. | | | |
| 123 - 127 Service Station | | | Asphalt Tile | 2. Commercial | Bright | | Other Accessories |
| 133 - 137 Specialty Building | | | Terazzo | | Adeq. | | |
| 145 Garden Apartments | | | Ceramic Tile | | Min. | | |
| 2. EXTERIOR WALL FINISH | | Other: | | 3. Industrial | Bright | | |
| DESCRIPTION | Q | FI/Sec | CEILINGS | | | | |
| 1. Plywood, Gal. Steel | | | Plaster | Accoustical Tile | | | |
| 2. Wd. Siding, Asbestos | | | Sheetrock | Suspended | | | ELEVATORS |
| 3. Cement Block | | | Other: | | | | Type |
| 4. Wood Sheathing/Sid. | | | 4. HEATING & COOLING | | | | Auto |
| 5. Common Brk. on C.B. | | | DESCRIPTION | Q | FI/Sec | | Cap. |
| 6. Face Brk. on W.D. | | | 1. Apartment | | | | Floors |
| 7. Face Brk. on C.B. | | | 2. Commercial | | | | |
| 8. Com. Brk./Re. C. | | | 3. Industrial | | | | |
| 9. Face Brk. on Re. C. | | | 4. Central Cooling | | | | |
| 10. Precast Panels | | | 5. Package Cooling | | | | |
| 11. Metal & Glass | | | 6. Central Combined | | | | |
| 12. Stone | | | 7. Package Combined | | | | |
| 13. Slate, Limestone | | | 8. Min. Industrial Unit Heaters | | | | |
| 14. Marble | | | Sm. Med. Lg. | | | | |
| 15. Granite | | | 9. Individ. Wall Sleeve Units | | | | |
| 16. Store Front | | | Sm. Med. Lg. | | | | |

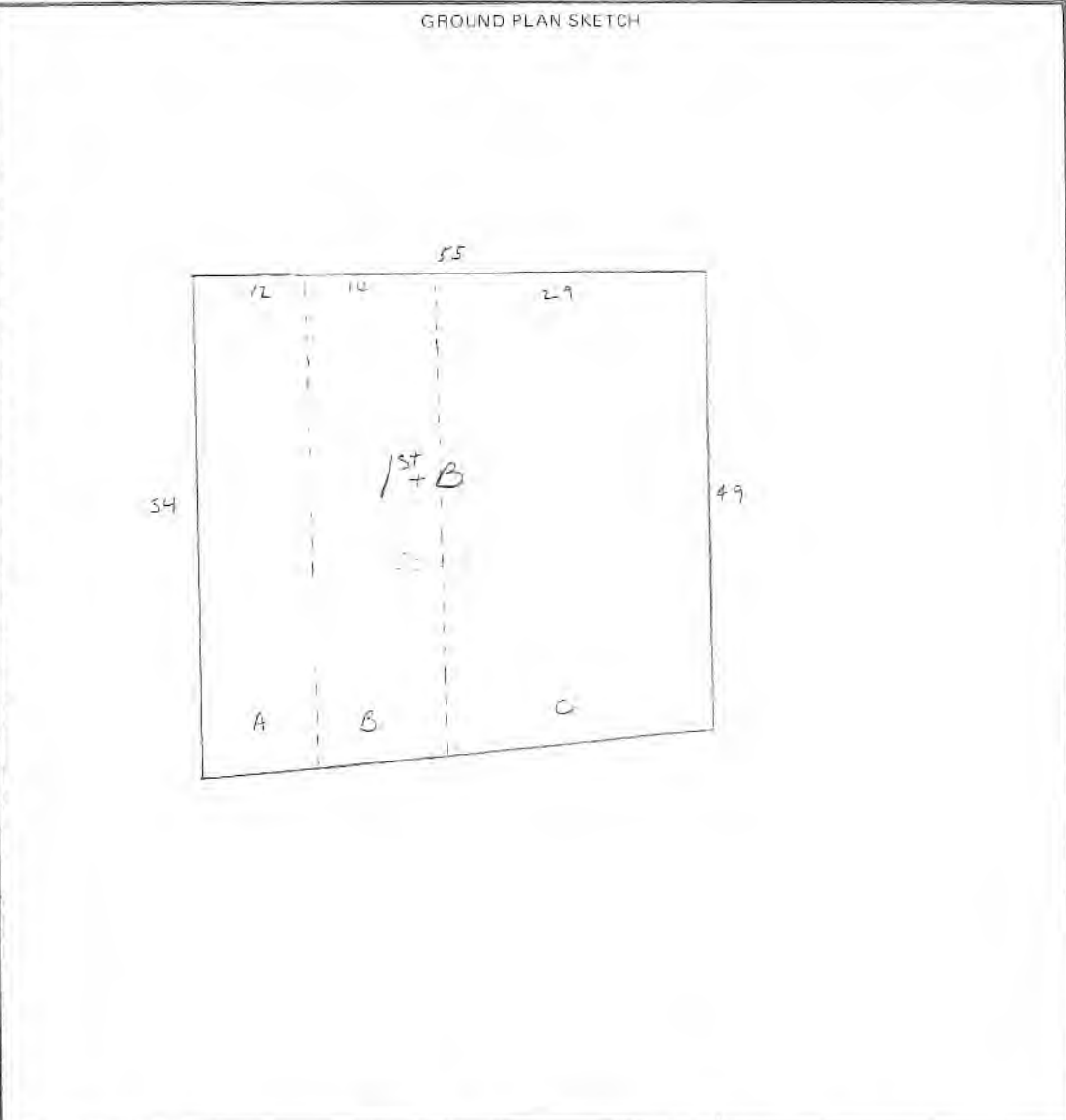

| | | |
|--|-----------|------------|
| GROUND AREA | PERIMETER | WALL RATIO |
| NOTES: A - NEWS LINE START MARK B - LOSS BARRELS C - FINISH FLOOR MARK | | |
| INITIAL: | MEAS BY: | DATE: |
| | VALUE BY: | DATE: |

TEANECK COMMERCIAL

SC: CONDO .0362/ACRE: 0.04/SALE DATE: 5/11/2005

B: 4905 C: 11 Q: C0003 CU: 41A

041474

4905/11/C0003

Card _____ of _____

RECORD OF OWNERSHIP

| OWNER | Deed Date | Date Reg | Book | Page | SRIA # | Usable | Ratio | Sale Price |
|-------|-----------|----------|------|------|--------|--------|-------|------------|
| | | | | | | | | |
| | | | | | | | | |
| | | | | | | | | |
| | | | | | | | | |

PROPERTY USE: Retail

NOTES

John's Fish Market

EXT. ACCESSOR.

| | |
|--------------|----------|
| Conc. Paving | Lighting |
| Black Top | Fences |
| Curbing | Islands |

VERIFICATION OF INSPECTION:

MEASURED BY: *CSJ*

DATE: *4/2*

INSPECTED BY: *CSJ*

DATE: *11/2*

GROUND AREA: *724*

GROSS BLDG AREA: *724*

HEIGHT: *12*

[Signature]

Block: 4905 Land Desc: 106X145 Owners Name: SADIQULLA, MOHAMMED Land: 166,600 Exemption Net Taxable Value Deductions
 Lot: 3 Bldg Desc: 2S-AL-0-1UG Street Address: 94 JACKSON DRIVE Bank: 00000 Impr: 187,000 Code: Cd No-Ow
 Qual: Add Lots: City & State: CRESSKILL, NJ Zip: 07626 Total: 353,600 Value: 0 353,600
 Card: M (#1 of 1) Acreage: 0.353 Class: 2 Property Loc: 54 W ENGLEWOOD AVE Zone: R01 Map: TEANECK

| SALES HISTORY | | | | | ASSESSMENT HISTORY | | | | BUILDING PERMITS/REMARKS | | | |
|-----------------------------|----------|-------------|--------|-----|--------------------|--------|--------|--------|--------------------------|------------------|--------|--------|
| Grantor | Date | Book/Page | Price | Nu# | Year | Land | Impr | Total | Date | Work Description | Amount | Compl. |
| NATIONSTAR MORTGAGE LLC | 10/10/18 | 3095 /2360 | 250000 | 31 | 2014 | 236700 | 101500 | 338200 | | | | |
| SAUDINO, MICHAEL BC SHERIFF | 06/12/18 | 3039 /2317 | 100 | 12 | | | | | | | | |
| | 00/00/00 | 7968 /365 | 150000 | 13 | | | | | | | | |
| | 04/23/97 | 07968/00365 | 150000 | | | | | | | | | |

| LAND CALCULATIONS | | | | | | | | | | | |
|-------------------|----|----|---|----|---------|------|-----|--------|---------|-------------|---------|
| Frnt | Rr | SB | T | FF | Avgd | Tabl | EqF | Rate | Site | Cond | Value |
| | | | | | | | | | | | |
| TRAFFIC | | | | | 95 | | | | | | |
| | | | | | Units | | | Rate | Site | Cond | Value |
| | | | | | 7500 SF | | | 7.00 | 105000 | 100 100 100 | 157500 |
| | | | | | 2500 SF | | | 5.00 | | 100 100 100 | 12500 |
| | | | | | 5367 SF | | | 1.00 | | 100 100 100 | 5367 |
| Net Adj: | | | | | 95.00 | SF: | | 15,367 | Auto: Y | Land Value: | 166,598 |

| SITE INFORMATION | |
|-----------------------|---|
| Road: PAVED | Utilities: Sewer: YES Water: YES Gas: YES |
| Curbs: YES | Measured: AK |
| Sidewalk: YES | Topo: LEVEL |
| Inspected: N | Neigh: 12 |
| 03/25/14 | VCS: SF12 |

| RESIDENTIAL COST APPROACH | | | |
|-------------------------------|--------|----------------------------|--------|
| Basement | | | |
| BASEMENT | 943 x | 9.520 + 2160 x1.00 x1.00= | 11137 |
| BASEMENT FIN | 708 x | 13.510 + 1176 x1.00 x1.00= | 10741 |
| Main Bldg | | | |
| FIRST STORY | 943 x | 49.390 +22230 x1.00 x1.00= | 68805 |
| UPPER STORY | 840 x | 34.990 + 6664 x1.00 x1.00= | 36056 |
| Heat/AC | | | |
| HW BASEBOARD | 2827 x | 3.760 + 0 x1.00 x1.00= | 10630 |
| Plumbing | | | |
| 3 FIXTURE BATH | 2- 2 | x2595.000 + 0 x1.00 x1.00= | 0 |
| 2 FIXTURE BATH | 1- 1 | x1895.000 + 0 x1.00 x1.00= | 0 |
| Fireplace | | | |
| Attic | | | |
| DORMER | 18 x | 129.000 + 0 x1.00 x1.00= | 2322 |
| FIN ATTIC | 840 x | 8.810 + 1080 x1.00 x1.00= | 8480 |
| Deck/Patio/Garage/Misc | | | |
| ENCLOSED PORCH | 20 x | 27.150 + 1080 x1.00 x1.00= | 1623 |
| OPEN PORCH | 377 x | 10.773 + 453 x1.00 x1.00= | 4514 |
| PATIO | 714 x | 5.610 + 0 x1.00 x1.00= | 4006 |
| | | | 397900 |

| BUILDING INFORMATION | |
|--|--|
| Type and Use: ONE FAMILY | Class/Quality: 16 |
| Story Height: | Condition: TYPICAL |
| Style: SMALL COLONIAL | Year Built/EffA: 1909 / 99 (Y) |
| Exterior Finish: ALUM/VINYL | Windows: |
| Roof Type: HIP | Livable Area: 2119 SF |
| Roof Material: ASPHALT SHINGLE | Interior Cond: ESTIMATE |
| Foundation: CONCRETE BLOCK | Interior Wall: PLASTER |
| Baths: M:1 A:2 O: | |
| Kitchens: M:41 A: O: | |

| ROOM COUNT | | | | | |
|-------------|---|---|---|-----|----------|
| | B | 1 | 2 | 3/A | Tot |
| Living Rm | | 1 | | | 1 |
| Dining Rm | | 1 | | | 1 |
| Kitchen | | 1 | | | 1 |
| Dinette | | | | | |
| 5 Fixt Bath | | | | | |
| 4 Fixt Bath | | | | | |
| 3 Fixt Bath | 1 | | 1 | | 2 |
| 2 Fixt Bath | | 1 | | | 1 |
| Bed Room | | | 4 | | 4 |
| Fam Room | | | | | |
| Den/Other | 1 | | | 1 | 2 |
| Old B: | | | | | 8 |
| Old L: | | | | | 06/30/22 |

| | | | |
|-----------------------------|----------------------|----------------------------------|---------------------------|
| Base Cost: 158314 | CCF: 135 | CLA: 110 | Cost New: 235096 |
| Phys Depr: 22.88 (Y) | Func Depr: | | Net Depr: 77.12 |
| Loc Depr: | Mkt+: | Mkt-: | Bldg Value: 181316 |
| Detached Items: | | | |
| DETACHED GA | 350 x | 15.950 + 3084 x1.00 x0.37 x1.35= | 4329 |
| SHED 1STY | 210 x | 14.730 + 996 x1.00 x0.25 x1.35= | 1380 |
| Land: 166,600 | Impr: 187,000 | Total: | 353,600 |

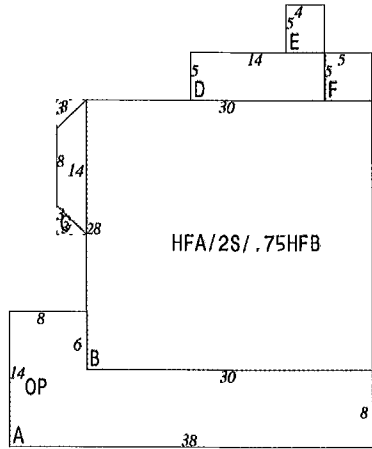

A:OP u0 r0;u14 r8 d6 r30 d8 l38
 B:HFA/2S/.75HFB u8 r8;u28 r30
 C:1S/.75HFB u22 r8;w3 n3 u8 n3 e3 d14
 D:1S/.75HFB u36 r19;u5 r14
 E:EP u41 r29;u5 r4
 F:OP u36 r33;u5 r5
 G:CPA 714
 H:
 I:
 J:
 K:
 L:

352
840
33
70
20
25
714
0

M:
N:
O:
P:

Scale: 20

Block: 4905 Land Desc: 55X140 Owners Name: ORDUKHANYAN, ASHOT Land: 150,600 Exemption Net Taxable Value Deductions
 Lot: 4.01 Bldg Desc: 2S-AL-S-1AG Street Address: 44 WEST ENGLEWOOD AVE Bank: 01107 Impr: 176,700 Code: Cd No-Ow
 Qual: Addl Lots: City & State: TEANECK, N.J. Zip: 07666 Total: 327,300 Value: 0 327,300
 Card: M (#1 of 1) Acreage: 0.177 Class: 2 Property Loc: 44 W ENGLEWOOD AVE Zone: R01 Map: TEANECK

| SALES HISTORY | | | | | ASSESSMENT HISTORY | | | | BUILDING PERMITS/REMARKS | | | |
|---------------|----------|-----------|-------|-----|--------------------|--------|--------|--------|--------------------------|------------------|--------|--------|
| Grantor | Date | Book/Page | Price | Nu# | Year | Land | Impr | Total | Date | Work Description | Amount | Compl. |
| | 09/04/01 | 8409 /550 | | 1 1 | 2021 | 150600 | 176700 | 327300 | | | | |
| | | | | | 2022 | 150600 | 176700 | 327300 | | | | |

| LAND CALCULATIONS | | | | | | | | | | SITE INFORMATION | | | | RESIDENTIAL COST APPROACH | | | |
|-------------------|----|----|---|----|------|------|-----|------|------|------------------|-------|---------------|------------|---------------------------|-----------------------------------|--------|--------|
| Frt | Rr | SB | T | FF | Avgd | Tabl | EqF | Rate | Site | Cond | Value | Road: | Utilities: | Basement | Work Description | Amount | Compl. |
| | | | | | | | | | | | | PAVED | Sewer: YES | BASEMENT | 352 x 9,580 + 2112 x1.15 x1.00= | 6307 | |
| | | | | | | | | | | | | Curbs: YES | Water: YES | Main Bldg | | | |
| | | | | | | | | | | | | Sidewalk: YES | Gas: YES | FIRST STORY | 1116 x 58,980 +27060 x1.00 x1.00= | 92882 | |
| | | | | | | | | | | | | Measured: AK | Topo: | UPPER STORY | 680 x 42,070 + 8008 x1.00 x1.00= | 36616 | |
| | | | | | | | | | | | | Inspected: Y | Neigh: 12 | BRICK SF | 112 x 11,430 + 30 x1.15 x1.00= | 1507 | |
| | | | | | | | | | | | | 03/25/14 | VCS: SF12 | SLAB | 476 x -1.120 +-1080 x1.14 x1.00= | -1839 | |
| | | | | | | | | | | | | | | Heat/AC | | | |
| | | | | | | | | | | | | | | HW BASEBOARD | 1796 x 3,250 + 1200 x1.15 x1.00= | 8093 | |
| | | | | | | | | | | | | | | AC SEPARATE DUC | 1796 x 1,530 + 2400 x1.12 x1.00= | 5766 | |
| | | | | | | | | | | | | | | Plumbing | | | |
| | | | | | | | | | | | | | | 3 FIXTURE BATH | 2- 2 x2595.000 + 0 x1.12 x1.00= | 0 | |
| | | | | | | | | | | | | | | 2 FIXTURE BATH | 0- 1 x1895.000 + 0 x1.12 x1.00= | -2122 | |
| | | | | | | | | | | | | | | Fireplace | | | |
| | | | | | | | | | | | | | | Attic | | | |
| | | | | | | | | | | | | | | Deck/Patio/Garage/Misc | | | |
| | | | | | | | | | | | | | | OPEN PORCH | 32 x 10,770 + 443 x1.15 x1.00= | 906 | |
| | | | | | | | | | | | | | | PATIO | 270 x 5,203 + 203 x1.15 x1.00= | 1849 | |
| | | | | | | | | | | | | | | ATTACHED GARAGE | 252 x 15,170 + 2364 x1.13 x1.00= | 6991 | |
| | | | | | | | | | | | | | | 440500 | | 0 | |

| LAND CALCULATIONS | | | | | | | | | | | |
|-------------------|-------|----|---|----|------|---------|-----|---------|-------------|-------------|--------|
| Frt | Rr | SB | T | FF | Avgd | Tabl | EqF | Rate | Site | Cond | Value |
| TRAFFIC | | | | | 95 | | | | | | |
| | | | | | | Units | | Rate | Site | Cond | Value |
| | | | | | | 7500 SF | | 7.00 | 105000 | 100 100 100 | 157500 |
| | | | | | | 201 SF | | 5.00 | | 100 100 100 | 1005 |
| Net Adj: | 95.00 | | | | SF: | 7,701 | | Auto: Y | Land Value: | 150,579 | |

| BUILDING INFORMATION | | | | | | | | | |
|----------------------|----------------|---------------|------------|-------------|------------------|------------------|----------|-----------------|----------------|
| Type and Use: | Class/Quality: | Story Height: | Condition: | Style: | Year Built/EffA: | Exterior Finish: | Windows: | Roof Type: | Livable Area: |
| ONE FAMILY | 17 | | TYPICAL | SPLIT LEVEL | 1979 / 35 (Y) | ALUM/VINYL BRICK | | HIP | 1796 SF |
| | | | | | | | | Roof Material: | Interior Cond: |
| | | | | | | | | ASPHALT SHINGLE | TYPICAL |
| | | | | | | | | Foundation: | Interior Wall: |
| | | | | | | | | CONCRETE BLOCK | SHEETROCK |
| Baths: M:1 A:1 O: | | | | | | | | | |
| Kitchens: M: A:1 O: | | | | | | | | | |

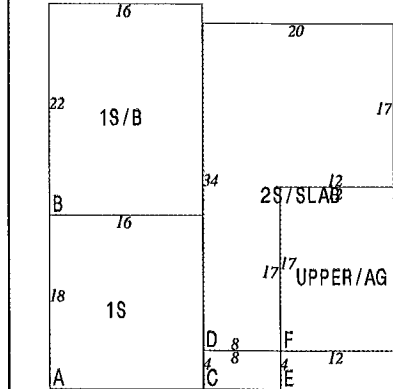

| | | |
|-------------|-------------------------------|-----|
| A: 1S | u0 r0;u18 r16 | 288 |
| B: 1S/B | u18 r0;u22 r16 | 352 |
| C: OP | u0 r16;u4 r8 | 32 |
| D: 2S/SLAB | u4 r16;u34 r20 d17 l12 d17 l8 | 476 |
| E: AG | u0 r24;u4 r12 | 48 |
| F: UPPER/AG | u4 r24;u17 r12 | 204 |
| G: | | 0 |
| H: CPA | 270 | 270 |
| I: | | |
| J: | | |
| K: | | |
| L: | | |

Scale: 20
 Copyright (c) 1999 MicroSystems-NJ.Com, L.L.C.

| ROOM COUNT | | | | | |
|-------------|------|---|---|-----|----------|
| | B | 1 | 2 | 3/A | Tot |
| Living Rm | | 1 | | | 1 |
| Dining Rm | | 1 | | | 1 |
| Kitchen | | 1 | | | 1 |
| Dinette | | | | | |
| 5 Fixt Bath | | | | | |
| 4 Fixt Bath | | | | | |
| 3 Fixt Bath | | 1 | 1 | | 2 |
| 2 Fixt Bath | | | | | |
| Bed Room | | | 3 | | 3 |
| Fam Room | | 1 | | | 1 |
| Den/Other | | | | | |
| Old B: | 4905 | | | | 7 |
| Old L: | 22 | | | | 06/30/22 |

| | | | | | |
|-----------------|-----------|-------------|----------|-------------|---------|
| Base Cost: | 156956 | CCF: 135 | CLA: 100 | Cost New: | 211891 |
| Phys Depr: | 16.63 (Y) | Func Depr: | | Net Depr: | 83.38 |
| Loc Depr: | | Mkt+: Mkt-: | | Bldg Value: | 176664 |
| Detached Items: | | | | | |
| Land: | 150,600 | Impr: | 176,700 | Total: | 327,300 |

Block: 4905 Land Desc: 50X184 Owners Name: 40 WEST ENGLEWOOD LLC Land: 157,800 Exemption Net Taxable Value Deductions
 Lot: 5 Bldg Desc: 2S-F-0- Street Address: 40 W ENGLEWOOD AVE Bank: 00000 Impr: 203,500 Code: Cd No-Ow
 Qual: Addl Lots: City & State: TEANECK, NJ Zip: 07666 Total: 361,300 Value: 0 361,300
 Card: M (#1 of 1) Acreage: 0.212 Class: 2 Property Loc: 40 W ENGLEWOOD AVE Zone: R01 Map: TEANECK

| SALES HISTORY | | | | | ASSESSMENT HISTORY | | | | BUILDING PERMITS/REMARKS | | | |
|------------------------------|----------|-------------|--------|-----|--------------------|--------|--------|--------|--------------------------|-----------------------------|--------|----------|
| Grantor | Date | Book/Page | Price | Nu# | Year | Land | Impr | Total | Date | Work Description | Amount | Compl. |
| IGLESIA(MERCY CHURCH OF GOD) | 01/20/22 | 4571 /713 | 550000 | | 2021 | 157800 | 203500 | 361300 | 07/14/16 | FINISH BASEMENT BATH/OFFICE | 21800 | 04/11/17 |
| | 08/03/06 | 9127 /470 | 400000 | | 2022 | 157800 | 203500 | 361300 | 11/22/02 | ALTERATIONS | 70600 | 08/15/03 |
| | 02/25/04 | 08675/00477 | 370000 | | | | | | | | | |
| LONG (ATTNY IN FACT), THOMAS | 09/18/02 | 08512/00888 | 166000 | 10 | | | | | | | | |

| LAND CALCULATIONS | | | | | | | | | | | |
|-------------------|-------|----|---|----|---------|------|-----|-------|---------|-------------|---------|
| Fr | Rr | SB | T | FF | Avgd | Tabl | EqF | Rate | Site | Cond | Value |
| | | | | | | | | | | | |
| TRAFFIC | | | | | 95 | | | | | | |
| | | | | | Units | | | Rate | Site | Cond | Value |
| | | | | | 7500 SF | | | 7.00 | 105000 | 100 100 100 | 157500 |
| | | | | | 1718 SF | | | 5.00 | | 100 100 100 | 8590 |
| Net Adj: | 95.00 | | | | SF: | | | 9,217 | Auto: Y | Land Value: | 157,785 |

| SITE INFORMATION | |
|------------------|------------|
| Road: | PAVED |
| Curbs: | YES |
| Sidewalk: | YES |
| Measured: | EB |
| Inspected: | N |
| | 04/02/14 |
| Utilities: | Sewer: YES |
| | Water: YES |
| | Gas: YES |
| Topo: | LEVEL |
| Neigh: | 12 |
| VCS: | SF12 |

| RESIDENTIAL COST APPROACH | |
|---------------------------|---|
| Basement | |
| BASEMENT | 900 x 9.520 + 2160 x1.00 x1.00= 10728 |
| BASEMENT FIN | 675 x 13.330 + 1302 x1.00 x1.00= 10300 |
| Main Bldg | |
| FIRST STORY | 1200 x 49.140 +22464 x1.00 x1.00= 81432 |
| UPPER STORY | 900 x 35.170 + 6498 x1.00 x1.00= 38151 |
| Heat/AC | |
| HOT WATER OR ST | 2775 x 4.430 + 0 x1.00 x1.00= 12293 |
| Plumbing | |
| 3 FIXTURE BATH | 2- 2 x2595.000 + 0 x1.00 x1.00= 0 |
| 2 FIXTURE BATH | 0- 1 x1895.000 + 0 x1.00 x1.00= -1895 |
| Fireplace | |
| Attic | |
| Deck/Patio/Garage/Misc | |
| OPEN PORCH | 72 x 10.920 + 437 x1.00 x1.00= 1223 |

| BUILDING INFORMATION | |
|----------------------|-----------------|
| Type and Use: | ONE FAMILY |
| Class/Quality: | 16 |
| Story Height: | |
| Condition: | UPDATES |
| Style: | SMALL COLONIAL |
| Year Built/EffA: | 1890 / 25 (N) |
| Exterior Finish: | ALUM/VINYL |
| Windows: | |
| Roof Type: | HIP |
| Livable Area: | 2100 SF |
| Roof Material: | ASPHALT SHINGLE |
| Interior Cond: | TYPICAL |
| Foundation: | CONCRETE BLOCK |
| Interior Wall: | SHEETROCK |
| Baths: | M: A: 2 O: |
| Kitchens: | M: A: 1 O: |

| ROOM COUNT | | | | | |
|-------------|---|---|---|-----|----------|
| | B | 1 | 2 | 3/A | Tot |
| Living Rm | | 1 | | | 1 |
| Dining Rm | | 1 | | | 1 |
| Kitchen | | 1 | | | 1 |
| Dinette | | | | | |
| 5 Fixt Bath | | | | | |
| 4 Fixt Bath | | | | | |
| 3 Fixt Bath | 1 | | 1 | | 2 |
| 2 Fixt Bath | | | | | |
| Bed Room | | | 3 | | 3 |
| Fam Room | | | | | |
| Den/Other | 3 | | | | 3 |
| Old B: | | | | | 6 |
| Old L: | | | | | 06/30/22 |

| | | | | | |
|-----------------|-----------|------------|----------|-------------|---------|
| Base Cost: | 152232 | CCF: 135 | CLA: 110 | Cost New: | 226065 |
| Phys Depr: | 10.00 (Y) | Func Depr: | | Net Depr: | 90.00 |
| Loc Depr: | | Mkt +: | Mkt-: | Bldg Value: | 203458 |
| Detached Items: | | | | | |
| Land: | 157,800 | Impr: | 203,500 | Total: | 361,300 |

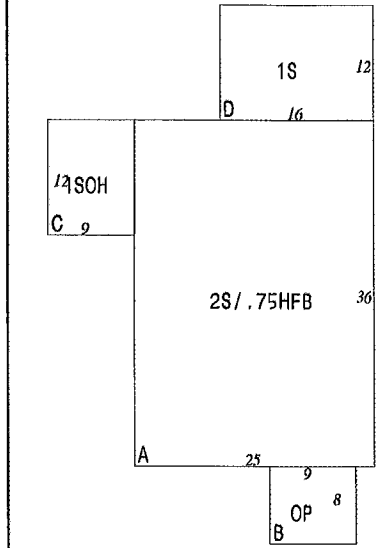

A: 2S/.75HFB U0 R0; U36 R25
 B: OP U0 R14; D8 R9
 C: 1/4 SOH U24 R0; U12 L9
 D: 1S U36 R9; U12 R16
 E:
 F:
 G:
 H:
 I:
 J:
 K:
 L:

900
72
108
192
0
0
0
0

M:
N:
O:
P:

Scale: 20

Block: 4905 Land Desc: 66X184 Owners Name: KEITT, STEPHEN Land: 163,500 Exemption Net Taxable Value Deductions
 Lot: 6 Bldg Desc: 2S-F-0-2UG Street Address: 32 W ENGLEWOOD AVE Bank: 00000 Impr: 183,600 Code: Cd No-Ow
 Qual: Addl Lots: City & State: TEANECK, NJ Zip: 07666 Total: 347,100 Value: 0 347,100
 Card: M (#1 of 1) Acreage: 0.279 Class: 2 Property Loc: 32 W ENGLEWOOD AVE Zone: R01 Map: TEANECK

| SALES HISTORY | | | | | ASSESSMENT HISTORY | | | | BUILDING PERMITS/REMARKS | | | |
|---------------|----------|------------|--------|-----|--------------------|--------|--------|--------|--------------------------|------------------|--------|--------|
| Grantor | Date | Book/Page | Price | Nu# | Year | Land | Impr | Total | Date | Work Description | Amount | Compl. |
| ROVEGNO, PAUL | 07/12/02 | 8506 / 135 | 289900 | | 2021 | 163500 | 183600 | 347100 | | | | |
| | | | | | 2022 | 163500 | 183600 | 347100 | | | | |

| LAND CALCULATIONS | | | | | | | | | | SITE INFORMATION | | | | RESIDENTIAL COST APPROACH | | | | |
|-------------------|----|----|---|----|------|------|-----|------|------|------------------|-------|---------------|------------|---------------------------|--------|----------|-------------|--------------|
| Fr | Rr | SB | T | FF | Avgd | Tabl | EqF | Rate | Site | Cond | Value | Road: | Utilities: | Basement | | | | |
| | | | | | | | | | | | | PAVED | Sewer: YES | BASEMENT | 991 x | 9.520 + | 2160 x1.00 | x1.00= 11594 |
| | | | | | | | | | | | | Curbs: YES | Water: YES | BASEMENT FIN | 744 x | 13.510 + | 1176 x1.00 | x1.00= 11227 |
| | | | | | | | | | | | | Sidewalk: YES | Gas: YES | Main Bldg | | | | |
| | | | | | | | | | | | | Measured: AK | Topo: | FIRST STORY | 1009 x | 49.180 + | 22440 x1.00 | x1.00= 72063 |
| | | | | | | | | | | | | Inspected: N | Neigh: 12 | UPPER STORY | 891 x | 34.910 + | 6732 x1.00 | x1.00= 37837 |
| | | | | | | | | | | | | 03/25/14 | VCS: SF12 | | | | | |

| BUILDING INFORMATION | | | | | | | | | |
|----------------------|----------------|---------------|------------|----------------|------------------|------------------|----------|-----------------|---------------|
| Type and Use: | Class/Quality: | Story Height: | Condition: | Style: | Year Built/EffA: | Exterior Finish: | Windows: | Roof Type: | Livable Area: |
| ONE FAMILY | 16 | | TYPICAL | SMALL COLONIAL | 1920 / 94 (Y) | ALUM/VINYL | | HIP | 1900 SF |
| | | | | | | | | ASPHALT SHINGLE | ESTIMATE |
| | | | | | | | | CONCRETE BLOCK | SHEETROCK |
| Baths: M:1 A:2 O: | | | | | | | | | |
| Kitchens: M:41 A: O: | | | | | | | | | |

| ROOM COUNT | | | | | |
|-------------|---|---|---|-----|----------|
| | B | 1 | 2 | 3/A | Tot |
| Living Rm | | 1 | | | 1 |
| Dining Rm | | 1 | | | 1 |
| Kitchen | | 1 | | | 1 |
| Dinette | | | | | |
| 5 Fixt Bath | | | | | |
| 4 Fixt Bath | | | | | |
| 3 Fixt Bath | 1 | 1 | 1 | | 3 |
| 2 Fixt Bath | | | | | |
| Bed Room | | | 3 | | 3 |
| Fam Room | | 1 | | | 1 |
| Den/Other | 2 | | 1 | | 3 |
| Old B: | | | | | 8 |
| Old L: | | | | | 06/30/22 |

A:OP u0 r0;u6 r32 192
 B:OH u6 r0;u2 r13 26
 C:OH u6 r13;u1 r19 19
 Q:2S/.75HFB u8 r0;u29 r13 d6 r6 u1 r13 d25 l12 u4 l7 818
 E: d3 l13 0
 F:1S/.75HFB u37 r0;u6 r17 d8 r15 d3 l13 d1 l6 u6 l13 173
 G:1SOH u7 r32;u12 e2 s3 d6 s3 w2 18
 H:UPPER/EP u7 r13;u4 r7 28
 I: M:
 J: N:
 K: O:
 L: P:

Block: 4905 Land Desc: 64X184 Owners Name: STEIN, MENACHEM Land: 163,200 Exemption Net Taxable Value Deductions
 Lot: 7 Bldg Desc: 2S-F-0-1UG Street Address: 492 C CEDAR LANE #519 Bank: 00000 Impr: 92,800 Code: Cd No-Ow
 Qual: Addl Lots: City & State: TEANECK, NJ Zip: 07666 Total: 256,000 Value: 0 256,000
 Card: M (#1 of 1) Acreage: 0.270 Class: 2 Property Loc: 26 W ENGLEWOOD AVE Zone: R01 Map: TEANECK

| SALES HISTORY | | | | | ASSESSMENT HISTORY | | | | BUILDING PERMITS/REMARKS | | | |
|--------------------------------|----------|------------|--------|------|--------------------|--------|--------|--------|--------------------------|----------------------------|--------|----------|
| Grantor | Date | Book/Page | Price | Nu# | Year | Land | Impr | Total | Date | Work Description | Amount | Compl. |
| 26 WEST ENGLEWOOD LLC | 03/25/22 | 4697 /1819 | | 1 25 | 2009 | 233200 | 134400 | 367600 | 07/24/07 | CONVERT PORCH TO ONE STORY | 1500 | 07/15/09 |
| KAYLA REAL ESTATE HOLDINGS LLC | 01/21/21 | 4060 /73 | 400000 | | 2017 | 163200 | 92800 | 256000 | | | | |
| KAYLA REAL ESTATE HOLDINGS LLC | 01/20/21 | 4060 /66 | | 1 4 | | | | | | | | |
| FANNIE MAE (FED NAT MTG ASSOC) | 08/19/15 | 2041 /86 | 190000 | 31 | | | | | | | | |

| LAND CALCULATIONS | | | | | | | | | | |
|-------------------|----|----|---|-------|----------|-----|--------|---------|-------------|---------|
| Frnt | Rr | SB | T | FF | AvgdTabl | EqF | Rate | Site | Cond | Value |
| | | | | | | | | | | |
| TRAFFIC | | | | 95 | Units | | Rate | Site | Cond | Value |
| | | | | | 7500 SF | | 7.00 | 105000 | 100 100 100 | 157500 |
| | | | | | 2500 SF | | 5.00 | | 100 100 100 | 12500 |
| | | | | | 1774 SF | | 1.00 | | 100 100 100 | 1774 |
| Net Adj: | | | | 95.00 | SF: | | 11,774 | Auto: Y | Land Value: | 163,185 |

| SITE INFORMATION | |
|------------------|------------|
| Road: | PAVED |
| Curbs: | YES |
| Sidewalk: | YES |
| Measured: | AK |
| Inspected: | N |
| | 03/25/14 |
| Utilities: | Sewer: YES |
| | Water: YES |
| | Gas: YES |
| Topo: | LEVEL |
| Neigh: | 12 |
| VCS: | SF 12 |

| RESIDENTIAL COST APPROACH | |
|---------------------------|--|
| Basement | BASEMENT 832 x 9.520 + 2160 x1.00 x1.00= 10081 |
| Main Bldg | FIRST STORY 1076 x 49.180 +22440 x1.00 x1.00= 75358 |
| | UPPER STORY 928 x 35.170 + 6498 x1.00 x1.00= 39136 |
| Heat/AC | HW BASEBOARD 2004 x 3.310 + 1080 x1.00 x1.00= 7713 |
| Plumbing | 3 FIXTURE BATH 2- 2 x2595.000 + 0 x1.00 x1.00= 0 |
| | 2 FIXTURE BATH 0- 1 x1895.000 + 0 x1.00 x1.00= -1895 |
| Fireplace | FIREPLACE 2STY 1 x4850.000 + 0 x1.00 x1.00= 4850 |
| Attic | |
| Deck/Patio/Garage/Misc | 359400 0 |

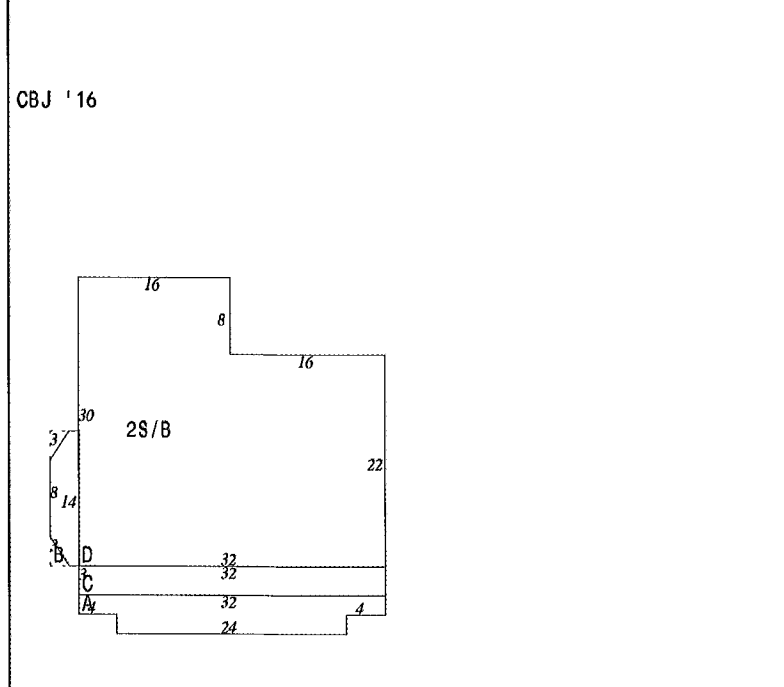

| BUILDING INFORMATION | |
|----------------------|-----------------|
| Type and Use: | ONE FAMILY |
| Class/Quality: | 16 |
| Story Height: | |
| Condition: | FAIR |
| Style: | SMALL COLONIAL |
| Year Built/EffA: | 1912 / 99 (Y) |
| Exterior Finish: | ASBESTOS SIDING |
| Windows: | |
| Roof Type: | GABLE |
| Livable Area: | 2004 SF |
| Roof Material: | ASPHALT SHINGLE |
| Interior Cond: | FAIR |
| Foundation: | CONCRETE BLOCK |
| Interior Wall: | SHEETROCK |
| Baths: | M: A: 2 O: |
| Kitchens: | M: A: O: 1 |

| ROOM COUNT | | | | | |
|-------------|---|---|---|-----|----------|
| | B | 1 | 2 | 3/A | Tot |
| Living Rm | | 1 | | | 1 |
| Dining Rm | | 1 | | | 1 |
| Kitchen | | 1 | | | 1 |
| Dinette | | | | | |
| 5 Fixt Bath | | | | | |
| 4 Fixt Bath | | | | | |
| 3 Fixt Bath | 1 | | 1 | | 2 |
| 2 Fixt Bath | | | | | |
| Bed Room | | | 3 | | 3 |
| Fam Room | 1 | | | | 1 |
| Den/Other | | | | | |
| Old B: | | | | | 6 |
| Old L: | | | | | 06/30/22 |

| | | | | | |
|-----------------|---|------------|----------|-------------|---------|
| Base Cost: | 135243 | CCF: 135 | CLA: 110 | Cost New: | 200836 |
| Phys Depr: | 55.44 (Y) | Func Depr: | | Net Depr: | 44.56 |
| Loc Depr: | | Mkt+: | Mkt-: | Bldg Value: | 89492 |
| Detached Items: | DETACHED GA 216 x 15.910 + 3096 x1.00 x0.37 x1.35= 3263 | | | | |
| Land: | 163,200 | Impr: | 92,800 | Total: | 256,000 |

A: 1S
 B: 1SOH
 C: 2S
 D: 2S/B
 E:
 F:
 G:
 H:
 I:
 J:
 K:
 L:

u2 r3;u2 r32 d2 14 d2 124 u2 14
 u7 r3;11 w2 n3 u8 n3 e2 r1 d14
 u4 r3;u3 r32
 u7 r3;u30 r16 d8 r16,d22 132

112
 36
 96
 832
 0
 0
 0
 0

M:
 N:
 O:
 P:

Scale: 20

Block: 4905 **Land Desc:** 60X185 **Owners Name:** STEIN, MENACHEM **Land:** 221,500 **Exemption:** **Net Taxable Value:** **Deductions:**
Lot: 8 **Bldg Desc:** 2S-F-0-3UG **Street Address:** 492 C CEDAR LANE #519 **Bank:** 00000 **Impr:** 114,400 **Code:** **Cd No-Ow:**
Qual: **Add Lots:** **City & State:** TEANECK, NJ **Zip:** 07666 **Total:** 335,900 **Value:** 0 **335,900**
Card: M (#1 of 1) **Acresage:** 0.255 **Class:** 2 **Property Loc:** 22 W ENGLEWOOD AVE **Zone:** BR **Map:** **TEANECK**

| SALES HISTORY | | | | | ASSESSMENT HISTORY | | | | BUILDING PERMITS/REMARKS | | | |
|-----------------------|----------|-------------|--------|------|--------------------|--------|--------|--------|--------------------------|------------------|--------|--------|
| Grantor | Date | Book/Page | Price | Nu# | Year | Land | Impr | Total | Date | Work Description | Amount | Compl. |
| 22 WEST ENGLEWOOD LLC | 03/25/22 | 4698 /166 | | 1 25 | 2013 | 287000 | 138000 | 425000 | | | | |
| KATZ, ELIE Y ETALS | 01/20/21 | 4068 /1755 | 454000 | | | | | | | | | |
| | 11/17/03 | 8644 /346 | 260000 | | | | | | | | | |
| | 05/18/82 | 06695/00618 | 2828 | | | | | | | | | |

| LAND CALCULATIONS | | | | | | | | | | SITE INFORMATION | | | RESIDENTIAL COST APPROACH | | | | |
|-------------------|----|----|---|----|------|------|-----|------|------|------------------|-------|---------------|---------------------------|--------------|-----------------------------------|--------|--------|
| Frnt | Rr | SB | T | FF | Avgd | Tabl | EqF | Rate | Site | Cond | Value | Road: | Utilities: | Basement | Work Description | Amount | Compl. |
| | | | | | | | | | | | | PAVED | Sewer: YES | BASEMENT | 946 x 9.520 + 2160 x1.00 x1.00= | 11166 | |
| | | | | | | | | | | | | Curbs: YES | Water: YES | Main Bldg | | | |
| | | | | | | | | | | | | Sidewalk: YES | Gas: YES | FIRST STORY | 1021 x 54.382 +25038 x1.00 x1.00= | 80562 | |
| | | | | | | | | | | | | Measured: AK | Topo: LEVEL | UPPER STORY | 694 x 48.180 + 0 x1.00 x1.00= | 33437 | |
| | | | | | | | | | | | | Inspected: Y | Neigh: 52 | Heat/AC | | | |
| | | | | | | | | | | | | 03/25/14 | VCS: SF72 | HW BASEBOARD | 1715 x 3.250 + 1200 x1.00 x1.00= | 6774 | |

TRAFFIC 95 **Units** **Rate** **Site** **Cond** **Value**
 11099 SF 12.00 100000 100 100 100 233188
Net Adj: 95.00 **SF:** 11,099 **Auto:** Y **Land Value:** 221,528
 2ND FLR EST
 STC 10/11/12

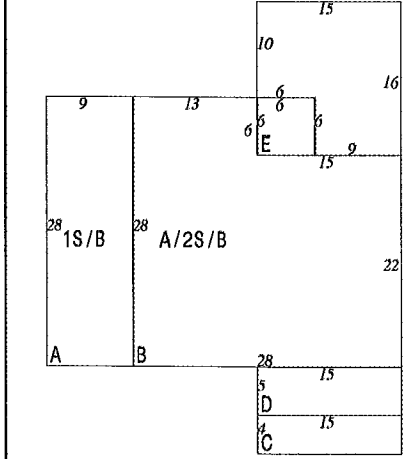

A: 1S/B u9 r0;u28 r9
 B: A/2S/B u9 r9;u28 r13 d6 r15 d22 128
 C: OP u0 r22;u4 r15
 D: 1S u4 r22;u5 r15
 E: WD/CPA u31 r22;u6 r6
 F: CPA u31 r28;u6 l6 u10 r15 d16 19
 G:
 H:
 I:
 J:
 K:
 L:

252
 694
 60
 75
 36
 204
 0
 0

| BUILDING INFORMATION | | | |
|----------------------|-----------------|------------------|---------------|
| Type and Use: | 2 FAMILY | Class/Quality: | 45 |
| Story Height: | | Condition: | FAIR |
| Style: | 2 FAMILY COLONI | Year Built/EffA: | 1910 / 99 (Y) |
| Exterior Finish: | ALUM/VINYL | Windows: | |
| Roof Type: | GABLE | Livable Area: | 1715 SF |
| Roof Material: | ASPHALT SHINGLE | Interior Cond: | TYPICAL |
| Foundation: | CONCRETE BLOCK | Interior Wall: | SHEETROCK |
| Baths: M: | A: 1 | O: 1 | |
| Kitchens: M: | A: 2 | O: | |

| ROOM COUNT | | | | | |
|-------------|---|---|---|-----|----------|
| | B | 1 | 2 | 3/A | Tot |
| Living Rm | | 1 | | | 1 |
| Dining Rm | | 1 | | | 1 |
| Kitchen | | 1 | 1 | | 2 |
| Dinette | | | | | |
| 5 Fixt Bath | | | | | |
| 4 Fixt Bath | | | | | |
| 3 Fixt Bath | | 1 | 1 | | 2 |
| 2 Fixt Bath | | | | | |
| Bed Room | | 2 | 2 | | 4 |
| Fam Room | | | | | |
| Den/Other | | 1 | | | 1 |
| Old B: | | | | | 9 |
| Old L: | | | | | 06/30/22 |

| | | | |
|------------------------|-------------------------------------|---------------------------------|--------------------|
| Plumbing | 3 FIXTURE BATH | 2- 2 x2595.000 + 0 x1.00 x1.00= | 0 |
| Fireplace | | | |
| Attic | UNF DORMER | 9 x 64.500 + 0 x1.00 x1.00= | 581 |
| | UNFIN ATTIC | 694 x 4.255 + 630 x1.00 x1.00= | 3583 |
| Deck/Patio/Garage/Misc | OPEN PORCH | 60 x 10.920 + 437 x1.00 x1.00= | 1092 |
| | DECK | 36 x 5.010 + 200 x1.00 x1.00= | 380 |
| | PATIO | 240 x 5.203 + 203 x1.00 x1.00= | 1452 |
| | 461800 | | 0 |
| Base Cost: | 139027 | CCF: 135 CLA: 100 | Cost New: 187686 |
| Phys Depr: | 44.10 (Y) | Func Depr: | Net Depr: 55.90 |
| Loc Depr: | | Mkt+: Mkt-: | Bldg Value: 104917 |
| Detached Items: | | | |
| DETACHED GA | 960 x 19.860 + 0 x1.00 x0.37 x1.35= | | 9523 |
| Land: | 221,500 | Impr: | 114,400 |
| Total: | | Total: | 335,900 |

Block: 4905 **Land Desc:** 50X180 **Owners Name:** STEIN, MENACHEM **Land:** 197,600 **Exemption:** **Net Taxable Value:** **Deductions:**
Lot: 9 **Bldg Desc:** 2S-F-0-2UG **Street Address:** 492 C CEDAR LANE #519 **Bank:** 00000 **Impr:** 119,200 **Code:** **Cd No-Ow:**
Qual: **Add Lots:** **City & State:** TEANECK, NJ **Zip:** 07666 **Total:** 316,800 **Value:** 0 **316,800**
Card: M (#1 of 1) **Acreage:** 0.207 **Class:** 2 **Property Loc:** 20 W ENGLEWOOD AVE **Zone:** BR **Map:** **TEANECK**

| SALES HISTORY | | | | | ASSESSMENT HISTORY | | | | BUILDING PERMITS/REMARKS | | | |
|------------------------------|----------|-------------|--------|------|--------------------|--------|--------|--------|--------------------------|------------------------|--------|----------|
| Grantor | Date | Book/Page | Price | Nu# | Year | Land | Impr | Total | Date | Work Description | Amount | Compl. |
| 20 WEST ENGLEWOOD LLC | 03/25/22 | 4698 / 140 | | 1 25 | 2013 | 263200 | 136800 | 400000 | 10/05/15 | UPDATE ELECTRICAL/FIRE | 4000 | 00/00/00 |
| KATZ, ELIE & ORLINSKY, HENRY | 01/20/21 | 4065 / 1964 | 454000 | | | | | | | | | |
| | 06/29/01 | 8388 / 244 | | 1 4 | | | | | | | | |

| LAND CALCULATIONS | | | | | | | | | | | |
|-------------------|--------------|------------|--------------|--------------|----------|--------------------|----------------|-------|--------|-------------|--------|
| Fr | Rr | SB | T | FF | Avgd | Tabl | EqF | Rate | Site | Cond | Value |
| TRAFFIC | | | | | 95 | | | | | | |
| | | | | | Units | | | Rate | Site | Cond | Value |
| | | | | | 8999 SF | | | 12.00 | 100000 | 100 100 100 | 207988 |
| Net Adj: | 95.00 | SF: | 8,999 | Auto: | Y | Land Value: | 197,588 | | | | |

| SITE INFORMATION | |
|-----------------------|---|
| Road: PAVED | Utilities: Sewer: YES Water: YES Gas: YES |
| Curbs: YES | Sidewalk: YES |
| Measured: AK | Topo: LEVEL |
| Inspected: Y | Neigh: 52 |
| 03/25/14 | VCS: SF72 |

| RESIDENTIAL COST APPROACH | |
|---|---|
| Basement BASEMENT | 792 x 9.630 + 2072 x1.00 x1.00= 9699 |
| Main Bldg FIRST STORY UPPER STORY | 932 x 54.500 +24920 x1.00 x1.00= 75714 616 x 48.180 + 0 x1.00 x1.00= 29679 |
| Heat/AC HW BASEBOARD | 1548 x 3.250 + 1200 x1.00 x1.00= 6231 |
| Plumbing 3 FIXTURE BATH | 2- 2 x2595.000 + 0 x1.00 x1.00= 0 |
| Fireplace | |
| Attic DORMER FIN ATTIC UNFIN ATTIC | 6 x 136.000 + 0 x1.00 x1.00= 816 554 x 8.310 + 1380 x1.00 x1.00= 5984 62 x 7.355 + 0 x1.00 x1.00= 456 |
| Deck/Patio/Garage/Misc ENCLOSED PORCH DECK 428500 | 64 x 26.840 + 1092 x1.00 x1.00= 2810 180 x 5.310 + 182 x1.00 x1.00= 1138 0 |

| BUILDING INFORMATION | |
|--|--|
| Type and Use: 2 FAMILY | Class/Quality: 45 |
| Story Height: | Condition: TYPICAL |
| Style: 2 FAMILY COLONI | Year Built/EffA: 1930 / 84 (Y) |
| Exterior Finish: ALUM/VINYL | Windows: |
| Roof Type: GABLE | Livable Area: 1548 SF |
| Roof Material: ASPHALT SHINGLE | Interior Cond: TYPICAL |
| Foundation: CONCRETE BLOCK | Interior Wall: SHEETROCK |
| Baths: M: A: 1 O: 1 | |
| Kitchens: M: A: 2 O: | |

| ROOM COUNT | | | | | |
|-------------|---|---|---|-----|----------|
| | B | 1 | 2 | 3/A | Tot |
| Living Rm | | 1 | 1 | | 2 |
| Dining Rm | | | | | |
| Kitchen | | 1 | 1 | | 2 |
| Dinette | | | | | |
| 5 Fixt Bath | | | | | |
| 4 Fixt Bath | | | | | |
| 3 Fixt Bath | | 1 | 1 | | 2 |
| 2 Fixt Bath | | | | | |
| Bed Room | | 2 | 1 | | 3 |
| Fam Room | | | | | |
| Den/Other | | 1 | | 1 | 2 |
| Old B: | | | | | 9 |
| Old L: | | | | | 06/30/22 |

| | | | |
|-----------------------------|--|-----------------|---------------------------|
| Base Cost: 132527 | CCF: 135 | CLA: 100 | Cost New: 178911 |
| Phys Depr: 36.75 (Y) | Func Depr: | | Net Depr: 63.25 |
| Loc Depr: | Mkt+: | Mkt-: | Bldg Value: 113161 |
| Detached Items: | | | |
| DETACHED GA | 520 x 15.780 + 3180 x1.00 x0.39 x1.35= | | 5995 |
| Land: 197,600 | Impr: 119,200 | Total: | 316,800 |

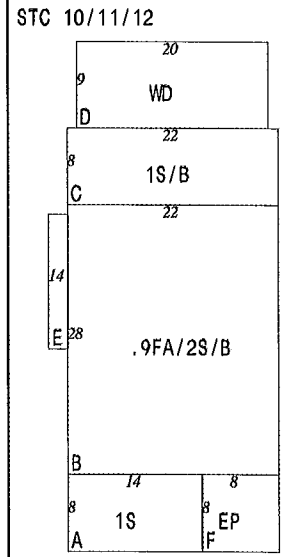

A: 1S u0 r2;u8 r14
B: .9FA/2S/B u8 r2;u28 r22
C: 1S/B u36 r2;u8 r22
D: WD u44 r3;u9 r20
E: 1SOH u21 r0;u14 r2
F: EP u0 r16;u8 r8
G:
H:
I:
J:
K:
L:

112
616
176
180
28
64
0
0

M:
N:
O:
P:

Scale: 20

Block: 4905 Land Desc: 55X120 Owners Name: ALVARADO, ANA ETAL Land: 170,200 Exemption Net Taxable Value Deductions
 Lot: 10 Bldg Desc: 2S-AL-0-2UG Street Address: 18 W ENGLEWOOD AVENUE Bank: 00000 Impr: 174,900 Code: Cd No-Ow
 Qual: Addl Lots: City & State: TEANECK, NJ Zip: 07666 Total: 345,100 Value: 0 345,100
 Card: M (#1 of 1) Acreage: 0.152 Class: 2 Property Loc: 18 W ENGLEWOOD AVE Zone: BR Map: TEANECK

| SALES HISTORY | | | | |
|-----------------------|----------|-------------|--------|------|
| Grantor | Date | Book/Page | Price | Nu# |
| PAVON, ELDANYDIA EXRX | 12/16/20 | 3979 / 559 | 385000 | 7 |
| | 02/11/09 | 139 / 2096 | | 1 14 |
| | 10/22/04 | 08754/00472 | | 1 1 |
| | 08/27/01 | 08417/00663 | 215000 | |

| ASSESSMENT HISTORY | | | |
|--------------------|--------|--------|--------|
| Year | Land | Impr | Total |
| 2021 | 170200 | 174900 | 345100 |
| 2022 | 170200 | 174900 | 345100 |

| BUILDING PERMITS/REMARKS | | | |
|--------------------------|------------------------------|--------|----------|
| Date | Work Description | Amount | Compl. |
| 12/06/04 | BASEMENT/BATHROOM RENOVATION | 6200 | 06/20/05 |

| LAND CALCULATIONS | | | | | | | | | | | |
|-------------------|----|----|---|----|---------|------|-------|-------|--------|-------------|---------|
| Prt | Rr | SB | T | FF | Avgd | Tabl | EqF | Rate | Site | Cond | Value |
| | | | | | | | | | | | |
| TRAFFIC | | | | | 95 | | | | | | |
| | | | | | Units | | | Rate | Site | Cond | Value |
| | | | | | 6599 SF | | | 12.00 | 100000 | 100 100 100 | 179188 |
| Net Adj: | | | | | 95.00 | SF: | 6,599 | Auto: | Y | Land Value: | 170,228 |

| SITE INFORMATION | |
|------------------|-------------|
| Road: | Utilities: |
| PAVED | Sewer: YES |
| Curbs: YES | Water: YES |
| Sidewalk: YES | Gas: YES |
| Measured: AK | Topo: LEVEL |
| Inspected: Y | Neigh: 52 |
| 03/25/14 | VCS: SF72 |

| RESIDENTIAL COST APPROACH | | | |
|---------------------------|-------|----------------------|--------------|
| Basement | | | |
| BASEMENT | 742 x | 9.630 + 2072 x1.00 | x1.00= 9217 |
| BASEMENT FIN | 519 x | 13.550 + 1170 x1.00 | x1.00= 8202 |
| Main Bldg | | | |
| FIRST STORY | 898 x | 49.100 + 22491 x1.00 | x1.00= 66583 |
| UPPER STORY | 688 x | 34.920 + 6734 x1.00 | x1.00= 30759 |

BSMT LOCKED WENT OFF OLD

| BUILDING INFORMATION | |
|----------------------|------------------|
| Type and Use: | Class/Quality: |
| ONE FAMILY | 16 |
| Story Height: | Condition: |
| | UPDATES |
| Style: | Year Built/EffA: |
| SMALL COLONIAL | 1936 / 78 (Y) |
| Exterior Finish: | Windows: |
| ALUM/VINYL | |

| | | | |
|-----------------|------------------|--------------------|--------------|
| Heat/AC | | | |
| HOT WATER OR ST | 2105 x | 3.830 + 1440 x1.00 | x1.00= 9502 |
| Plumbing | | | |
| 3 FIXTURE BATH | 3- 2 x2595.000 + | 0 x1.00 | x1.00= 2595 |
| 2 FIXTURE BATH | 0- 1 x1895.000 + | 0 x1.00 | x1.00= -1895 |

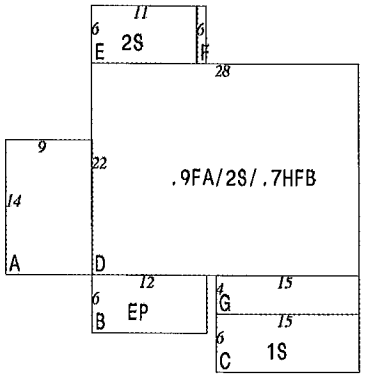

A: 1S/.7HFB u10 r0;u14 r9
 B: EP u4 r9;u6 r12
 C: 1S u0 r22;u6 r15
 D: .9FA/2S/.7HFB u10 r9;u22 r28
 E: 2S u32 r9;u6 r11
 F: OH u32 r20;u6 r1
 G: EP u6 r22;u4 r15
 H:
 I:
 J:
 K:
 L:

M:
 N:
 O:
 P:

126
 72
 90
 616
 66
 6
 60
 0

| | |
|-----------------------|----------------|
| Roof Type: | Livable Area: |
| GABLE | 1586 SF |
| Roof Material: | Interior Cond: |
| ASPHALT SHINGLE | UPDATES |
| Foundation: | Interior Wall: |
| CONCRETE BLOCK | SHEETROCK |
| Baths: M: 1 A: 2 O: | |
| Kitchens: M: 31 A: O: | |

| | | | |
|------------------------|---------------|---------------------|---------------------|
| Fireplace | | | |
| FIREPLACE 2STY | 1 x4850.000 + | 0 x1.00 | x1.00= 4850 |
| Attic | | | |
| DORMER | 8 x | 136.000 + | 0 x1.00 x1.00= 1088 |
| FIN ATTIC | 554 x | 8.310 + 1380 x1.00 | x1.00= 5984 |
| UNFIN ATTIC | 62 x | 7.355 + | 0 x1.00 x1.00= 456 |
| Deck/Patio/Garage/Misc | | | |
| ENCLOSED PORCH | 132 x | 26.990 + 1092 x1.00 | x1.00= 4655 |
| 427500 | | | 0 |

| ROOM COUNT | | | | | |
|-------------|---|---|---|-----|----------|
| | B | 1 | 2 | 3/A | Tot |
| Living Rm | | 1 | | | 1 |
| Dining Rm | | 1 | | | 1 |
| Kitchen | | 1 | | | 1 |
| Dinette | | | | | |
| 5 Fixt Bath | | | | | |
| 4 Fixt Bath | | | | | |
| 3 Fixt Bath | 1 | 1 | 1 | | 3 |
| 2 Fixt Bath | | | | | |
| Bed Room | 2 | | 4 | | 6 |
| Fam Room | | | | | |
| Den/Other | 1 | 1 | | 1 | 3 |
| Old B: | | | | | 9 |
| Old L: | | | | | 06/30/22 |

| | | | | | |
|-----------------|-----------|---------------------|--------------|-------------|---------|
| Base Cost: | 141996 | CCF: 135 | CLA: 110 | Cost New: | 210864 |
| Phys Depr: | 19.15 (Y) | Func Depr: | | Net Depr: | 80.85 |
| Loc Depr: | | Mkt+: Mkt-: | | Bldg Value: | 170479 |
| Detached Items: | | | | | |
| DETACHED GA | 360 x | 15.950 + 3084 x1.00 | x0.37 x1.35= | 4409 | |
| Land: | 170,200 | Impr: | 174,900 | Total: | 345,100 |

Block: 4905 **Land Desc:** .0184 **Owners Name:** JUNG, JOOHO & LEE, CHONG IM **Land:** 59,600 **Exemption:** **Net Taxable Value:** **Deductions:**
Lot: 11 **Bldg Desc:** CONDO **Street Address:** 1360 TEANECK RD **Bank:** 00000 **Impr:** 218,200 **Code:** **Cd No-Ow:**
Qual: C0001 **Add Lots:** **City & State:** TEANECK, NJ **Zip:** 07666 **Total:** 277,800 **Value:** 0 277,800
Card: M (#1 of 1) **Acreage:** 0.018 **Class:** 4A **Property Loc:** 1360 TEANECK ROAD **Zone:** BR **Map:** **TEANECK**

| SALES HISTORY | | | | | | | | | | | ASSESSMENT HISTORY | | | | BUILDING PERMITS/REMARKS | | | |
|--------------------------------|----|----------|-----------|--------|------|------|-------|--------|--------|------|-----------------------------------|----------------------|-----------------|------------------|---------------------------|------------------------|--|--|
| Grantor | | Date | Book/Page | Price | Nu# | Year | Land | Impr | Total | Date | Work Description | Amount | Compl. | | | | | |
| DENATA BUSINESS CONDOMINIUM CO | | 02/12/02 | 8452 /576 | 161000 | | 2021 | 59600 | 218200 | 277800 | | | | | | | | | |
| | | | | | | 2022 | 59600 | 218200 | 277800 | | | | | | | | | |
| LAND CALCULATIONS | | | | | | | | | | | SITE INFORMATION | | | | RESIDENTIAL COST APPROACH | | | |
| Frnt | Rr | SB | T | FF | Avgd | Tabl | EqF | Rate | Site | Cond | Value | Road: | | Utilities: | | Basement | | |
| | | | | | | | | | | | | Curbs: | | Sewer: | | Main Bldg | | |
| | | | | | | | | | | | | Sidewalk: | | Water: | | | | |
| | | | | | | | | | | | | Measured: | | Gas: | | | | |
| | | | | | | | | | | | | Inspected: | | Neigh: 52 | | | | |
| | | | | | | | | | | | | | | VCS: SF52 | | | | |
| | | | | | | | | | | | | BUILDING INFORMATION | | | | | | |
| | | | | | | | | | | | | Type and Use: | | Class/Quality: | | Heat/AC | | |
| | | | | | | | | | | | | Story Height: | | Condition: | | Plumbing | | |
| | | | | | | | | | | | | Style: | | Year Built/EffA: | | | | |
| | | | | | | | | | | | | Exterior Finish: | | Windows: | | | | |
| | | | | | | | | | | | | Roof Type: | | Livable Area: | | Fireplace | | |
| | | | | | | | | | | | | Roof Material: | | Interior Cond: | | Attic | | |
| | | | | | | | | | | | | Foundation: | | Interior Wall: | | Deck/Patio/Garage/Misc | | |
| | | | | | | | | | | | | Baths: M: A: O: | | | | | | |
| | | | | | | | | | | | | Kitchens: M: A: O: | | | | | | |
| | | | | | | | | | | | | ROOM COUNT | | | | | | |
| | | | | | | | | | | | | B | 1 | 2 | 3/A | Tot | | |
| | | | | | | | | | | | | Living Rm | | | | | | |
| | | | | | | | | | | | | Dining Rm | | | | | | |
| | | | | | | | | | | | | Kitchen | | | | | | |
| | | | | | | | | | | | | Dinette | | | | | | |
| | | | | | | | | | | | | 5 Fixt Bath | | | | | | |
| | | | | | | | | | | | | 4 Fixt Bath | | | | | | |
| | | | | | | | | | | | | 3 Fixt Bath | | | | | | |
| | | | | | | | | | | | | 2 Fixt Bath | | | | | | |
| | | | | | | | | | | | | Bed Room | | | | | | |
| | | | | | | | | | | | | Fam Room | | | | | | |
| | | | | | | | | | | | | Den/Other | | | | | | |
| | | | | | | | | | | | | Old B: | | | 0 | | | |
| | | | | | | | | | | | | Old L: | | | 07/06/22 | | | |
| | | | | | | | | | | | Base Cost: 0 | | CCF: 135 CLA: 0 | | Cost New: 0 | | | |
| | | | | | | | | | | | Phys Depr: 35.00 (Y) | | Func Depr: | | Net Depr: 65.00 | | | |
| | | | | | | | | | | | Loc Depr: | | Mkt+: Mkt: | | Bldg Value: 0 | | | |
| | | | | | | | | | | | Detached Items: | | | | | | | |
| | | | | | | | | | | | RETAIL CONDO: 1,425 SF @ \$195/SF | | | | 218,200 | | | |
| | | | | | | | | | | | Land: 59,600 | | Impr: 218,200 | | Total: 277,800 | | | |

A:
B:
C:
D:
E:
F:
G:
H:
I:
J:
K:
L:

M:
N:
O:
P:

0
0
0
0
0
0
0
0
0

Block: 4905 **Land Desc:** .0204 **Owners Name:** JOOHO JUNG & CHONG IM LEE **Land:** 60,700 **Exemption** **Net Taxable Value** **Deductions**
Lot: 11 **Bldg Desc:** CONDO **Street Address:** 1360 TEANECK RD **Bank:** **Impr:** 41,800 **Code:** **Cd No-Ow**
Qual: C0002 **Add Lots:** **City & State:** TEANECK, NJ **Zip:** 07666 **Total:** 102,500 **Value:** 0 102,500
Card: M (#1 of 1) **Acreage:** 0.020 **Class:** 4A **Property Loc:** 1362 TEANECK RD **Zone:** BR **Map:** **TEANECK**

| SALES HISTORY | | | | | | | | | | ASSESSMENT HISTORY | | | | BUILDING PERMITS/REMARKS | | | | |
|---------------------------------|----------|-----------|--------|-----|------------------|--------------|-------|--------|------|------------------------|------------------|--------|------------|---|-----------|----------|-----------|--|
| Grantor | Date | Book/Page | Price | Nu# | Year | Land | Impr | Total | | Date | Work Description | Amount | Compl. | | | | | |
| DENATA BUSINESS CONDOS, C/O ADL | 02/12/02 | 8452 /576 | 161000 | | 2021 | 60700 | 41800 | 102500 | | | | | | | | | | |
| | | | | | 2022 | 60700 | 41800 | 102500 | | | | | | | | | | |
| LAND CALCULATIONS | | | | | | | | | | SITE INFORMATION | | | | RESIDENTIAL COST APPROACH | | | | |
| Frnt | Rr | SB | T | FF | Avgd | Tabl | EqF | Rate | Site | Cond | Value | Road: | | Utilities: | | Basement | | |
| | | | | | | | | | | | | | Sewer: | | Water: | | Main Bldg | |
| | | | | | | | | | | | | | Gas: | | Topo: | | | |
| | | | | | | | | | | | | | Inspected: | | Neigh: 52 | | | |
| | | | | | | | | | | | | | VCS: SF52 | | | | | |
| BUILDING INFORMATION | | | | | | | | | | | | | | | | | | |
| Type and Use: | | | | | Class/Quality: | | | | | Heat/AC | | | | | | | | |
| Story Height: | | | | | Condition: | | | | | Plumbing | | | | | | | | |
| Style: | | | | | Year Built/EffA: | | | | | Fireplace | | | | | | | | |
| Exterior Finish: | | | | | Windows: | | | | | Attic | | | | | | | | |
| Roof Type: | | | | | Livable Area: | | | | | Deck/Patio/Garage/Misc | | | | | | | | |
| Roof Material: | | | | | Interior Cond: | | | | | | | | | | | | | |
| Foundation: | | | | | Interior Wall: | | | | | | | | | | | | | |
| Baths: M: | | A: | | O: | | Kitchens: M: | | A: | | O: | | | | | | | | |
| ROOM COUNT | | | | | | | | | | | | | | | | | | |
| | | | | | | B | 1 | 2 | 3/A | Tot | | | | | | | | |
| Living Rm | | | | | | | | | | | | | | | | | | |
| Dining Rm | | | | | | | | | | | | | | | | | | |
| Kitchen | | | | | | | | | | | | | | | | | | |
| Dinette | | | | | | | | | | | | | | | | | | |
| 5 Fixt Bath | | | | | | | | | | | | | | Base Cost: 0 CCF: 135 CLA: 0 Cost New: 0 | | | | |
| 4 Fixt Bath | | | | | | | | | | | | | | Phys Depr: 35.00 (Y) Func Depr: Net Depr: 65.00 | | | | |
| 3 Fixt Bath | | | | | | | | | | | | | | Loc Depr: Mkt+: Mkt-: Bldg Value: 0 | | | | |
| 2 Fixt Bath | | | | | | | | | | | | | | Detached Items: | | | | |
| Bed Room | | | | | | | | | | | | | | RETAIL CONDO: 500 SF @ \$205/SF 41,800 | | | | |
| Fam Room | | | | | | | | | | | | | | | | | | |
| Den/Other | | | | | | | | | | | | | | | | | | |
| Old B: | | | | | | | | | | 0 | | | | Land: 60,700 Impr: 41,800 Total: 102,500 | | | | |
| Old L: | | | | | | | | | | 07/06/22 | | | | | | | | |

A:
B:
C:
D:
E:
F:
G:
H:
I:
J:
K:
L:

M:
N:
O:
P:

0
0
0
0
0
0
0

Block: 4905 Land Desc: 66X68 Owners Name: WEL MANAGED RLTY & LEVIE, WARREN Land: 237,800 Exemption Net Taxable Value Deductions
 Lot: 12 Bldg Desc: 1S-B-A Street Address: P.O. BOX 149 Bank: 00000 Impr: 430,200 Code: Cd No-Ow
 Qual: Addl Lots: City & State: TEANECK, NJ Zip: 07666 0149 Total: 668,000 Value: 0 668,000
 Card: M (#1 of 1) Acreage: 0.103 Class: 4A Property Loc: 1354-1358 TEANECK RD Zone: BR Map: TEANECK

| SALES HISTORY | | | | | | | | | | ASSESSMENT HISTORY | | | | BUILDING PERMITS/REMARKS | | | | | |
|-------------------|----------|-----------|--------|-----|------|--------|--------|--------|----------|-----------------------|--------|------------|---|-----------------------------------|-----|-------------------------------------|--|--|--|
| Grantor | Date | Book/Page | Price | Nu# | Year | Land | Impr | Total | Date | Work Description | Amount | Compl. | | | | | | | |
| | 05/27/99 | 8174 /944 | 410000 | | 2021 | 237800 | 430200 | 668000 | 06/04/04 | INTERATION ALYERATION | 3230 | 00/00/00 | | | | | | | |
| | | | | | 2022 | 237800 | 430200 | 668000 | | | | | | | | | | | |
| LAND CALCULATIONS | | | | | | | | | | SITE INFORMATION | | | | RESIDENTIAL COST APPROACH | | | | | |
| Frnt | Rr | SB | T | FF | Avgd | Tabl | EqF | Rate | Site | Cond | Value | Road: | | Utilities: | | Basement | | | |
| | | | | | | | | | | | | Curbs: | | Sewer: | | | | | |
| | | | | | | | | | | | | Sidewalk: | | Water: | | Main Bldg | | | |
| | | | | | | | | | | | | Measured: | | Gas: | | | | | |
| | | | | | | | | | | | | Inspected: | | Neigh: 52 | | Heat/AC | | | |
| | | | | | | | | | | | | | | VCS: SF52 | | | | | |
| | | | | | | | | | | BUILDING INFORMATION | | | | | | | | | |
| | | | | | | | | | | Type and Use: | | | | Class/Quality: | | | | | |
| | | | | | | | | | | Story Height: | | | | Condition: | | | | | |
| | | | | | | | | | | Style: | | | | Year Built/EffA: 0000 / 99 (Y) | | | | | |
| | | | | | | | | | | Exterior Finish: | | | | Windows: | | | | | |
| | | | | | | | | | | Roof Type: | | | | Livable Area: 0 SF | | | | | |
| | | | | | | | | | | Roof Material: | | | | Interior Cond: | | | | | |
| | | | | | | | | | | Foundation: | | | | Interior Wall: | | | | | |
| | | | | | | | | | | Baths: M: A: O: | | | | | | | | | |
| | | | | | | | | | | Kitchens: M: A: O: | | | | | | | | | |
| | | | | | | | | | | ROOM COUNT | | | | | | | | | |
| | | | | | | | | | | | B | 1 | 2 | 3/A | Tot | | | | |
| | | | | | | | | | | Living Rm | | | | | | Base Cost: 0 | | | |
| | | | | | | | | | | Dining Rm | | | | | | Phys Depr: 35.00 (Y) | | | |
| | | | | | | | | | | Kitchen | | | | | | Loc Depr: 0 | | | |
| | | | | | | | | | | Dinette | | | | | | CCF: 135 CLA: 0 | | | |
| | | | | | | | | | | 5 Fixt Bath | | | | | | Func Depr: 65.00 | | | |
| | | | | | | | | | | 4 Fixt Bath | | | | | | Mkt+: Mkt-: Bldg Value: 0 | | | |
| | | | | | | | | | | 3 Fixt Bath | | | | | | Detached Items: | | | |
| | | | | | | | | | | 2 Fixt Bath | | | | | | RETAIL: 5,808 SF @ \$115\SF 430,200 | | | |
| | | | | | | | | | | Bed Room | | | | | | | | | |
| | | | | | | | | | | Fam Room | | | | | | | | | |
| | | | | | | | | | | Den/Other | | | | | | | | | |
| | | | | | | | | | | Old B: | | | | | | Land: 237,800 | | | |
| | | | | | | | | | | Old L: | | | | | | Impr: 430,200 | | | |
| | | | | | | | | | | | | | | | | Total: 668,000 | | | |
| | | | | | | | | | | | | | | | | 07/06/22 | | | |

A:
B:
C:
D:
E:
F:
G:
H:
I:
J:
K:
L:

0
0
0
0
0
0
0
0

M:
N:
O:
P:

457 92

TOWNSHIP OF TEANECK

| | | | |
|-------------------|------|------|-----|
| BLOCK | 4905 | LOT | 12 |
| CLASS | 4A | ZONE | OBP |
| BLDG. DESCRIPTION | 1SB | | |

Address 1350-1360 Teaneck Road

| OWNER OF RECORD | SRI-A SERIAL NUMBER | DATE OF TRANSFER | SALES PRICE | SALES RATIO | USABLE | NON-USABLE | ASSESSMENT SUMMARY | | | | | | |
|-------------------|---------------------|------------------|-------------|-------------|--------|------------|--------------------|-----------|--------|-----------|------|-------|------|
| | | | | | | | LAND | BUILDINGS | Exempt | DEDUCTION | | TOTAL | YEAR |
| | | | | | | | | | | VET. | S.C. | | |
| Peraino, Guiseppe | | | | | | | | | | | | 19 | |
| | | | | | | | | | | | | 19 | |
| | | | | | | | | | | | | 19 | |
| | | | | | | | | | | | | 19 | |
| | | | | | | | | | | | | 19 | |
| | | | | | | | | | | | | 19 | |
| | | | | | | | | | | | | 19 | |
| | | | | | | | | | | | | 19 | |
| | | | | | | | | | | | | 19 | |
| | | | | | | | | | | | | 19 | |
| | | | | | | | | | | | | 19 | |
| | | | | | | | | | | | | 19 | |
| | | | | | | | | | | | | 19 | |
| | | | | | | | | | | | | 19 | |
| | | | | | | | | | | | | 19 | |
| | | | | | | | | | | | | 19 | |
| | | | | | | | | | | | | 19 | |
| | | | | | | | | | | | | 19 | |
| | | | | | | | | | | | | 19 | |
| | | | | | | | | | | | | 19 | |

APPEAL DATA

| PERMITS AND DESCRIPTION | COMPLETION DATA | 19 | 19 | 19 | 19 | 19 | 19 | |
|-------------------------|-----------------|----------|---------|----|----|----|----|--|
| | | Appeal | Granted | | | | | |
| | | Denied | | | | | | |
| Value Change | | Land | County | | | | | |
| | | | State | | | | | |
| | | Building | County | | | | | |
| | | | State | | | | | |

LAND VALUE COMPUTATIONS

| FRONTAGE | EFFECTIVE FRONTAGE | AVERAGE DEPTH | BASE UNIT PRICE | DEPTH FACTOR | ADJUSTED UNIT PRICE | TOTAL | SIZE, SHAPE LOCATION ADJUSTMENT | VALUE |
|-------------------------|--------------------|---------------|-----------------|--------------|---------------------|-------|---------------------------------|--------|
| 66 | 66 | 68 | 250 | 84 | 554 | 19406 | - | 19400 |
| | | | 400 | | 336 | | | 22,176 |
| No. of Acres or Sq. Ft. | | | Unit Price | | | | | |

ZONING LAND RECORD

| ZONING | LAND RECORD | | | | TOTAL VALUE LAND | TOTAL VALUE BUILDINGS | TOTAL VALUE LAND & BLDGS. |
|------------------|---|---|---|--|------------------|-----------------------|---------------------------|
| 1 Fam. Residence | Sewer | <input checked="" type="checkbox"/> No Street | High | | 22,200 | | 19400 |
| Garden Apts. | Water | <input checked="" type="checkbox"/> Dirt Street | Low | | | | |
| Bus./Off./Prof. | <input checked="" type="checkbox"/> Gas | <input checked="" type="checkbox"/> Conc. Paved | Level | | | 27700 | |
| Business | Elec. | <input checked="" type="checkbox"/> Asphalt Paved | <input checked="" type="checkbox"/> Rolling | | | | |
| Light Industry | Curbs | <input checked="" type="checkbox"/> | | | | | 47100 |
| University | Sidewalks | <input checked="" type="checkbox"/> | | | | | |

| | | | | | | | | |
|-------------|------------|--------|------|------|------|----|-------|-------|
| Gas Station | Theater | 15B #3 | 20.3 | 19.1 | 1027 | 45 | 33702 | 47100 |
| Offices | Hotel | | | | | | | |
| Stores | Bank | | | | | | | |
| Apartments | Warehouse | | | | | | | |
| Garage | Industrial | | | | | | | |

4905/12
INSPECTOR 309
INSPECTION DATES

STORIES: 1 1/2 2 2 1/2 3 4 5
Date Meas. Date Listed Priced Checked TOTAL

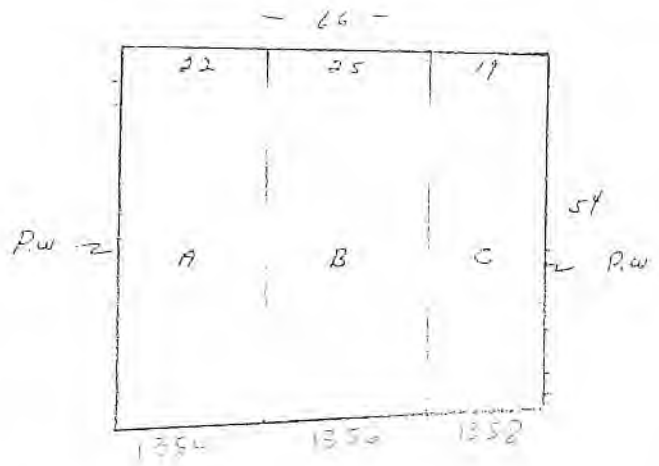

Ground Area 3729 Sq. Ft. Perimeter 194 W.R. #1.3
Height 12/8 Ft.

Notes:
Rental Details: A. SILVA LEE BLDG 2017 225
B. HED INC Liquid
C. ...

| Bldg. Ident. | Class No. | DIMENSION | | Area | Founda-tion | Floor | Roof | Walls | Unit Cost | Replac-ment cost | Cost Con- version Factor | Total Replac- ment Cost |
|--------------|-----------|-----------|-------|------|-------------|-------|------|-------|-----------|------------------|--------------------------|-------------------------|
| | | Width | Depth | | | | | | | | | |
| | | | | | | | | | | | | |
| | | | | | | | | | | | | |
| | | | | | | | | | | | | |
| | | | | | | | | | | | | |

| STRUCTURAL FRAME | | FLOORS - 4 B | | | | ELECTRIC WIRING - 7 | | |
|---|-----------|--------------|------------------|---|---|---------------------|---|--|
| COLUMNS | WOODSTEEL | CONC | CONC ON GRADE | 1 | 2 | 3 | 4 | KNOB & TUBE OR ROMEX |
| MAIN BEAMS | | | REIN. CONC. | | | | | BX |
| JOISTS | | | WOOD | | | | | CONDUIT |
| TRUSSES | | | CONC. ON MTL K | | | | | POWER WIRING |
| GIRDERS | | | FINISH | | | | | LIGHTING FIXTURES |
| FIREPROOF CONSTR. | | | RUBBER TILE | | | | | FLUORESCENT |
| FOUNDATION - 1 | | | ASPHALT TILE | | | | | INCANDESCENT |
| CONC WALLS | | | VINYL ASB. TILE | | | | | HEATING - 8 |
| CONC BLOCK WALLS | | | HARDWOOD | | | | | STEAM |
| BRICK WALLS | | | SOFTWOOD | | | | | HOT WATER |
| STONE WALLS | | | CERAMIC TILE | | | | | FORCED AIR |
| CONC PIERS | | | TERRAZZO | | | | | WARM AIR GRAVITY |
| BEARING PILES | | | INT. FINISH - 5 | | | | | UNIT HEATERS |
| EXTERIOR WALLS - 2 | | | PARTITION | | | | | PIPELESS |
| REINFORCED CONC | | | HARDWOOD PNL. | | | | | BASEBOARD ELECTRIC |
| CONCRETE BLOCK | | | L & P ON STUDS | | | | | CEILING RADIANT ELEC. |
| ST ON CB OR TILE | | | DRY WALL | | | | | FLOOR RADIANT ELEC. |
| STUCCO ON FRAME | | | PLAS. ON MSNRY. | | | | | FLOOR RADIANT H. W. |
| COMM BRK ON FRAME | | | PAINTED BLOCK | | | | | NO HEATING |
| COMM BRK ON CB OR TILE | | | MARBLE | | | | | AUTOMATIC UNIT CONV |
| FACE BRK ON FRAME | | | GLZ. WALL TILE | | | | | OIL |
| FACE BRK ON CB OR TILE | | | METAL | | | | | GAS |
| FACE BRK ON COMM BRK | | | UNFINISHED | | | | | STOKER |
| SIDING ON SHEATHING | | | | | | | | |
| ALUMINUM SIDING | | | CEILING | | | | | BASEMENT AREA - 9 |
| WOOD SHINGLE SIDING | | | PLASTER | | | | | NONE <input type="checkbox"/> FULL <input checked="" type="checkbox"/> |
| GLAZED BLK ON CB | | | DRY WALL | | | | | PART <input type="checkbox"/> SO. FT. |
| GLAZED BRK ON CB | | | ACOUSTIC | | | | | DIRT <input type="checkbox"/> WOOD <input type="checkbox"/> CONC. |
| PORCE. ENAM. STEEL | | | METAL | | | | | FINISHED <input type="checkbox"/> % |
| CUT STONE FACING | | | SUSPENDED | | | | | OFFICE <input type="checkbox"/> SO. FT. |
| TERRA COTTA FACING | | | | | | | | APARTMENT <input type="checkbox"/> SO. FT. |
| | | | TILING | | | | | GARAGE <input type="checkbox"/> SO. FT. |
| PARTY WALLS | | | BATH FL & WSC | | | | | AIR CONDITIONING - 10 |
| SASH | | | BATH FL & WLS. | | | | | WASHED <input type="checkbox"/> REFRIG. <input type="checkbox"/> |
| WOOD <input type="checkbox"/> STEEL <input type="checkbox"/> ALUM. | | | T. RM FL & WSC | | | | | NUMBER OF FLOORS |
| STORE FRONT L/E | | | T. RM FL & WLS. | | | | | FLOOR AREA <input type="checkbox"/> SO. FT. |
| WOOD <input type="checkbox"/> METAL | | | T. RM FL ONLY | | | | | CENTRAL SYSTEM |
| FAIR <input type="checkbox"/> AVG. <input checked="" type="checkbox"/> GOOD | | | ST SHOWER | | | | | FIRE PROTECTION - 11 |
| ROOF - 3 | | | KITCHEN FL. | | | | | SPRINKLER SYSTEM |
| WOOD | | | KITCHEN WSC | | | | | EXPOSED <input type="checkbox"/> CONCEALED |
| REINFORCED CONCRETE | | | | | | | | NUMBER OF FLOORS |
| STEEL DECK | | | | | | | | FLOOR AREA <input type="checkbox"/> SO. FT. |
| COVER: | | | PLUMBING - 6 | | | | | ELEVATORS - 12 A/D |
| ASPHALT SHINGLE | | | 3 FIX BATH RM | | | | | TYPE |
| ASPHALT ROLL | | | 2 FIX BATH RM | | | | | PASS. |
| BUILT-UP T & G | | | 2 FIX TOILET RM | | | | | STOPS |
| CORRUGATED METAL | | | 3 FIX ST SH BATH | | | | | FREIGHT |
| | | | ST SHOWER | | | | | ATTENDED |
| | | | OPEN SHOWER HDS | | | | | PASS. OPERATED |
| INSULATION | | | WATER CLOSET | | | | | DUMB WAITER |
| ROOFING OR CEILING | | | LAVATORIES | | | | | MISCELLANEOUS - 13 |
| WALLS | | | URINALS | | | | | FIREPLACE |
| BLANKET | | | KITCHEN SINKS | | | | | CANOPIES |
| | | | CIRCULAR SINK | | | | | FENCE |
| | | | SEMI-CIRC. SINK | | | | | FIRE ESCAPE |
| INTERIOR FIN. | | | SLOP SINK | | | | | LOADING DOCKS |
| LAYOUT | | | FOUNTAINS | | | | | |
| STRUCTURE | | | | | | | | |
| LOCATION | | | | | | | | |

| COMPUTATIONS | | | |
|----------------------------|---------------|-----------|--------|
| STORIES | AREA OR QUAN. | UNIT COST | TOTAL |
| 1 | 3729 | 6.85 | 25543 |
| ADDITIONS OR DEDUCTIONS | | | |
| NO. ITEM | AREA OR QUAN. | UNIT COST | TOTAL |
| 5A3 | 108 | 12.46 | + 2268 |
| 6B5 | 3 | 192 | + 570 |
| 8E | 3729 | 1.01 | - 3766 |
| 8P | 3 | 235 | + 705 |
| 9B | 3729 | 1.90 | + 7085 |
| TOTAL 32485 | | | |
| COST CONVERSION FACTOR 311 | | | |
| REPLACEMENT VALUE | | | |
| TOTAL | | | |
| COST CONVERSION FACTOR | | | |
| REPLACEMENT VALUE | | | |

1. 8-3-7
2. _____
3. _____

OWNER VERIFICATION

| CAP. IMPROV. | DATE | AMT |
|--------------|------|-----|
| Kit. | | |
| Plumb. | | |
| Heat | | |
| Attic | | |
| Bsmt. | | |
| Addit | | |

Neighborhood _____
NOTES

REPLACEMENT VALUE

Block: 4905 **Land Desc:** 49X158 **Owners Name:** LONDON, JAN **Land:** 192,900 **Exemption** **Net Taxable Value** **Deductions**
Lot: 18 **Bldg Desc:** 2S-AL-0-1UG **Street Address:** 23 ORCHARD ST **Bank:** 00000 **Impr:** 104,200 **Code:** **Cd No-Ow**
Qual: **Add Lots:** **City & State:** TEANECK NJ **Zip:** 07666 **Total:** 297,100 **Value:** 0 297,100
Card: M (#1 of 1) **Acreage:** 0.178 **Class:** 2 **Property Loc:** 23 ORCHARD ST **Zone:** BR **Map:** **TEANECK**

| SALES HISTORY | | | | | | | | | | ASSESSMENT HISTORY | | | | BUILDING PERMITS/REMARKS | | | |
|-------------------|----------|-----------|--------|-----|------|------------|--------|--------|-------------------|--------------------|------------------|--------------|------------|--|--|--|--|
| Grantor | Date | Book/Page | Price | Nu# | Year | Land | Impr | Total | | Date | Work Description | Amount | Compl. | | | | |
| | 08/08/85 | 6946 /61 | 113000 | | 2008 | 262100 | 117900 | 380000 | | | | | | | | | |
| LAND CALCULATIONS | | | | | | | | | | SITE INFORMATION | | | | RESIDENTIAL COST APPROACH | | | |
| Frnt | Rr | SB | T | FF | Avgd | Tabl | EqF | Rate | Site | Cond | Value | Road: | Utilities: | Basement | | | |
| | | | | | | | | | | | | PAVED | Sewer: YES | BASEMENT | | | |
| | | | | | | | | | | | | Curbs: YES | Water: YES | 572 x 9.600 + 2100 x1.00 x1.00= 7591 | | | |
| | | | | | | | | | | | | Sidewalk: NO | Gas: YES | Main Bldg | | | |
| | | | | | | | | | | | | Measured: AK | Topo: | FIRST STORY | | | |
| | | | | | | | | | | | | Inspected: Y | Neigh: 52 | UPPER STORY | | | |
| | | | | | | | | | | | | 03/25/14 | VCS: SF72 | 572 x 35.150 + 6600 x1.00 x1.00= 26706 | | | |
| | | | | | | | | | | | | | | Heat/AC | | | |
| | | | | | | | | | | | | | | HOT WATER OR ST | | | |
| | | | | | | | | | | | | | | 1404 x 3.740 + 1584 x1.00 x1.00= 6835 | | | |
| | | | | | | | | | | | | | | Plumbing | | | |
| | | | | | | | | | | | | | | 3 FIXTURE BATH | | | |
| | | | | | | | | | | | | | | 1- 2 x2595.000 + 0 x1.00 x1.00= -2595 | | | |
| | | | | | | | | | | | | | | 2 FIXTURE BATH | | | |
| | | | | | | | | | | | | | | 1- 1 x1895.000 + 0 x1.00 x1.00= 0 | | | |
| | | | | | | | | | | | | | | Fireplace | | | |
| | | | | | | | | | | | | | | Attic | | | |
| | | | | | | | | | | | | | | DORMER | | | |
| | | | | | | | | | | | | | | 8 x 136.000 + 0 x1.00 x1.00= 1088 | | | |
| | | | | | | | | | | | | | | FIN ATTIC | | | |
| | | | | | | | | | | | | | | 515 x 8.310 + 1380 x1.00 x1.00= 5660 | | | |
| | | | | | | | | | | | | | | UNFIN ATTIC | | | |
| | | | | | | | | | | | | | | 57 x 7.355 + 0 x1.00 x1.00= 419 | | | |
| | | | | | | | | | | | | | | Deck/Patio/Garage/Misc | | | |
| | | | | | | | | | | | | | | ENCLOSED PORCH | | | |
| | | | | | | | | | | | | | | 154 x 26.990 + 1092 x1.00 x1.00= 5248 | | | |
| | | | | | | | | | | | | | | 398300 | | | |
| | | | | | | | | | | | | | | 0 | | | |
| ROOM COUNT | | | | | | | | | | BASE COSTS | | | | | | | |
| | B | 1 | 2 | 3/A | Tot | Base Cost: | CCF: | CLA: | Cost New: | | | | | | | | |
| Living Rm | | 1 | | | 1 | 104178 | 135 | 110 | 154704 | | | | | | | | |
| Dining Rm | | 1 | | | 1 | 36.75 (Y) | | | Net Depr: 63.25 | | | | | | | | |
| Kitchen | | 1 | | | 1 | | | | Bldg Value: 97850 | | | | | | | | |
| Dinette | | | | | | | | | | | | | | | | | |
| 5 Fixt Bath | | | | | | | | | | | | | | | | | |
| 4 Fixt Bath | | | | | | | | | | | | | | | | | |
| 3 Fixt Bath | | | 1 | | 1 | | | | | | | | | | | | |
| 2 Fixt Bath | | 1 | | | 1 | | | | | | | | | | | | |
| Bed Room | | | 3 | | 3 | | | | | | | | | | | | |
| Fam Room | | | | | | | | | | | | | | | | | |
| Den/Other | | | | 2 | 2 | | | | | | | | | | | | |
| Old B: | | | | | | | | | | | | | | | | | |
| Old L: | | | | | | | | | | | | | | | | | |

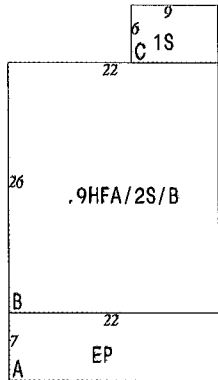

A:EP u0 r0;u7 r22
B:.9HFA/2S/B u7 r0;u26 r22
C:1S u33 r13;u6 r9
D:
E:
F:
G:
H:
I:
J:
K:
L:

154
572
54
0
0
0
0

M:
N:
O:
P:

Scale: 20

06/30/22

Land: 192,900 Impr: 104,200 Total: 297,100

Block: 4905 **Land Desc:** 98X155 **Owners Name:** 35 ORCHARD REALTY LLC **Land:** 175,200 **Exemption:** **Net Taxable Value:** **Deductions:**
Lot: 20 **Bldg Desc:** 1.5S-F-0-1UG **Street Address:** 35 ORCHARD ST **Bank:** 00000 **Impr:** 113,300 **Code:** **Cd No-Ow:**
Qual: **Add Lots:** **City & State:** TEANECK, NJ **Zip:** 07666 **Total:** 288,500 **Value:** 0 **288,500**
Card: M (#1 of 1) **Acreage:** 0.349 **Class:** 2 **Property Loc:** 35 ORCHARD ST **Zone:** R01 **Map:** **TEANECK**

| SALES HISTORY | | | | | ASSESSMENT HISTORY | | | | BUILDING PERMITS/REMARKS | | | |
|------------------------------|----------|-------------|--------|-----|--------------------|--------|--------|--------|--------------------------|------------------|--------|--------|
| Grantor | Date | Book/Page | Price | Nu# | Year | Land | Impr | Total | Date | Work Description | Amount | Compl. |
| KAHYAUGLU, GURKAN & KRISTINA | 04/23/21 | 4207 /1055 | 500000 | | 2021 | 175200 | 113300 | 288500 | | | | |
| | 05/08/08 | 9540 /1 | 327000 | | 2022 | 175200 | 113300 | 288500 | | | | |
| | 08/04/05 | 08874/00445 | 359000 | | | | | | | | | |
| | 01/09/87 | 07086/00240 | 149900 | | | | | | | | | |

| LAND CALCULATIONS | | | | | | | | | | SITE INFORMATION | | | | RESIDENTIAL COST APPROACH | | | |
|-------------------|----|----|---|----|------|------|-----|------|------|------------------|-------|--------------|------------|---------------------------|-----------------------------------|--------|--------|
| Frnt | Rr | SB | T | FF | Avgd | Tabl | EqF | Rate | Site | Cond | Value | Road: | Utilities: | Basement | Work Description | Amount | Compl. |
| | | | | | | | | | | | | PAVED | Sewer: YES | BASEMENT | 360 x 9.580 + 2112 x1.00 x1.00= | 5561 | |
| | | | | | | | | | | | | Curbs: YES | Water: YES | BASEMENT FIN | 324 x 13.500 + 1200 x1.00 x1.00= | 5574 | |
| | | | | | | | | | | | | Sidewalk: NO | Gas: YES | Main Bldg | | | |
| | | | | | | | | | | | | Measured: AK | Topo: | FIRST STORY | 1068 x 49.180 +22440 x1.00 x1.00= | 74964 | |
| | | | | | | | | | | | | Inspected: Y | Neigh: 12 | | | | |
| | | | | | | | | | | | | 03/25/14 | VCS: SF12 | | | | |

| BUILDING INFORMATION | | | | | | | | | | Plumbing | | | | | |
|----------------------|------------------|-----------------|----------------------------------|---------------------------------|--------|------------|------------------|------------------|----------|----------------------|---------------|------------------------|--------------------------------|--------|--------|
| Type and Use: | Class/Quality: | Heat/AC | Work Description | Amount | Compl. | Style: | Year Built/EffA: | Exterior Finish: | Windows: | Roof Type: | Livable Area: | Attic | Work Description | Amount | Compl. |
| ONE FAMILY | 16 | FORCED HOT AIR | 1672 x 2.400 + 960 x1.00 x1.00= | 4973 | | RANCH | 1910 / 99 (Y) | ALUM/VINYL | | GABLE | 1348 SF | DORMER | 10 x 129.000 + 0 x1.00 x1.00= | 1290 | |
| Story Height: | Condition: | AC ADDED TO HOT | 1672 x 0.890 + 2160 x1.00 x1.00= | 3648 | | Updates | | | | ASPHALT SHINGLE | Updates | FIN ATTIC | 702 x 9.110 + 840 x1.00 x1.00= | 7235 | |
| Style: | Year Built/EffA: | Plumbing | 3 FIXTURE BATH | 1- 2 x2595.000 + 0 x1.00 x1.00= | -2595 | RANCH | 1910 / 99 (Y) | | | CONCRETE BLOCK | SHEETROCK | UNFIN ATTIC | 78 x 7.355 + 0 x1.00 x1.00= | 574 | |
| Exterior Finish: | Windows: | 2 FIXTURE BATH | 0- 1 x1895.000 + 0 x1.00 x1.00= | -1895 | | ALUM/VINYL | | | | Baths: M:1 A: O: | | Deck/Patio/Garage/Misc | | | |
| Roof Type: | Livable Area: | Fireplace | | | | | | | | Kitchens: M:31 A: O: | | DECK | 270 x 5.203 + 203 x1.00 x1.00= | 1608 | |
| Roof Material: | Interior Cond: | | | | | | | | | | | 379200 | | 0 | |
| Foundation: | Interior Wall: | | | | | | | | | | | | | | |

| ROOM COUNT | | | | | | Base Cost: | | | Detached Items: | | | |
|-------------|---|---|---|-----|-----|----------------------|-------------|----------|--------------------|----------------|----------------------|------|
| | B | 1 | 2 | 3/A | Tot | 100937 | CCF: 135 | CLA: 100 | Cost New: | 198 x 31.390 + | 0 x1.00 x0.37 x1.35= | 3104 |
| Living Rm | | 1 | | | 1 | 136265 | | | 136265 | | | |
| Dining Rm | | 1 | | | 1 | Phys Depr: 19.15 (Y) | Func Depr: | | Net Depr: 80.85 | | | |
| Kitchen | | 1 | | | 1 | Loc Depr: | Mkt+: Mkt-: | | Bldg Value: 110167 | | | |
| Dinette | | | | | | | | | | | | |
| 5 Fixt Bath | | | | | | | | | | | | |
| 4 Fixt Bath | | | | | | | | | | | | |
| 3 Fixt Bath | | 1 | | | 1 | | | | | | | |
| 2 Fixt Bath | | | | | | | | | | | | |
| Bed Room | | | 1 | | 1 | | | | | | | |
| Fam Room | 1 | | | | 1 | | | | | | | |
| Den/Other | | 1 | 1 | | 2 | | | | | | | |
| Old B: | | | | | 6 | | | | | | | |
| Old L: | | | | | | | | | | | | |

A: 1S u0 r0;u8 r26 208
 B: .9HFA/1S/.9HFBu8 r14;u30 r12 360
 C: 1S u38 r12;u5 r10 50
 D: 1SOH u23 r26;u15 r2 30
 E: .9HFA/1S u8 r0;u30 r14 420
 F: WD u23 r28;u15 l2 l4 u5 r18 d20 l12 270
 G: 0
 H: 0
 I: 0
 J: M:
 K: N:
 L: O:
 P:

Scale: 20

Land: 175,200 **Impr:** 113,300 **Total:** 288,500

Block: 4905 Land Desc: 55X193 Owners Name: MCKENZIE, DIMIAN & SHAREE Land: 158,500 Exemption Net Taxable Value Deductions
 Lot: 22.01 Bldg Desc: 2S-L- Street Address: 1335 GRAHAM PLACE Bank: 00000 Impr: 273,400 Code: Cd No-Ow
 Qual: Addl Lots: City & State: TEANECK, NJ Zip: 07666 Total: 431,900 Value: 0 431,900
 Card: M (#1 of 1) Acreage: 0.177 Class: 2 Property Loc: 1335 GRAHAM PL Zone: R01 Map: TEANECK

| SALES HISTORY | | | | | ASSESSMENT HISTORY | | | | BUILDING PERMITS/REMARKS | | | |
|-----------------------------|----------|-----------|--------|-----|--------------------|--------|--------|--------|--------------------------|---------------------------|--------|----------|
| Grantor | Date | Book/Page | Price | Nu# | Year | Land | Impr | Total | Date | Work Description | Amount | Compl. |
| 1335 GRAHAM PLACE LLC | 11/12/20 | 3941 /70 | 550000 | 7 | 2020 | 158500 | 273400 | 431900 | 08/16/19 | ADDITION/ALTER 1 & 2ND FL | 90000 | 09/01/20 |
| MTGLQ INVESTORS LP | 04/04/19 | 3241 /212 | 165000 | 31 | | | | | | | | |
| SAUDINO, MICHAEL CB SHERIFF | 03/13/18 | 2977 /164 | 100 | 12 | | | | | | | | |
| | 09/14/05 | 8910 /289 | 330000 | | | | | | | | | |

| LAND CALCULATIONS | | | | | | | | | | SITE INFORMATION | | | | RESIDENTIAL COST APPROACH | | | |
|-------------------|----|----|---|----|------|------|-----|------|------|------------------|-------|--------------|------------|---------------------------|---------------------------------------|-------|--|
| Fr | Rr | SB | T | FF | Avgd | Tabl | EqF | Rate | Site | Cond | Value | Road: | Utilities: | Basement | | | |
| | | | | | | | | | | | | PAVED | Sewer: YES | BASEMENT | 1010 x 9.460 + 2220 x 1.15 x 1.00 = | 13541 | |
| | | | | | | | | | | | | Curbs: YES | Water: YES | BASEMENT FIN | 606 x 13.330 + 1302 x 1.15 x 1.00 = | 10787 | |
| | | | | | | | | | | | | Sidewalk: NO | Gas: YES | Main Bldg | | | |
| | | | | | | | | | | | | Measured: AK | Topo: | FIRST STORY | 1050 x 59.080 + 26950 x 1.00 x 1.00 = | 88984 | |
| | | | | | | | | | | | | Inspected: N | Neigh: 12 | UPPER STORY | 1050 x 42.110 + 7920 x 1.00 x 1.00 = | 52136 | |
| | | | | | | | | | | | | 3/24/14 | VCS: SF12 | | | | |

Net Adj: 100.00 SF: 7,699 Auto: Y Land Value: 158,500

2014-HOUSE IS VACANT
NEW HOME/XST FD

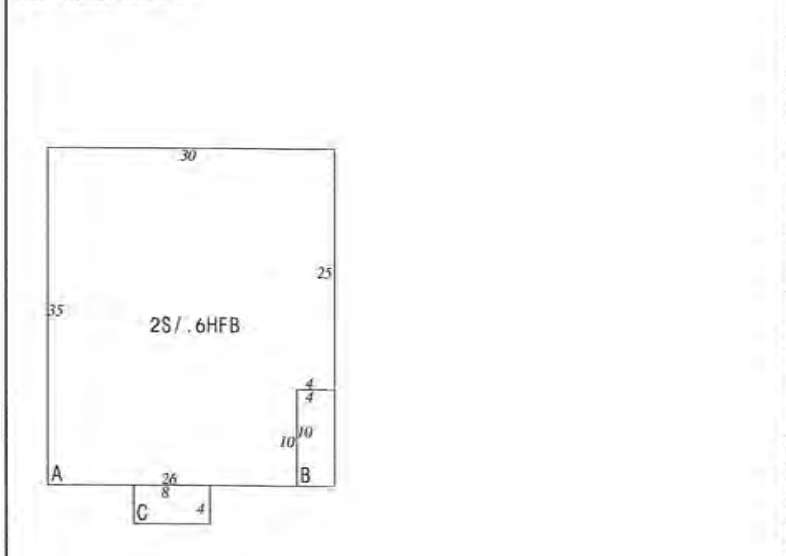

A: 2S/.6HFB u0 r0;u35r30d25l4d10l26
 B: 2S/CR u0 r26;u10 r4
 C: OP u0 r9;r8d4
 D:
 E:
 F:
 G:
 H:
 I:
 J:
 K:
 L:
 M:
 N:
 O:
 P:

Scale: 20

| BUILDING INFORMATION | | | |
|----------------------|-----------------|------------------|------------|
| Type and Use: | ONE FAMILY | Class/Quality: | 17 |
| Story Height: | | Condition: | TYPICAL |
| Style: | SMALL COLONIAL | Year Built/EffA: | 2020 / () |
| Exterior Finish: | VINYL SIDING | Windows: | |
| Roof Type: | GABLE | Livable Area: | 2100 SF |
| Roof Material: | ASPHALT SHINGLE | Interior Cond: | TYPICAL |
| Foundation: | CONCRETE BLOCK | Interior Wall: | SHEETROCK |
| Baths: M: | A: 4 O: | | |
| Kitchens: M: | A: 1 O: | | |

| ROOM COUNT | | | | | |
|-------------|---|---|---|-----|-----|
| | B | 1 | 2 | 3/A | Tot |
| Living Rm | | 1 | | | 1 |
| Dining Rm | | 1 | | | 1 |
| Kitchen | | 1 | | | 1 |
| Dinette | | | | | |
| 5 Fixt Bath | | | | | |
| 4 Fixt Bath | | | 1 | | 1 |
| 3 Fixt Bath | 1 | | 1 | | 2 |
| 2 Fixt Bath | | 1 | | | 1 |
| Bed Room | | | 4 | | 4 |
| Fam Room | | 1 | | | 1 |
| Den/Other | 1 | | | | 1 |

Old B: 4905 8
 Old L: 4 06/22/22

Base Cost: 184122 CCF: 135 CLA: 110 Cost New: 273421
 Phys Depr: 0.00 (Y) Func Depr: Net Depr: 100.00
 Loc Depr: Mkt+: Mkt-: Bldg Value: 273421

Detached Items:
 Land: 158,500 Impr: 273,400 Total: 431,900

Appendix C:

Municipal Records: Tax Collector

BLQ: 4905. 1.
Owner Name: DRASKIN, PETER

Tax Year: 2022 to 2022
Property Location: 61 GRAHAM PL

| Tax Year: 2022 | Qtr 1 | Qtr 2 | Qtr 3 | Qtr 4 | Total |
|------------------|----------|----------|----------|-------|----------|
| Original Billed: | 3,134.00 | 3,134.00 | 3,143.43 | 0.00 | 9,411.43 |
| Payments: | 3,134.00 | 3,134.00 | 0.00 | 0.00 | 6,268.00 |
| Balance: | 0.00 | 0.00 | 3,143.43 | 0.00 | 3,143.43 |

| Date | Qtr | Type | Code | Check No | Mthd | Reference | Batch Id | Principal | Interest | 2022 Prin Balance |
|----------|-----|-----------|------|----------|------|------------|----------|-----------|----------|-------------------|
| | | | | | | | | 9,411.43 | | 9,411.43 |
| 02/07/22 | 1 | Payment | 005 | WIRE | CK | 24329 3925 | F37NATM | 3,134.00 | 0.00 | 6,277.43 |
| | | CORELOGIC | | | | | | | | |
| 05/04/22 | 2 | Payment | 005 | WIRE | CK | 24769 3977 | 024NATM | 3,134.00 | 0.00 | 3,143.43 |
| | | CORELOGIC | | | | | | | | |

Total Principal Balance for Tax Years in Range: 3,143.43

BLQ: 4905, 2.
Owner Name: 54 WEST ENGLEWOOD AVE LLC

Tax Year: 2022 to 2022
Property Location: 1347 MERSEREAU TERR

| Tax Year: 2022 | Qtr 1 | Qtr 2 | Qtr 3 | Qtr 4 | Total |
|------------------|----------|----------|----------|-------|----------|
| Original Billed: | 1,950.00 | 1,950.00 | 1,955.05 | 0.00 | 5,855.05 |
| Payments: | 1,950.00 | 1,950.00 | 0.00 | 0.00 | 3,900.00 |
| Balance: | 0.00 | 0.00 | 1,955.05 | 0.00 | 1,955.05 |

| Date | Qtr | Type | Code | Check No | Mthd | Reference | Batch Id | Principal | Interest | 2022 Prin Balance |
|----------|-----|---------|--------------------|------------|------|-----------|-------------|-----------|----------|-------------------|
| | | | Description | | | | | | | |
| | | | Original Billed | | | | | 5,855.05 | | 5,855.05 |
| 02/10/22 | 1 | Payment | 005 | 1057 | CK | 24345 | 37 F53NAT | 1,950.00 | 0.00 | 3,905.05 |
| | | | 54 W ENGLEWOOD AVE | | | | | | | |
| 05/16/22 | 2 | Payment | 005 | 3829367083 | CK | 24873 | 11 M077WIPP | 1,950.00 | 8.38 | 1,955.05 |
| | | | WIPP PAYMENT | | | | | | | |

Total Principal Balance for Tax Years in Range: 1,955.05

BLQ: 4905. 3.
Owner Name: SADIQULLA, MOHAMMED

Tax Year: 2022 to 2022
Property Location: 54 W ENGLEWOOD AVE

| Tax Year: 2022 | Qtr 1 | Qtr 2 | Qtr 3 | Qtr 4 | Total |
|------------------|----------|----------|----------|-------|----------|
| Original Billed: | 2,878.00 | 2,878.00 | 2,887.45 | 0.00 | 8,643.45 |
| Payments: | 2,878.00 | 2,878.00 | 0.00 | 0.00 | 5,756.00 |
| Balance: | 0.00 | 0.00 | 2,887.45 | 0.00 | 2,887.45 |

| Date | Qtr | Type | Code | Check No | Mthd | Reference | Batch Id | Principal | Interest | 2022 Prin Balance |
|----------|-----|-------------|------|------------|------|-----------|-------------|-----------|----------|-------------------|
| | | | | | | | | 8,643.45 | | 8,643.45 |
| 02/10/22 | 1 | Payment | 005 | 1056 | CK | 24345 | 38 F53NAT | 2,878.00 | 0.00 | 5,765.45 |
| | | Description | | | | | | | | |
| | | | | | | | | | | |
| | | | | | | | | | | |
| 05/16/22 | 2 | Payment | 005 | 3829367209 | CK | 24873 | 12 M077WIPP | 2,878.00 | 15.34 | 2,887.45 |
| | | Description | | | | | | | | |
| | | | | | | | | | | |
| | | | | | | | | | | |
| | | | | | | | | | | |

Total Principal Balance for Tax Years in Range: 2,887.45

BLQ: 4905, 4.01
Owner Name: ORDUKHANYAN, ASHOT

Tax Year: 2022 to 2022
Property Location: 44 W ENGLEWOOD AVE

| Tax Year: 2022 | Qtr 1 | Qtr 2 | Qtr 3 | Qtr 4 | Total |
|------------------|----------|----------|----------|-------|----------|
| Original Billed: | 2,664.00 | 2,664.00 | 2,672.63 | 0.00 | 8,000.63 |
| Payments: | 2,664.00 | 2,664.00 | 0.00 | 0.00 | 5,328.00 |
| Balance: | 0.00 | 0.00 | 2,672.63 | 0.00 | 2,672.63 |

| Date | Qtr | Type | Code | Check No | Mthd | Reference | Batch Id | Principal | Interest | 2022 Prin Balance |
|----------|-----|------------------------------|------|------------|------|-----------|-------------|-----------|----------|-------------------|
| | | | | | | | | 8,000.63 | | 8,000.63 |
| 11/01/21 | 1 | Payment | 005 | | CS | 23760 | 70 N05NAT | 26.00 | 0.00 | 7,974.63 |
| | | Description: Original Billed | | | | | | | | |
| | | Description: ORDUKHANYAN | | | | | | | | |
| 02/04/22 | 1 | Payment | 005 | 3823046298 | CK | 24316 | 56 F33WIPP | 2,638.00 | 0.00 | 5,336.63 |
| | | Description: WIPP | | | | | | | | |
| 05/03/22 | 2 | Payment | 005 | 3828595983 | CK | 24757 | 59 M019WIPP | 2,664.00 | 0.00 | 2,672.63 |

Total Principal Balance for Tax Years in Range: 2,672.63

BLQ: 4905, 6.
Owner Name: KEITT, STEPHEN

Tax Year: 2022 to 2022
Property Location: 32 W ENGLEWOOD AVE

| Tax Year: 2022 | Qtr 1 | Qtr 2 | Qtr 3 | Qtr 4 | Total |
|------------------|----------|----------|----------|-------|----------|
| Original Billed: | 2,825.00 | 2,825.00 | 2,834.47 | 0.00 | 8,484.47 |
| Payments: | 2,825.00 | 2,825.00 | 0.00 | 0.00 | 5,650.00 |
| Balance: | 0.00 | 0.00 | 2,834.47 | 0.00 | 2,834.47 |

| Date | Qtr | Type | Code | Check No | Mthd | Reference | Batch Id | Principal | Interest | 2022 Prin Balance |
|----------|-----|-----------|------|----------|------|------------|----------|-----------|----------|-------------------|
| | | | | | | | | 8,484.47 | | 8,484.47 |
| 02/07/22 | 1 | Payment | 005 | WIRE | CK | 24329 3926 | F37NATM | 2,825.00 | 0.00 | 5,659.47 |
| | | CORELOGIC | | | | | | | | |
| 05/04/22 | 2 | Payment | 005 | WIRE | CK | 24769 3978 | 024NATM | 2,825.00 | 0.00 | 2,834.47 |
| | | CORELOGIC | | | | | | | | |

Total Principal Balance for Tax Years in Range: 2,834.47

BLQ: 4905. 7.
Owner Name: 26 WEST ENGLEWOOD LLC

Tax Year: 2022 to 2022
Property Location: 26 W ENGLEWOOD AVE

| Tax Year: 2022 | Qtr 1 | Qtr 2 | Qtr 3 | Qtr 4 | Total |
|------------------|----------|----------|----------|-------|----------|
| Original Billed: | 2,084.00 | 2,084.00 | 2,090.08 | 0.00 | 6,258.08 |
| Payments: | 2,084.00 | 2,080.88 | 0.00 | 0.00 | 4,164.88 |
| Balance: | 0.00 | 3.12 | 2,090.08 | 0.00 | 2,093.20 |

| Date | Qtr | Type | Code | Check No | Mthd | Reference | Batch Id | Principal | Interest | 2022 Prin Balance |
|----------|-----|----------------------|------|-----------|------|-----------|------------|-----------|----------|-------------------|
| | | | | | | | | 6,258.08 | | 6,258.08 |
| 02/23/22 | 1 | Payment | 006 | 53070 | CK | 24417 | 5 F97SUBS | 2,084.00 | 22.92 | 4,174.08 |
| | | Original Billed | | | | | | | | |
| | | ACTLIEN HOLDING INC. | | | | | | | | |
| 05/23/22 | 2 | Payment | 006 | 54508 L/H | CK | 24896 | 4 M097SUBS | 2,080.88 | 22.92 | 2,093.20 |
| | | ACTLIEN HOLDING, INC | | | | | | | | |

Total Principal Balance for Tax Years in Range: 2,093.20

Miscellaneous Payments for Date Range 01/01/22 to 12/31/22:

| Date | Type | Code | Check No | Mthd | Reference | Batch Id | Principal | Interest | Total |
|----------|------------------------------|------|----------|------|-----------|--------------|-----------|----------|-----------|
| 01/13/22 | Payment | 907 | | CK | 24189 | 194 TAX SALE | 30,900.00 | 0.00 | 30,900.00 |
| | Description TAX SALE | | | | | | | | |
| 01/13/22 | Payment | 908 | | CK | 24189 | 193 TAX SALE | 0.00 | 93.02 | 93.02 |
| | Description TAX SALE COST | | | | | | | | |

30,993.02

*Paid 7/18/22
per tax collector
on 7/19/22*

Lien

BLQ: 4905. 8.
Owner Name: 22 WEST ENGLEWOOD LLC

Tax Year: 2022 to 2022
Property Location: 22 W ENGLEWOOD AVE

| Tax Year: 2022 | Qtr 1 | Qtr 2 | Qtr 3 | Qtr 4 | Total |
|------------------|----------|----------|----------|-------|----------|
| Original Billed: | 2,734.00 | 2,734.00 | 2,742.85 | 0.00 | 8,210.85 |
| Payments: | 2,734.00 | 2,734.00 | 0.00 | 0.00 | 5,468.00 |
| Balance: | 0.00 | 0.00 | 2,742.85 | 0.00 | 2,742.85 |

| Date | Qtr | Type | Code | Check No | Mthd | Reference | Batch Id | Principal | Interest | 2022 Prin Balance |
|----------|-----|---|------|----------|------|-----------|-----------|-----------|----------|-------------------|
| | | | | | | | | 8,210.85 | | 8,210.85 |
| 02/22/22 | 1 | Payment | 006 | 5030 L/H | CK | 24404 | 9 F92SUBS | 2,734.00 | 28.71 | 5,476.85 |
| | | Description: Original Billed FIRST NATIONAL HOLD | | | | | | | | |
| 06/16/22 | 2 | Payment | 006 | 5213 | CK | 24986 | 4 040SUBS | 2,734.00 | 61.52 | 2,742.85 |
| | | Description: FIRST NATL HOLDINGS | | | | | | | | |

Total Principal Balance for Tax Years in Range: 2,742.85

Miscellaneous Payments for Date Range 01/01/22 to 12/31/22:

| Date | Type | Code | Check No | Mthd | Reference | Batch Id | Principal | Interest | Total | |
|----------|----------------------------|------|----------|------|-----------|--------------|-----------|----------|------------------|--|
| 01/13/22 | Payment | 907 | | CK | 24189 | 199 TAX SALE | 51,000.00 | 0.00 | 51,000.00 | |
| | Description: TAX SALE | | | | | | | | | |
| 01/13/22 | Payment | 908 | | CK | 24189 | 198 TAX SALE | 0.00 | 150.00 | 150.00 | |
| | Description: TAX SALE COST | | | | | | | | | |
| | | | | | | | | | <u>51,150.00</u> | |

Lien current
per tax collector
on 7/19/22

Lien

BLQ: 4905, 9.
Owner Name: 20 WEST ENGLEWOOD LLC

Tax Year: 2022 to 2022
Property Location: 20 W ENGLEWOOD AVE

| Tax Year: 2022 | Qtr 1 | Qtr 2 | Qtr 3 | Qtr 4 | Total |
|------------------|----------|----------|----------|-------|----------|
| Original Billed: | 2,579.00 | 2,579.00 | 2,586.43 | 0.00 | 7,744.43 |
| Payments: | 2,579.00 | 2,579.00 | 0.00 | 0.00 | 5,158.00 |
| Balance: | 0.00 | 0.00 | 2,586.43 | 0.00 | 2,586.43 |

| Date | Qtr | Type | Code | Check No | Mthd | Reference | Batch Id | Principal | Interest | 2022 Prin Balance | |
|----------|-----|----------------------------------|------|----------|------|-----------|----------|-----------|----------|-------------------|----------|
| | | | | | | | | 7,744.43 | | 7,744.43 | |
| 02/22/22 | 1 | Payment | 006 | 5024 | L/H | CK | 24404 10 | F92SUBS | 2,579.00 | 27.08 | 5,165.43 |
| | | Description: Original Billed | | | | | | | | | |
| | | Description: FIRST NATIONAL HOLD | | | | | | | | | |
| 06/16/22 | 2 | Payment | 006 | 5212 | | CK | 24986 5 | 040SUBS | 2,579.00 | 58.03 | 2,586.43 |
| | | Description: FIRST NATL HOLDINGS | | | | | | | | | |

Total Principal Balance for Tax Years in Range: 2,586.43

Miscellaneous Payments for Date Range 01/01/22 to 12/31/22:

| Date | Type | Code | Check No | Mthd | Reference | Batch Id | Principal | Interest | Total |
|----------|----------------------------|------|----------|------|-----------|--------------|-----------|------------------|-----------|
| 01/13/22 | Payment | 907 | | CK | 24189 | 204 TAX SALE | 48,100.00 | 0.00 | 48,100.00 |
| | Description: TAX SALE | | | | | | | | |
| 01/13/22 | Payment | 908 | | CK | 24189 | 203 TAX SALE | 0.00 | 150.00 | 150.00 |
| | Description: TAX SALE COST | | | | | | | | |
| | | | | | | | | <u>48,250.00</u> | |

*Paid 7/18/22, no lien
per tax collector
on 7/19/22*

BLQ: 4905. 11. -c0001- - Tax Year: 2022 to 2022
 Owner Name: JUNG, JOOHO & LEE, CHONG IM Property Location: 1360 TEANECK ROAD

| Tax Year: 2022 | Qtr 1 | Qtr 2 | Qtr 3 | Qtr 4 | Total |
|------------------|----------|----------|----------|-------|----------|
| Original Billed: | 2,261.00 | 2,261.00 | 2,268.53 | 0.00 | 6,790.53 |
| Payments: | 2,261.00 | 2,261.00 | 0.00 | 0.00 | 4,522.00 |
| Balance: | 0.00 | 0.00 | 2,268.53 | 0.00 | 2,268.53 |

| Date | Qtr | Type | Code | Check No | Mthd | Reference | Batch Id | Principal | Interest | 2022 Prin Balance |
|----------|-----|--------------|------|------------|------|-----------|------------|-----------|----------|-------------------|
| | | | | | | | | 6,790.53 | | 6,790.53 |
| 01/26/22 | 1 | Payment | 005 | 3822379300 | CK | 24253 | 24 086WIPP | 2,261.00 | 0.00 | 4,529.53 |
| 04/28/22 | 2 | Payment | 005 | 3828245512 | CR | 24734 | 51 092WIPP | 2,261.00 | 0.00 | 2,268.53 |
| | | WIPP PAYMENT | | | | | | | | |

Total Principal Balance for Tax Years in Range: 2,268.53

BLQ: 4905, 11, -C0002--
Owner Name: JOOHO JUNG & CHONG IM LEE

Tax Year: 2022 to 2022
Property Location: 1362 TEANECK RD

| Tax Year: 2022 | Qtr 1 | Qtr 2 | Qtr 3 | Qtr 4 | Total |
|------------------|--------|--------|--------|-------|----------|
| Original Billed: | 834.00 | 834.00 | 837.27 | 0.00 | 2,505.27 |
| Payments: | 834.00 | 834.00 | 0.00 | 0.00 | 1,668.00 |
| Balance: | 0.00 | 0.00 | 837.27 | 0.00 | 837.27 |

| Date | Qtr | Type | Code | Check No | Mthd | Reference | Batch Id | Principal | Interest | 2022 Prin Balance |
|----------|-----|--------------|------|------------|------|-----------|------------|-----------|----------|-------------------|
| | | | | | | | | 2,505.27 | | 2,505.27 |
| 01/26/22 | 1 | Payment | 005 | 3822379454 | CK | 24253 | 25 086WIPP | 834.00 | 0.00 | 1,671.27 |
| 04/28/22 | 2 | Payment | 005 | 3828245748 | CR | 24734 | 52 092WIPP | 834.00 | 0.00 | 837.27 |
| | | WIPP PAYMENT | | | | | | | | |

Total Principal Balance for Tax Years in Range: 837.27

BLQ: 4905. 11. -C0003-
Owner Name: IM, JENNY GIWON&DANIEL

Tax Year: 2022 to 2022
Property Location: 1364 TEANECK RD

| Tax Year: 2022 | Qtr 1 | Qtr 2 | Qtr 3 | Qtr 4 | Total |
|------------------|----------|----------|----------|-------|----------|
| Original Billed: | 1,543.00 | 1,543.00 | 1,548.43 | 0.00 | 4,634.43 |
| Payments: | 1,543.00 | 1,543.00 | 0.00 | 0.00 | 3,086.00 |
| Balance: | 0.00 | 0.00 | 1,548.43 | 0.00 | 1,548.43 |

| Date | Qtr | Type | Code | Check No | Mthd | Reference | Batch Id | Principal | Interest | 2022 Prin Balance |
|----------|-----|---------|-----------------|------------|------|-----------|-------------|-----------|----------|-------------------|
| | | | Original Billed | | | | | 4,634.43 | | 4,634.43 |
| 11/03/21 | 1 | Payment | 005 | | CS | 23778 | 6 N21NAT | 51.05 | 0.00 | 4,583.38 |
| 02/07/22 | 1 | Payment | 005 | | CS | 24328 | 13 F36NAT | 1,491.95 | 0.00 | 3,091.43 |
| 05/02/22 | 2 | Payment | 005 | 3828556781 | CK | 24747 | 96 M010WIPP | 1,543.00 | 0.00 | 1,548.43 |

Total Principal Balance for Tax Years in Range: 1,548.43

BLQ: 4905, 12, Tax Year: 2022 to 2022
 Owner Name: WEL MANAGED RLTY & LEVIE, WARREN Property Location: 1354-1358 TEANECK RD

| Tax Year: 2022 | Qtr 1 | Qtr 2 | Qtr 3 | Qtr 4 | Total |
|------------------|-----------------|-----------------|-----------------|-------------|------------------|
| Original Billed: | 5,438.00 | 5,438.00 | 5,453.74 | 0.00 | 16,329.74 |
| Payments: | 16.17 | 0.00 | 0.00 | 0.00 | 16.17 |
| Balance: | 5,421.83 | 5,438.00 | 5,453.74 | 0.00 | 16,313.57 |

| Date | Qtr | Type | Code | Check No | Mthd | Reference | Batch Id | Principal | Interest | 2022 Prin Balance |
|----------|-----|--------------------|-----------------|----------|------|-----------|----------|-----------|----------|-------------------|
| | | | Description | | | | | | | |
| | | | Original Billed | | | | | 16,329.74 | | 16,329.74 |
| 12/10/21 | 1 | Payment | 005 | 2534 | CK | 24026 | 6 29JALM | 16.17 | 0.00 | 16,313.57 |
| | | WEL MANAGED REALTY | | | | | | | | |

Total Principal Balance for Tax Years in Range: 16,313.57

BLQ: 4905. 13.
Owner Name: JALASAI LLC

Tax Year: 2022 to 2022
Property Location: 1348-1352 TEANECK RD

| Tax Year: 2022 | Qtr 1 | Qtr 2 | Qtr 3 | Qtr 4 | Total |
|------------------|----------|----------|----------|-------|-----------|
| Original Billed: | 4,990.00 | 4,990.00 | 5,004.97 | 0.00 | 14,984.97 |
| Payments: | 4,990.00 | 4,990.00 | 0.00 | 0.00 | 9,980.00 |
| Balance: | 0.00 | 0.00 | 5,004.97 | 0.00 | 5,004.97 |

| Date | Qtr | Type | Code | Check No | Mthd | Reference | Batch Id | Principal | Interest | 2022 Prin Balance |
|----------|-----|---------|---------------------|----------|------|-----------|------------|-----------|----------|-------------------|
| | | | Description | | | | | | | |
| | | | Original Billed | | | | | 14,984.97 | | 14,984.97 |
| 01/31/22 | 1 | Payment | 005 | 9411 | CK | 24272 | 8 103JALM | 4,990.00 | 0.00 | 9,994.97 |
| | | | FIRST COMMERCE BANK | | | | | | | |
| 04/18/22 | 2 | Payment | 005 | 9563 | CK | 24672 | 19 044JALM | 4,990.00 | 0.00 | 5,004.97 |
| | | | 1ST COMM/JALASAI | | | | | | | |

Total Principal Balance for Tax Years in Range: 5,004.97

BLQ: 4905. 14.
Owner Name: TOWNSHIP OF TEANECK

Tax Year: 2022 to 2022
Property Location: 1344 TEANECK RD

| Tax Year: 2022 | Qtr 1 | Qtr 2 | Qtr 3 | Qtr 4 | Total | | | | |
|----------------|-------|-------|-------|-------|-------|--|--|--|--|
| Payments: | 0.00 | 0.00 | 0.00 | 0.00 | 0.00 | | | | |
| Balance: | 0.00 | 0.00 | 0.00 | 0.00 | 0.00 | | | | |

| Date | Qtr | Type | Code | Check No | Mthd | Reference | Batch Id | Principal | Interest | 2022 Prin Balance |
|------|-----|-----------------|------|----------|------|-----------|----------|-----------|----------|-------------------|
| | | Description | | | | | | | | |
| | | Original Billed | | | | | | 0.00 | | 0.00 |

Total Principal Balance for Tax Years in Range: 0.00

BLQ: 4905, 15
Owner Name: PERSAUD, SOOKDEO

Tax Year: 2022 to 2022
Property Location: 1338-1340 TEANECK RD

| Tax Year: 2022 | Qtr 1 | Qtr 2 | Qtr 3 | Qtr 4 | Total |
|------------------|----------|----------|----------|-------|-----------|
| Original Billed: | 4,078.00 | 4,078.00 | 4,090.81 | 0.00 | 12,246.81 |
| Payments: | 4,078.00 | 4,078.00 | 0.00 | 0.00 | 8,156.00 |
| Balance: | 0.00 | 0.00 | 4,090.81 | 0.00 | 4,090.81 |

| Date | Qtr | Type | Code | Check No | Mthd | Reference | Batch Id | Principal | Interest | 2022 Prin Balance |
|----------|-----|---------|------|----------|------|-----------|------------|-----------|----------|-------------------|
| | | | | | | | | 12,246.81 | | 12,246.81 |
| 02/16/22 | 1 | Payment | 005 | 1055 | CK | 24382 | 2 F73NAT | 4,078.00 | 24.34 | 8,168.81 |
| | | PERSAUD | | | | | | | | |
| 05/06/22 | 2 | Payment | 005 | 1065 | CK | 24792 | 34 N035NAT | 4,078.00 | 0.00 | 4,090.81 |
| | | PERSAUD | | | | | | | | |

Total Principal Balance for Tax Years in Range: 4,090.81

BLQ: 4905. 17.
Owner Name: MARTINEZ, DIOSMARY

Tax Year: 2022 to 2022
Property Location: 1334 TEANECK RD

| Tax Year: 2022 | Qtr 1 | Qtr 2 | Qtr 3 | Qtr 4 | Total |
|------------------|----------|----------|----------|-------|----------|
| Original Billed: | 2,141.00 | 2,141.00 | 2,147.22 | 0.00 | 6,429.22 |
| Payments: | 2,141.00 | 2,141.00 | 0.00 | 0.00 | 4,282.00 |
| Balance: | 0.00 | 0.00 | 2,147.22 | 0.00 | 2,147.22 |

| Date | Qtr | Type | Code | Check No | Mthd | Reference | Batch Id | Principal | Interest | 2022 Prin Balance |
|----------|-----|---------------------|------|----------|------|-----------|------------|-----------|----------|-------------------|
| | | | | | | | | 6,429.22 | | 6,429.22 |
| 02/10/22 | 1 | Payment | 005 | 6616 | CK | 24348 | 7 F56JESS | 2,141.00 | 0.00 | 4,288.22 |
| | | Original Billed | | | | | | | | |
| | | ELSA'S BEAUTY SALON | | | | | | | | |
| 05/10/22 | 2 | Payment | 005 | 6645 | CK | 24806 | 21 M048NAT | 2,141.00 | 0.00 | 2,147.22 |
| | | ELSA'S BEAUTY SALON | | | | | | | | |

Total Principal Balance for Tax Years in Range: 2,147.22

BLQ: 4905, 18.
Owner Name: LONDON, JAN

Tax Year: 2022 to 2022
Property Location: 23 ORCHARD ST

| Tax Year: 2022 | Qtr 1 | Qtr 2 | Qtr 3 | Qtr 4 | Total |
|------------------|----------|----------|----------|-------|----------|
| Original Billed: | 2,418.00 | 2,418.00 | 2,426.22 | 0.00 | 7,262.22 |
| Payments: | 2,418.00 | 2,418.00 | 0.00 | 0.00 | 4,836.00 |
| Balance: | 0.00 | 0.00 | 2,426.22 | 0.00 | 2,426.22 |

| Date | Qtr | Type | Code | Check No | Mthd | Reference | Batch Id | Principal | Interest | 2022 Prin Balance |
|----------|-----|------------------|-----------------|----------|------|-----------|------------|-----------|----------|-------------------|
| | | | Original Billed | | | | | 7,262.22 | | 7,262.22 |
| 01/31/22 | 1 | Payment | 005 | 1485 | CK | 24267 | 20 099NAT | 2,418.00 | 0.00 | 4,844.22 |
| | | ALEMBIC RLTY LLC | | | | | | | | |
| 04/28/22 | 2 | Payment | 005 | 5472 | CK | 24730 | 19 088JESS | 2,418.00 | 0.00 | 2,426.22 |
| | | LONDON | | | | | | | | |

Total Principal Balance for Tax Years in Range: 2,426.22

BLQ: 4905, 19.
Owner Name: SOLARTE, JIMMY&FRIAS, JOANNA VARGAS

Tax Year: 2022 to 2022
Property Location: 27 ORCHARD ST

| Tax Year: 2022 | Qtr 1 | Qtr 2 | Qtr 3 | Qtr 4 | Total |
|------------------|----------|----------|----------|-------|----------|
| Original Billed: | 2,722.00 | 2,722.00 | 2,855.94 | 0.00 | 8,299.94 |
| Payments: | 2,722.00 | 2,722.00 | 0.00 | 0.00 | 5,444.00 |
| Balance: | 0.00 | 0.00 | 2,855.94 | 0.00 | 2,855.94 |

| Date | Qtr | Type | Code | Check No | Mthd | Reference | Batch Id | Principal | Interest | 2022 Prin Balance |
|----------|-----|-----------|------|----------|------|------------|----------|-----------|----------|-------------------|
| | | | | | | | | 8,299.94 | | 8,299.94 |
| 02/07/22 | 1 | Payment | 005 | WIRE | CK | 24329 3928 | F37NATM | 2,722.00 | 0.00 | 5,577.94 |
| | | CORELOGIC | | | | | | | | |
| 05/04/22 | 2 | Payment | 005 | WIRE | CK | 24769 3980 | 024NATM | 2,722.00 | 0.00 | 2,855.94 |
| | | CORELOGIC | | | | | | | | |

Total Principal Balance for Tax Years in Range: 2,855.94

Lien

BLQ: 4905, 20
Owner Name: 35 ORCHARD REALTY LLC

Tax Year: 2022 to 2022
Property Location: 35 ORCHARD ST

| Tax Year: 2022 | Qtr 1 | Qtr 2 | Qtr 3 | Qtr 4 | Total |
|------------------|----------|----------|----------|-------|----------|
| Original Billed: | 2,348.00 | 2,348.00 | 2,356.00 | 0.00 | 7,052.00 |
| Payments: | 2,348.00 | 2,344.48 | 0.00 | 0.00 | 4,692.48 |
| Balance: | 0.00 | 3.52 | 2,356.00 | 0.00 | 2,359.52 |

| Date | Qtr | Type | Code | Check No | Mthd | Reference | Batch Id | Principal | Interest | 2022 Prin Balance | |
|----------|-----|----------------------|------|-----------|------|-----------|------------|-----------|----------|-------------------|--|
| | | | | | | | | 7,052.00 | | 7,052.00 | |
| 02/23/22 | 1 | Payment | 006 | 53069 | CK | 24417 | 6 F97SUBS | 2,348.00 | 25.83 | 4,704.00 | |
| | | Original Billed | | | | | | | | | |
| | | ACTLIEN HOLDING INC. | | | | | | | | | |
| 05/23/22 | 2 | Payment | 006 | 54507 L/H | CK | 24896 | 5 M097SUBS | 2,344.48 | 25.83 | 2,359.52 | |
| | | ACTLIEN HOLDING, INC | | | | | | | | | |

Total Principal Balance for Tax Years in Range: 2,359.52

Miscellaneous Payments for Date Range 01/01/22 to 12/31/22:

| Date | Type | Code | Check No | Mthd | Reference | Batch Id | Principal | Interest | Total |
|----------|---------------|------|----------|------|-----------|--------------|-----------|----------|------------------|
| 01/13/22 | Payment | 907 | | CK | 24189 | 208 TAX SALE | 47,100.00 | 0.00 | 47,100.00 |
| | TAX SALE | | | | | | | | |
| 01/13/22 | Payment | 908 | | CK | 24189 | 207 TAX SALE | 0.00 | 148.74 | 148.74 |
| | TAX SALE COST | | | | | | | | |
| | | | | | | | | | <u>47,248.74</u> |

*Lien current
per tax collector
on 7/19/22*

BLQ: 4905. 21.
Owner Name: HOWARD, BEN C. & MELISSA B.

Tax Year: 2022 to 2022
Property Location: 43 ORCHARD ST

| Tax Year: 2022 | Qtr 1 | Qtr 2 | Qtr 3 | Qtr 4 | Total |
|------------------|----------|----------|----------|-------|----------|
| Original Billed: | 1,976.00 | 1,976.00 | 1,981.23 | 0.00 | 5,933.23 |
| Payments: | 1,976.00 | 1,976.00 | 0.04 | 0.00 | 3,952.04 |
| Balance: | 0.00 | 0.00 | 1,981.19 | 0.00 | 1,981.19 |

| Date | Qtr | Type | Code | Check No | Mthd | Reference | Batch Id | Principal | Interest | 2022 Prin Balance |
|----------|-----|---------|-----------------|----------|------|-----------|------------|-----------|----------|-------------------|
| | | | Original Billed | | | | | 5,933.23 | | 5,933.23 |
| 03/14/22 | 1 | Payment | 005 | 1242 | CK | 24527 | 20 045NATM | 1,976.00 | 24.56 | 3,957.23 |
| | | HOWARD | | | | | | | | |
| 03/14/22 | 2 | Payment | 005 | 1242 | CK | 24527 | 21 045NATM | 9.15 | 0.00 | 3,948.08 |
| | | HOWARD | | | | | | | | |
| 05/19/22 | 2 | Payment | 005 | | CS | 24882 | 13 085JESS | 0.00 | 3.96 | 3,948.08 |
| | | HOWARD | | | | | | | | |
| 05/19/22 | 2 | Payment | 005 | 1258 | CK | 24882 | 14 085JESS | 1,966.85 | 6.24 | 1,981.23 |
| | | HOWARD | | | | | | | | |
| 05/19/22 | 3 | Payment | 005 | | CS | 24882 | 12 085JESS | 0.04 | 0.00 | 1,981.19 |
| | | HOWARD | | | | | | | | |

Total Principal Balance for Tax Years in Range: 1,981.19

BLQ: 4905. 22.01
Owner Name: MCKENZIE, DIMIAN & SHAREE

Tax Year: 2022 to 2022
Property Location: 1335 GRAHAM PL

| Tax Year: 2022 | Qtr 1 | Qtr 2 | Qtr 3 | Qtr 4 | Total |
|------------------|----------|----------|----------|-------|-----------|
| Original Billed: | 3,516.00 | 3,516.00 | 3,526.13 | 0.00 | 10,558.13 |
| Payments: | 3,516.00 | 3,516.00 | 0.00 | 0.00 | 7,032.00 |
| Balance: | 0.00 | 0.00 | 3,526.13 | 0.00 | 3,526.13 |

| Date | Qtr | Type | Code | Check No | Mthd | Reference | Batch Id | Principal | Interest | 2022 Prin Balance |
|----------|-----|-----------|------|----------|------|------------|----------|-----------|----------|-------------------|
| | | | | | | | | 10,558.13 | | 10,558.13 |
| 02/07/22 | 1 | Payment | 005 | WIRE | CK | 24329 3929 | F37NATM | 3,516.00 | 0.00 | 7,042.13 |
| | | CORELOGIC | | | | | | | | |
| 05/04/22 | 2 | Payment | 005 | WIRE | CK | 24769 3981 | 024NATM | 3,516.00 | 0.00 | 3,526.13 |
| | | CORELOGIC | | | | | | | | |

Total Principal Balance for Tax Years in Range: 3,526.13

Appendix C:

Municipal Records: Health Department

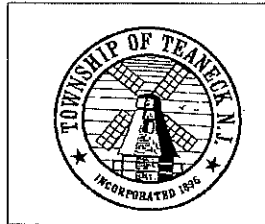

TEANECK HEALTH DEPARTMENT
 818 TEANECK ROAD
 TEANECK, NEW JERSEY 07666
 (201) 837-1600 ext. 1500

File

NOTICE OF VIOLATION

*Extension granted
9/20/21*

Sent Certified and Regular Mail

Date: 08/ 26 / 21

Re: 61 Graham Place, Teaneck, NJ 07666 (block 4905, lot 1)
 Name: Peter Draskin
 Mailing Address: Same

Abated

YOU ARE HEREBY NOTIFIED TO HAVE THE FOLLOWING CONDITION(S) REMEDIATED WITHIN (10) DAYS.

Section(s):

Violation(s):

- | | | |
|------------|----|--|
| 19 - 15 | xx | - Remove junk, garbage and debris from the entire property. |
| 19 - 16** | xx | - Remove overgrowth and other matter from the entire property. |
| 29a-12 g 1 | xx | -No motor vehicle which in unregistered or in a state of disrepair shall be parked or stored on any property in any residential zone, unless said vehicle is completely covered with a commercially available opaque vehicle cover. Please repair/remove, register or cover the parked vehicles in your driveway. |
| 19-17 | xx | -Wherever the owner or tenant shall have refused or neglected to remove the nuisance or fire hazard in the manner and within the time provided in Section 19-16, the Township Manager is authorized to provide for the removal of the same. |

Re-inspection date on or after: 09 / 08 / 21

****FAILURE TO COMPLY MAY RESULT IN ENFORCEMENT ACTIONS BY THE TOWNSHIP INCLUDING THE ISSUANCE OF SUMMONS(ES) WITH A PENALTY OF UP TO \$500.00 PER CITATION AND/OR ABATEMENT OF THE VIOLATION(S) BY THE TOWNSHIP AT THE EXPENSE OF THE PROPERTY OWNER AND/OR RESPONSIBLE PARTY. THE COST OF THE ABATEMENT MAY GO UP TO \$2,500. THESE COST WILL BE APPLIED TO LABOR, OVER-TIME, EQUIPMENT, DUMPING/REMOVAL COSTS AND/OR LEGAL COSTS. THIS ACTION IS NECESSARY AS A PUBLIC HEALTH MEASURE (201) 837-1600 Ext. 1508 OR NWONG@TEANECKNJ.GOV. IF YOU DESIRE A HEARING, YOU MUST CONTACT THE TEANECK HEALTH DEPT. PRIOR TO THE REMEDIATED TIME NOTED ABOVE.**

*Tenant Christal
201-917-8672*

**Nelson O. Wong
 Environmental Health Specialist
 Teaneck Health Department**



Teaneck Township
Complaint Response Form

Date Created: 8/25/2021
Date Received: 8/25/2021
Time Received: 1:30:20 PM
Tracking Number:
CPT-21-00337

Complaint:

Municipality: Teaneck Township Category: Complaint
Department Origin: CodeEnforcement Complaint Type: Property Maintenance
User Origin: Nelson Wong Status: Pending
Assigned to Department: CodeEnforcement Priority: Normal
Assign to User: Nelson Wong Method Received: Phone
Private: No

Complaint Summary:

Overgrowth, littered, junk vehicles in the driveway, 3 dogs?, property not maintained.

Complaint Result:

Location: 61 GRAHAM PL
Street Address 1: 61 GRAHAM PL
Street Address 2: _____
City: Teaneck Township State: NJ Zip: _____ - _____
Block: 4905 Lot: 1 Qualifier: _____

Owner: DRASKIN, PETER
Street Address 1: 61 GRAHAM PL
Street Address 2: _____
City: TEANECK State: NJ Zip: 07666 - _____
Telephone: _____ Cellphone: _____
Email: _____

Tenant: _____
Street Address 1: _____
Street Address 2: _____
City: _____ State: NJ Zip: _____ - _____
Telephone: _____ Cellphone: _____
Email: _____

Complaint Submitted By:

First Name: _____ Last Name: _____
Street Address 1: _____
Street Address 2: _____
City: _____ State: _____ Zip: _____ - _____
Telephone: _____ Cellphone: _____

Complaint Notes:

0260 SC 006209

Municipal Court of Teaneck
Municipal Bldg.
Cedar Lane & Teaneck Rd.
Teaneck, NJ 07666

The State of New Jersey
VS.

Defendant's Name: First Initial Last
Peter Druskin

Address
213 LAWTON AVE CLATSIDE PARK

State Zip Code Telephone
NJ 07010

Birth Date: Mo. Day Yr. Sex Eyes Color Height Restrictions
12 11 2015 10:30 AM

Driver's License #
State Exp. Date

STATE OF NEW JERSEY COUNTY OF BERGEN JSS:

Complaining Witness: *Curtis E. Lawrence*
(Name)
of *Teaneck Health Dept*
(Identify Dept/Agency Represented) (Badge No.)
Residing at *818 TEANECK RD, TEANECK, NJ*

COMPLAINANT

by certification or on oath, says that to the best of his/her knowledge or information and belief, the named defendant on or about the *12 11 2015 10:30 AM* in *TEANECK* *0260* County of *BERGEN* N.J. did commit the following offense:

Failed to maintain property by allowing inoperable vehicles
29A-12(a)(1)

in violation of (one charge only) (Statute, Regulation or Ordinance Number)

LOCATION OF OFFENSE Describe Location
6 Graham PL

OATH: Subscribed and sworn to before me this _____ day of _____, yr _____

CERTIFICATION: I certify that the foregoing statements made by me are true. I am aware that if any of the foregoing statements made by me are willfully false, I am subject to punishment.

OR
12/11/15 (Date)
Curtis E. Lawrence (Signature of Complaining Witness)

(Signature of Complaining Witness)
(Signature of Person Administering Oath)

PROBABLE CAUSE DETERMINATION FOR ISSUANCE OF PROCESS:

| COURT USE ONLY | LAW ENFORCEMENT USE ONLY |
|---|--|
| Probable cause is found for the issuance of this Complaint-Summons <input type="checkbox"/> Yes <input type="checkbox"/> No (Signature of Judicial Officer) <input type="checkbox"/> Yes <input type="checkbox"/> No (Signature of Judge) | <input type="checkbox"/> The complaining witness is a law enforcement officer and a judicial probable cause determination is not required prior to the issuance of this Complaint-Summons. |

SUMMONS

YOU ARE HEREBY SUMMONED TO APPEAR BEFORE THIS COURT TO ANSWER THIS COMPLAINT IF YOU FAIL TO APPEAR ON THE DATE AND AT THE TIME STATED, A WARRANT MAY BE ISSUED FOR YOUR ARREST.

NOTICE TO APPEAR

COURT APPEARANCE REQUIRED
COURT DATE: *12 13 2016* Time *4:30* AM/PM

12/11/15 (Date Summons Issued)
Curtis E. Lawrence (Signature of Person Issuing Summons)

0260 SC 006209

Municipal Court of Teaneck
Municipal Bldg.
Cedar Lane & Teaneck Rd.
Teaneck, NJ 07666

The State of New Jersey
VS.

Defendant's Name: First Initial Last
Peter Druskin

Address
213 LAWTON AVE CLATSIDE PARK

State Zip Code Telephone
NJ 07010

Birth Date: Mo. Day Yr. Sex Eyes Color Height Restrictions
12 11 2015 10:30 AM

Driver's License #
State Exp. Date

STATE OF NEW JERSEY COUNTY OF BERGEN JSS:

Complaining Witness: *Curtis E. Lawrence*
(Name)
of *Teaneck Health Dept*
(Identify Dept/Agency Represented) (Badge No.)
Residing at *818 TEANECK RD, TEANECK, NJ*

COMPLAINANT

by certification or on oath, says that to the best of his/her knowledge or information and belief, the named defendant on or about the *12 11 2015 10:30 AM* in *TEANECK* *0260* County of *BERGEN* N.J. did commit the following offense:

Failed to maintain property by allowing inoperable vehicles
29A-12(a)(1)

in violation of (one charge only) (Statute, Regulation or Ordinance Number)

LOCATION OF OFFENSE Describe Location
6 Graham PL

OATH: Subscribed and sworn to before me this _____ day of _____, yr _____

CERTIFICATION: I certify that the foregoing statements made by me are true. I am aware that if any of the foregoing statements made by me are willfully false, I am subject to punishment.

OR
12/11/15 (Date)
Curtis E. Lawrence (Signature of Complaining Witness)

(Signature of Complaining Witness)
(Signature of Person Administering Oath)

PROBABLE CAUSE DETERMINATION FOR ISSUANCE OF PROCESS:

| COURT USE ONLY | LAW ENFORCEMENT USE ONLY |
|---|--|
| Probable cause is found for the issuance of this Complaint-Summons <input type="checkbox"/> Yes <input type="checkbox"/> No (Signature of Judicial Officer) <input type="checkbox"/> Yes <input type="checkbox"/> No (Signature of Judge) | <input type="checkbox"/> The complaining witness is a law enforcement officer and a judicial probable cause determination is not required prior to the issuance of this Complaint-Summons. |

SUMMONS

YOU ARE HEREBY SUMMONED TO APPEAR BEFORE THIS COURT TO ANSWER THIS COMPLAINT IF YOU FAIL TO APPEAR ON THE DATE AND AT THE TIME STATED, A WARRANT MAY BE ISSUED FOR YOUR ARREST.

NOTICE TO APPEAR

COURT APPEARANCE REQUIRED
COURT DATE: *12 13 2016* Time *4:30* AM/PM

12/11/15 (Date Summons Issued)
Curtis E. Lawrence (Signature of Person Issuing Summons)

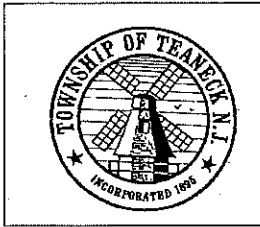

TEANECK HEALTH DEPARTMENT

818 TEANECK ROAD
TEANECK, NEW JERSEY 07666
(201) 837-1600 ext. 1500

File

NOTICE OF VIOLATION

Date: 04/ 27 / 22

Re: 54 West Englewood Avenue, Teaneck, NJ 07666 (block 4905, lot 3)
Name: Mohammed Sadiqulla
Mailing Address: 94 Jackson Drive, Cresskill, NJ 07626

YOU ARE HEREBY NOTIFIED TO HAVE THE FOLLOWING CONDITION(S) REMEDIED WITHIN (10) DAYS.

| <u>Section(s):</u> | | <u>Violation(s):</u> |
|--------------------|----|---|
| 19 - 15 | xx | - Remove junk and debris from the entire property. 10 days |
| 19 - 16** | xx | - Remove overgrowth, weeds, junk, debris or other matter from the entire property. 10 days PLEASE REMOVE LARGE ACCUMULATION OF OVERGROWTH, GARBAGE, LITTER AND JUNK FROM THE ENTIRE PROPERTY. |
| 19-17 | xx | -Wherever the owner or tenant shall have refused or neglected to remove the nuisance or fire hazard in the manner and within the time provided in Section 19-16, the Township Manager is authorized to provide for the removal of the same. |
| 29A-13, 23 | xx | Exterior is blighted, deteriorated, and/or inadequately maintained. PLEASE REPAIR EXTERIOR OF HOUSE AND GARAGE INCLUDING ROOF, GUTTER, FAÇADE, ETC. |
| 29A-33 | xx | -Exterior contains evidence of infestation. Eliminate infestation of wild animals inside house, garage and yard. |
| 29A-23.1 | xx | -All vacant buildings must be thoroughly secured so as to prevent unauthorized access and vandalism. Secure all openings from house and garage. |

Re-inspection date on or after: 05/ 10/ 22

****FAILURE TO COMPLY MAY RESULT IN ENFORCEMENT ACTIONS BY THE TOWNSHIP INCLUDING THE ISSUANCE OF SUMMONS(ES) WITH A PENALTY OF UP TO \$500.00 PER CITATION AND/OR ABATEMENT OF THE VIOLATION(S) BY THE TOWNSHIP AT THE EXPENSE OF THE PROPERTY OWNER AND/OR RESPONSIBLE PARTY. THE COST OF THE ABATEMENT MAY GO UP TO \$2,500. THESE COST WILL BE APPLIED TO LABOR, OVER-TIME, EQUIPMENT, DUMPING/REMOVAL COSTS AND/OR LEGAL COSTS. THIS ACTION IS NECESSARY AS A PUBLIC HEALTH MEASURE (201) 837-1600 Ext. 1508 OR NWONG@TEANECKNJ.GOV. IF YOU DESIRE A HEARING, YOU MUST CONTACT THE TEANECK HEALTH DEPT. PRIOR TO THE REMEDIED TIME NOTED ABOVE.**

**Nelson O. Wong
Environmental Health Specialist
Teaneck Health Department**

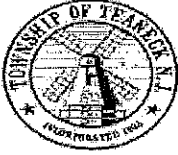

Teaneck Township
Complaint Response Form

Date Created: 4/21/2022
 Date Received: 4/21/2022
 Time Received: 12:48:32 PM
 Tracking Number:
CPT-22-00361

Complaint:

Municipality: Teaneck Township Category: Complaint
 Department Origin: CodeEnforcement Complaint Type: Property Maintenance
 User Origin: Curtis Caviness Status: Pending
 Assigned to Department: CodeEnforcement Priority: Normal
 Assign to User: Nelson Wong Method Received: Phone
 Private: No

Complaint Summary:

54 Englewood Ave has garbage, etc. throughout the properties. Rodents seen.

Complaint Result:

Location: 54 W ENGLEWOOD AVE
 Street Address 1: 54 W ENGLEWOOD AVE
 Street Address 2:
 City: Teaneck Township State: NJ Zip: _____ - _____
 Block: 4905 Lot: 3 Qualifier: _____

Owner: SADIQUILLA, MOHAMMED
 Street Address 1: 94 JACKSON DRIVE
 Street Address 2:
 City: CRESSKILL State: NJ Zip: 07626 - _____
 Telephone: _____ Cellphone: _____
 Email: _____

Tenant:
 Street Address 1:
 Street Address 2:
 City: _____ State: NJ Zip: _____ - _____
 Telephone: _____ Cellphone: _____
 Email: _____

Complaint Submitted By:

First Name: dimain Last Name: mckensie
 Street Address 1: 1335 graham place
 Street Address 2:
 City: teaneck State: NJ Zip: 07666 - _____
 Telephone: (646) 244-5857 Cellphone: _____

Complaint Notes:



Teaneck Township
Complaint Response Form

Date Created: 11/15/2021
 Date Received: 11/15/2021
 Time Received: 12:30:12 PM
 Tracking Number:
CPT-21-00508

Complaint:

Municipality: Teaneck Township Category: Complaint
 Department Origin: CodeEnforcement Complaint Type: Property Maintenance
 User Origin: Fausto Garcia Status: Reviewed
 Assigned to Department: CodeEnforcement Priority: Normal
 Assign to User: Nelson Wong Method Received: Phone
 Private: No

Complaint Summary:

Property is not being maintained litter and garbage in property has observed wildlife groundhogs and deer

Complaint Result:

I called the owner on 11/18/21.
 Mr. Mohammed will do the cleaning and hire a animal control for the groundhogs. I will follow up after November 29 and issue summonses if necessary.

Location: 54 W ENGLEWOOD AVE

Street Address 1: 54 W ENGLEWOOD AVE
 Street Address 2:
 City: Teaneck Township State: NJ Zip: _____ - _____
 Block: 4905 Lot: 3 Qualifier: _____

Owner: SADIQULLA, MOHAMMED

Street Address 1: 94 JACKSON DRIVE
 Street Address 2:
 City: CRESSKILL State: NJ Zip: 07626 - _____
 Telephone: _____ Cellphone: _____
 Email: _____

Tenant:

Street Address 1:
 Street Address 2:
 City: _____ State: NJ Zip: _____ - _____
 Telephone: _____ Cellphone: _____
 Email: _____

Complaint Submitted By:

First Name: anna Last Name: gazumyan
 Street Address 1: 44 w englewood ave
 Street Address 2:
 City: teaneck State: NJ Zip: 07666 - _____
 Telephone: (646) 734-0709 Cellphone: _____

Complaint Notes:

Complaint

10/6/21

PAID \$54⁰⁰
 lieu of a court
 appearance. NW

The State of New Jersey

(Please Print) **VS.**

Defendant's Name: First Initial Last
MOHAMMED SADIQUILLA

Address
94 Jackson Drive Creskill

State Zip Code Telephone:
NJ 07626

Birth Date: Mo. Day Yr. Sex Eyes Height Restrictions
 #

DL #

State Exp. Date

STATE OF NEW JERSEY
 COUNTY OF **BERGEN** } SS:

Complaining Witness: **Nelson Wong**
 of **Teaneck Health Dept.**

Residing at **818 Teaneck Rd Teaneck NJ 07666**
 by certification or on oath, says that to the best of his/her knowledge or
 information and belief, the named defendant on or about the
03 09 2021 1pm

in **TEANECK TOWNSHIP 0260** County of **BERGEN NJ**

did commit the following offense:
FAILURE TO REMOVE GARBAGE FROM PROPERTY 19-15
 (DESCRIPTION OF OFFENSE)
 in violation of (one charge only)

LOCATION OF OFFENSE **COBEN W. Englewood Ave Teaneck**
 (Describe Location)

OATH: Subscribed and sworn to before
 me this ___ day of ___, yr. _____
 (Signature of Complaining Witness) **OR** **08/09/21**
 (Signature of Person Administering Oath) **Nelson Wong**
 (Signature of Complaining Witness)

PROBABLE CAUSE DETERMINATION FOR ISSUANCE OF PROCESS:

| COURT USE ONLY | LAW / CODE ENFORCEMENT USE ONLY |
|--|--|
| Probable cause is found for the issuance Of this Complaint-Summons <input type="checkbox"/> Yes <input type="checkbox"/> No (Signature of Judicial Officer) <input type="checkbox"/> Yes <input type="checkbox"/> No (Signature of Judge) | <input checked="" type="checkbox"/> The complaining witness is a law enforcement officer or a code enforce- ment officer with territorial and subject matter jurisdiction and a judicial prob- able cause determination is not re- quired prior to the issuance of this Complaint-Summons. |

YOU ARE HEREBY SUMMONED TO APPEAR
 BEFORE THIS COURT TO ANSWER THIS COMPLAINT. IF YOU FAIL TO APPEAR ON THE
 DATE AND AT THE TIME STATED, A WARRANT MAY BE ISSUED FOR YOUR ARREST.

NOTICE TO APPEAR

COURT APPEARANCE REQUIRED

COURT DATE: **10 08 21 9 30 AM**

COMPLAINT

COMPLAINT

SUMMONS

SUMMONS

COURT I.D. PREFIX COMPLAINT NUMBER
0260 - SC - 010300

TEANECK TOWNSHIP
 MUNICIPAL COURT
 818 Teaneck Road
 Teaneck, NJ 07666

Complaint

The State of New Jersey

(Please Print) VS.
 Defendant's Name: First Initial Last
MOHAMMED SADIQUILLA
 Address City
94 JACKSON DRIVE CRESSKILL
 State Zip Code Telephone:
NJ 07626
 Birth Date: Mo. Day Yr. Sex Eyes Height Restrictions
 DL # State Exp. Date

STATE OF NEW JERSEY COUNTY OF **BERGEN** } SS:
 Complaining Witness: **Nelson Wong**
 of **TEANECK HEALTH DEPT.**
 Residing at **818 TEANECK RD., TEANECK, NJ 07666**
 by certification or on oath, says that to the best of his/her knowledge or information and belief, the named defendant on or about the **08 09 2021** **1pm**
 in **TEANECK TOWNSHIP 0260** County of **BERGEN** NJ

did commit the following offense:
FAILURE TO REMOVE OVERGROWTH. (DESCRIPTION OF OFFENSE)
19-16 (Statute, Regulation or Ordinance Number)

LOCATION OF OFFENSE **COBEN/W. ENGLEWOOD AVE TEANECK**
 OATH: Subscribed and sworn to before me this _____ day of _____, yr. _____
 CERTIFICATION: I certify that the foregoing statements made by me are true. I am aware that if any of the foregoing statements made by me are willfully false, I am subject to punishment.
 OR **08/09/21**
 (Signature of Complaining Witness) (Date) (Signature of Person Administering Oath) (Signature of Complaining Witness)

PROBABLE CAUSE DETERMINATION FOR ISSUANCE OF PROCESS:

| COURT USE ONLY | LAW / CODE ENFORCEMENT USE ONLY |
|---|--|
| Probable cause is found for the issuance of this Complaint-Summons <input type="checkbox"/> Yes <input checked="" type="checkbox"/> No (Signature of Judicial Officer) <input type="checkbox"/> Yes <input checked="" type="checkbox"/> No (Signature of Judge) | <input checked="" type="checkbox"/> The complaining witness is a law enforcement officer or a code enforcement officer with territorial and subject matter jurisdiction and a judicial probable cause determination is not required prior to the issuance of this Complaint-Summons. |

YOU ARE HEREBY SUMMONED TO APPEAR
 BEFORE THIS COURT TO ANSWER THIS COMPLAINT. IF YOU FAIL TO APPEAR ON THE DATE AND AT THE TIME STATED, A WARRANT MAY BE ISSUED FOR YOUR ARREST.
NOTICE TO APPEAR
 COURT APPEARANCE REQUIRED
 COURT DATE **9 8 21 9 30 AM**
8/9/21 (Date Summons Issued) **Nelson O. Wong** (Signature of Person Issuing Summons)

10/6/21
 PAID \$54
 IN LIEU OF A COURT APPEARANCE
 NW

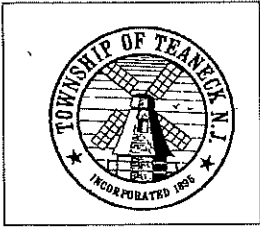

TEANECK HEALTH DEPARTMENT

818 TEANECK ROAD
TEANECK, NEW JERSEY 07666
(201) 837-1600 ext. 1500

FD 19

NOTICE OF VIOLATION

Not All done
07/27/21

Sent Certified and Regular Mail

Date:

Re: 54 West Englewood Avenue, Teaneck, NJ 07666 (block 4905, lot 3)
Name: Mohammed Sadiqulla
Mailing Address: 94 Jackson Drive, Cresskill, NJ 07626

YOU ARE HEREBY NOTIFIED TO HAVE THE FOLLOWING CONDITION(S) REMEDIED WITHIN (10) DAYS.

| <u>Section(s):</u> | <u>Violation(s):</u> |
|--------------------|---|
| 19 - 15 xx | - Remove junk and debris from the entire property. |
| 19 - 16** xx | - Remove overgrowth, weeds, junk, debris or other matter from the entire property. |
| 29A - 15 xx | - Maintain landscaping, bushes, hedges, etc. |
| 29A-23 xx | -Exterior contains evidence of infestation. Eliminate infestation. Please treat lot for mosquitos and insect infestation. Call B.C. Mosquito Commission at 201-634-2881. |
| 19-17 xx | - Wherever the owner or tenant shall have refused or neglected to remove the nuisance or fire hazard in the manner and within the time provided in Section 19-16, the Township Manager is authorized to provide for the removal of the same. |

Re-inspection date on or after: 08 / 09 / 21

****FAILURE TO COMPLY MAY RESULT IN ENFORCEMENT ACTIONS BY THE TOWNSHIP INCLUDING THE ISSUANCE OF SUMMONS(ES) WITH A PENALTY OF UP TO \$500.00 PER CITATION AND/OR ABATEMENT OF THE VIOLATION(S) BY THE TOWNSHIP AT THE EXPENSE OF THE PROPERTY OWNER AND/OR RESPONSIBLE PARTY. THE COST OF THE ABATEMENT MAY GO UP TO \$2,500. THESE COST WILL BE APPLIED TO LABOR, OVER-TIME, EQUIPMENT, DUMPING/REMOVAL COSTS AND/OR LEGAL COSTS. THIS ACTION IS NECESSARY AS A PUBLIC HEALTH MEASURE (201) 837-1600 Ext. 1508 OR NWONG@TEANECKNJ.GOV. IF YOU DESIRE A HEARING, YOU MUST CONTACT THE TEANECK HEALTH DEPT. PRIOR TO THE REMEDIED TIME NOTED ABOVE.**

**Nelson O. Wong
Environmental Health Specialist
Teaneck Health Department**

cc: 652 Glenwood Avenue, Teaneck, NJ 07666



.....

.....

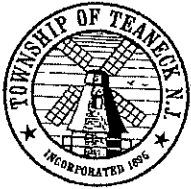

TEANECK HEALTH DEPARTMENT

818 TEANECK ROAD
TEANECK, NEW JERSEY 07666
(201) 837-1600 ext. 1500

File

NOTICE OF VIOLATION

Sent Certified and Regular Mail

Date: 07/ 27 / 21

Re: 54 West Englewood Avenue, Teaneck, NJ 07666 (block 4905, lot 3)
Name: Mohammed Sadiqulla
Mailing Address: 94 Jackson Drive, Cresskill, NJ 07626

YOU ARE HEREBY NOTIFIED TO HAVE THE FOLLOWING CONDITION(S) REMEDIED WITHIN (10) DAYS.

| <u>Section(s):</u> | <u>Violation(s):</u> |
|--------------------|---|
| 19 – 15 xx | - Remove junk and debris from the entire property. |
| 19 - 16** xx | - Remove overgrowth, weeds, junk, debris or other matter from the entire property. |
| 29A – 15 xx | - Maintain landscaping, bushes, hedges, etc. |
| 29A-23 xx | -Exterior contains evidence of infestation. Eliminate infestation. Please treat lot for mosquitos and insect infestation. Call B.C. Mosquito Commission at 201-634-2881. |
| 19-17 xx | - Wherever the owner or tenant shall have refused or neglected to remove the nuisance or fire hazard in the manner and within the time provided in Section 19-16, the Township Manager is authorized to provide for the removal of the same. |

Re-inspection date on or after: 08 / 09 / 21

****FAILURE TO COMPLY MAY RESULT IN ENFORCEMENT ACTIONS BY THE TOWNSHIP INCLUDING THE ISSUANCE OF SUMMONS(ES) WITH A PENALTY OF UP TO \$500.00 PER CITATION AND/OR ABATEMENT OF THE VIOLATION(S) BY THE TOWNSHIP AT THE EXPENSE OF THE PROPERTY OWNER AND/OR RESPONSIBLE PARTY. THE COST OF THE ABATEMENT MAY GO UP TO \$2,500. THESE COST WILL BE APPLIED TO LABOR, OVER-TIME, EQUIPMENT, DUMPING/REMOVAL COSTS AND/OR LEGAL COSTS. THIS ACTION IS NECESSARY AS A PUBLIC HEALTH MEASURE (201) 837-1600 Ext. 1508 OR NWONG@TEANECKNJ.GOV. IF YOU DESIRE A HEARING, YOU MUST CONTACT THE TEANECK HEALTH DEPT. PRIOR TO THE REMEDIED TIME NOTED ABOVE.**

**Nelson O. Wong
Environmental Health Specialist
Teaneck Health Department**



Teaneck Township
Complaint Response Form

Date Created: 7/26/2021
 Date Received: 7/26/2021
 Time Received: 12:57:36 PM
 Tracking Number: CPT-21-00227

Complaint:

Municipality: Teaneck Township Category: Complaint
 Department Origin: HealthPro Complaint Type: Property Maintenance
 User Origin: Jennifer Jackson Status: Pending
 Assigned to Department: CodeEnforcement Priority: Normal
 Assign to User: Nelson Wong Method Received: Phone
 Private: No

Complaint Summary:

Caller reports property overgrown, abandon, and the presence of mosquitos, various wildlife and rodents.
 Caller further notes that she has previous complained about this location.

Complaint Result:

Complaint is valid. Property not maintained. Will ask for a summary abatement on 8/9/21. Court summons to the new owner will also be issued at that time. *Violation Notice Issued on 7/27/21*

Location:

Street Address 1: 54 West Englewood Avenue
 Street Address 2: _____
 City: Teaneck State: NJ Zip: 07666 - _____
 Block: _____ Lot: _____ Qualifier: _____

Owner:

Street Address 1: _____
 Street Address 2: _____
 City: _____ State: NJ Zip: _____ - _____
 Telephone: _____ Cellphone: _____
 Email: _____

Tenant:

Street Address 1: _____
 Street Address 2: _____
 City: _____ State: NJ Zip: _____ - _____
 Telephone: _____ Cellphone: _____
 Email: _____

Complaint Submitted By:

First Name: Anna Last Name: _____
 Street Address 1: _____
 Street Address 2: _____
 City: _____ State: NJ Zip: _____ - _____
 Telephone: (646) 734-0709 Cellphone: _____

Complaint Notes:

New Search Assessment Postcard Property Card

| | | | |
|-------------------------------|------------------------------|---------------------------------|---------------------------------|
| Block: 4905 | Prop Loc: 54 W ENGLEWOOD AVE | Owner: SADIQULLA, MOHAMMED | Square Ft: 2119 |
| Lot: 3 | District: 0260 TEANECK | Street: 94 JACKSON DRIVE | Year Built: 1909 |
| Qual: | Class: 2 | City State: CRESSKILL, NJ 07626 | Style: SC |
| Additional Information | | | |
| Prior Block: | Acct Num: 045336 | Add Lots: | EPL Code: 0 0 0 |
| Prior Lot: | Mtg Acct: | Land Desc: 106X145 | Statute: |
| Prior Qual: | Bank Code: 0 | Bldg Desc: 2S-AL-O-1UG | Initial: 000000 Further: 000000 |
| Updated: 11/02/18 | Tax Codes: | Class4Cd: 0 | Desc: |
| Zone: R01 | Map Page: | Acreage: 0.3528 | Taxes: 11435.42 / 11530.90 |
| Sale Information | | | |
| Sale Date: 10/10/18 | Book: 3095 | Page: 2360 | Price: 250000 NU#: 31 |

| Sr1a | Date | Book | Page | Price | NU# | Ratio | Grantee |
|---------------------------|----------|------|------|--------|-----|--------|----------------------------------|
| More Info | 11/22/96 | 7948 | 921 | 108000 | 12 | 167.50 | NJ KCD REALTY LLC |
| More Info | 04/23/97 | 7968 | 365 | 150000 | 13 | 120.60 | D'ANGELONES, MARTA G. & EMANUELE |
| More Info | 06/12/18 | 3039 | 2317 | 100 | 12 | 0 | NATIONSTAR MORTGAGE LLC |
| More Info | 10/10/18 | 3095 | 2360 | 250000 | 31 | 141.44 | SADIQULLA, MOHAMMED |

TAX-LIST-HISTORY

| Year | Property Location | Land/Imp/Tot | Exemption | Assessed | Property Class |
|-------------|--------------------|--------------|-----------|----------|----------------|
| <u>2021</u> | 54 W ENGLEWOOD AVE | 166600 | 0 | 353600 | 2 |
| | | 187000 | | | |
| | | 353600 | | | |
| <u>2020</u> | 54 W ENGLEWOOD AVE | 166600 | 0 | 353600 | 2 |
| | | 187000 | | | |
| | | 353600 | | | |
| <u>2019</u> | 54 W ENGLEWOOD AVE | 166600 | 0 | 353600 | 2 |
| | | 187000 | | | |
| | | 353600 | | | |
| <u>2018</u> | 54 W ENGLEWOOD AVE | 166600 | 0 | 353600 | 2 |
| | | 187000 | | | |
| | | 353600 | | | |

*Click on Underlined Year for Tax List Page

[*Click Here for More History](#)

Re: 54 West Englewood Ave- SUMMARY ABATEMENT

From: Nelson Wong <nwong@teanecknj.gov>
To: Kevin Arahill <karahill@teanecknj.gov>
Date: 5/28/2020 3:15 PM

*Abated for tall CRAS 6/18/20
Waiting for DPW PW*

Kevin,

I received a new complaint from the police department, but I did not file a new summary abatement since there is already one pending. Please let me know when the work is done.

Thank you.

Nelson O. Wong
Registered Environmental Health Specialist
Teaneck Health Department
201-837-1600 Ext 1508

*Violation for tall CRAS Abated 6/18/20
PW*

This email and any files transmitted with it are privileged and confidential and may be considered advisory, consultative and deliberative material under OPRA. This communication is intended solely for the use of the individual or entity to whom they are addressed. If you have received this email in error, please notify the system manager. This message contains confidential information and is intended only for the individual named. If you are not the named addressee you should not disseminate, distribute or copy this email. Please notify the sender immediately by email if you have received this email by mistake, please delete this email from your system. If you are not the intended recipient you are notified that disclosing, copying, distributing or taking any action in reliance on the contents of this information is strictly prohibited.

From: Kevin Arahill <karahill@teanecknj.gov>
To: Nelson Wong <nwong@teanecknj.gov>, Mike Cassidy <mcassidy@teanecknj.gov>, Curtis Caviness <ccaviness@teanecknj.gov>
Sent: 5/28/2020 3:03 PM
Subject: Re: 54 West Englewood Ave- SUMMARY ABATEMENT

No work was completed.

Kevin Arahill, CPWM, CRP, CPO
Director Of Public Works
Township Of Teaneck
Telephone (201) 837-1600 Ext. 1701
Fax(201)692-0306

204 W. Englewood



From: Nelson Wong <nwong@teanecknj.gov>

To: Kevin Arahill <karahill@teanecknj.gov>, Mike Cassidy <mcassidy@teanecknj.gov>, Curtis Caviness <ccaviness@teanecknj.gov>

Sent: 5/28/2020 2:59 PM

Subject: 54 West Englewood Ave- SUMMARY ABATEMENT

Kevin/Mike,

On March 10, 2020 I issued a summary abatement for the above property. Please let me know if the DPW was able to do the work before today (5/28/2020) or if I need to issue another summary abatement order.

The property is currently overgrown, littered, etc.

Thank you.

Nelson O. Wong

Registered Environmental Health Specialist

Teaneck Health Department

201-837-1600 Ext 1508

This email and any files transmitted with it are privileged and confidential and may be considered advisory, consultative and deliberative material under OPRA. This communication is intended solely for the use of the individual or entity to whom they are addressed. If you have received this email in error, please notify the system manager. This message contains confidential information and is intended only for the individual named. If you are not the named addressee you should not disseminate, distribute or copy this email. Please notify the sender immediately by email if you have received this email by mistake, please delete this email from your system. If you are not the intended recipient you are notified that disclosing, copying, distributing or taking any action in reliance on the contents of this information is strictly prohibited.



TEANECK HEALTH DEPARTMENT

818 TEANECK ROAD
TEANECK, NEW JERSEY 07666
(201) 837-1600

SERVICE REQUEST

COMPLAINANT'S NAME: Police Dept DATE: 5/21/20 TIME: 11:00
RECV'D BY: _____
HOME #: _____
ADDRESS: _____ WORK #: _____

COMPLAINT: 54 W. ENGLEWOOD AVE
HIGH GRASS

Entered in log (CHECK) _____

FINDINGS: Valid

ACTION TAKEN: _____

SIGNED _____

[New Search](#) [Assessment Postcard](#) [Property Card](#)

Block: 4905 Prop Loc: 54 W ENGLEWOOD AVE Owner: SADIQUILLA, MOHAMMED Square Ft: 2119
 Lot: 3 District: 0260 TEANECK Street: 94 JACKSON DRIVE Year Built: 1909
 Qual: Class: 2 City State: CRESSKILL, NJ 07626 Style: SC

Additional Information

Prior Block: Acct Num: 045336 Addl Lots: EPL Code: 0 0 0
 Prior Lot: Mtg Acct: Land Desc: 106X145 Statute:
 Prior Qual: Bank Code: 0 Bldg Desc: 2S-AL-O-1UG Initial: 000000 Further: 000000
 Updated: 11/02/18 Tax Codes: Class4Cd: 0 Desc:
 Zone: R01 Map Page: Acreage: 0.3528 Taxes: 11304.59 / 0.00

Sale Information

Sale Date: 10/10/18 Book: 3095 Page: 2360 Price: 250000 NU#: 31

| Sr1a | Date | Book | Page | Price | NU# | Ratio | Grantee |
|---------------------------|----------|------|------|--------|-----|--------|----------------------------------|
| More Info | 11/22/96 | 7948 | 921 | 108000 | 12 | 167.50 | NJ KCD REALTY LLC |
| More Info | 04/23/97 | 7968 | 365 | 150000 | 13 | 120.60 | D'ANGELONES, MARTA G. & EMANUELE |
| More Info | 06/12/18 | 3039 | 2317 | 100 | 12 | 0 | NATIONSTAR MORTGAGE LLC |
| More Info | 10/10/18 | 3095 | 2360 | 250000 | 31 | 141.44 | SADIQUILLA, MOHAMMED |

TAX-LIST-HISTORY

| Year | Owner Information | Land/Imp/Tot | Exemption | Assessed | Property Class |
|-------------|---|----------------------------|-----------|----------|----------------|
| <u>2020</u> | SADIQUILLA, MOHAMMED 94 JACKSON DRIVE CRESSKILL, NJ 07626 | 166600 187000 353600 | 0 | 353600 | 2 |
| <u>2019</u> | SADIQUILLA, MOHAMMED 94 JACKSON DRIVE CRESSKILL, NJ 07626 | 166600 187000 353600 | 0 | 353600 | 2 |
| <u>2018</u> | D'ANGELONES, EMANUELLE 54 W ENGLEWOOD AVE TEANECK, NJ 07666 | 166600 187000 353600 | 0 | 353600 | 2 |
| <u>2017</u> | D'ANGELONES, EMANUELLE 54 W ENGLEWOOD AVE TEANECK, NJ 07666 | 166600 187000 353600 | 0 | 353600 | 2 |

*Click on Underlined Year for Tax List Page

[*Click Here for More History](#)

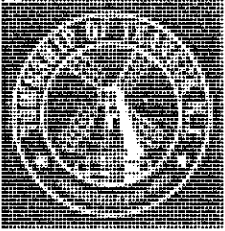

TEANECK HEALTH DEPARTMENT

818 TEANECK ROAD
TEANECK, NEW JERSEY 07666
201-837-1600 ext. 1500
Website: teanecknj.gov

SERVICE REQUEST

DATE: 8/20/2020 TIME: 1:09PM

RECV'D BY: _____ Phone _____

COMPLAINANT: Anna HOME#: 646-734-0709

ADDRESS: 44 W. Englewood Ave WORK#: _____

CELL#: _____

COMPLAINT:

54 W Englewood Ave. REPEAT vacant house overgrown with mosquitoes

Entered in log (check)

FINDINGS:

8/20/20 Valid
Summary Abatement issued on
3/10/20.

ACTION TAKEN:

E-MAIL sent to DPW

SIGNED DEC NW

Re: Summary Abatements

From: Nelson Wong <nwong@teanecknj.gov>

To: Nelson Wong <nwong@teanecknj.gov>, Travon Romeo <tromeo@teanecknj.gov>, Kevin Arahill <karahill@teanecknj.gov>, Ken Katter <kkatter@teanecknj.gov>, Curtis Caviness <ccaviness@teanecknj.gov>

Date: 8/20/2020 1:17 PM

Romeo/kevin,

Please add:

- 54 West Englewood Avenue to the list. Summary abatement order was issued on 3/10/2020.

The property is neglected again for the same exact violations.

Thank you

Ps. This could be **number 5** on the list. We get many complaints about this property.

Nelson O. Wong

Registered Environmental Health Specialist

Teaneck Health Department

201-837-1600 Ext 1508

This email and any files transmitted with it are privileged and confidential and may be considered advisory, consultative and deliberative material under OPRA. This communication is intended solely for the use of the individual or entity to whom they are addressed. If you have received this email in error, please notify the system manager. This message contains confidential information and is intended only for the individual named. If you are not the named addressee you should not disseminate, distribute or copy this email. Please notify the sender immediately by email if you have received this email by mistake, please delete this email from your system. If you are not the intended recipient you are notified that disclosing, copying, distributing or taking any action in reliance on the contents of this information is strictly prohibited.

From: Nelson Wong <nwong@teanecknj.gov>

To: Travon Romeo <tromeo@teanecknj.gov>, Kevin Arahill <karahill@teanecknj.gov>, Ken Katter <kkatter@teanecknj.gov>, Curtis Caviness <ccaviness@teanecknj.gov>

Sent: 8/20/2020 8:51 AM

Subject: Summary Abatements

Kevin/Romeo,

Please see if the following summary abatement orders can be done on the following order:

1. 8 East Walnut Street. issued 7/28/20
2. 1405 Teaneck Road, 6/12/20
3. 1137 Julia Street, 7/22/20
4. 332 Teaneck Road, 7/10/20
5. 63 Selvage Avenue. 7/14/20
6. 1615 Ardsey Court, 7/10/20

7. 1371 Teaneck Road, 7/14/20 Garbage in the back.
8. 432 Sagamore avenue, 7/10/20. Owner was supposed to call you to delay abatement.

Thank you.

Ps. Violation Notices with specific township violations are attached to each property.

Nelson O. Wong
Registered Environmental Health Specialist
Teaneck Health Department
201-837-1600 Ext 1508

This email and any files transmitted with it are privileged and confidential and may be considered advisory, consultative and deliberative material under OPRA. This communication is intended solely for the use of the individual or entity to whom they are addressed. If you have received this email in error, please notify the system manager. This message contains confidential information and is intended only for the individual named. If you are not the named addressee you should not disseminate, distribute or copy this email. Please notify the sender immediately by email if you have received this email by mistake, please delete this email from your system. If you are not the intended recipient you are notified that disclosing, copying, distributing or taking any action in reliance on the contents of this information is strictly prohibited.

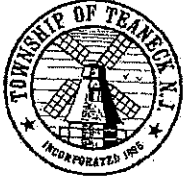

TEANECK HEALTH DEPARTMENT

818 TEANECK ROAD
TEANECK, NEW JERSEY 07666
(201) 837-1600

NW

SERVICE REQUEST

DATE: 3/3/2020 TIME: 128pm

RECV'D BY: TM

COMPLAINANT'S NAME: Anonymous

HOME #: _____

ADDRESS: _____

WORK #: _____

COMPLAINT:

54 West Englewood Avenue

garbage/litter throughout property and on the sidewalk

appears to be vacant

note: submitted on 3/5/2020

Entered in log (CHECK) x

FINDINGS:

Valid

ACTION TAKEN:

SUMMARY/ABSTRACT ISSUED 3/10/20

SIGNED _____

NW

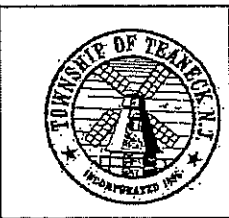

TEANECK HEALTH DEPARTMENT

818 TEANECK ROAD
TEANECK, NEW JERSEY 07666
(201) 837-1600

NO Repeat

SERVICE REQUEST

DATE: 3-10-20 TIME: 3:22pm

RECV'D BY: _____

HOME #: _____

COMPLAINANT'S NAME: _____

ADDRESS: _____

WORK #: _____

COMPLAINT:

54 West Englewood Avenue - Appears to be a house, that is used for dumping cement, wood, & all kinds of debris.

The porch is hanging, as if it will fall down at any time. The garage is loaded with garbage, & wood. The hose is abandoned but is being used to store construction debris from other job sites.

Entered in log (CHECK)

FINDINGS:

Valid

ACTION TAKEN:

SIGNED _____

[Signature]

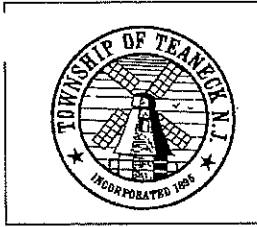

TOWNSHIP OF TEANECK
INTER-OFFICE COMMUNICATION

Copy

DATE: March 10, 2020

TO: KEN KATTER, HEALTH OFFICER

SUBJECT: 54 WEST ENGLEWOOD AVENUE - SUMMARY ABATEMENT

The owner of the above captioned address has been notified to remove violations in accordance with Township Codes 29A-13, 23, 23.1; 19-15; 19-16, 19-17. Because the owner has neglected to remove the violations within the prescribed time period, please, in accordance with the tenets of the above code direct the DPW to summarily abate the violations. (SEE ATTACHED NOTICE)

NELSON O. WONG
R.E.H.S

TO: DEAN KAZINCI - MUNICIPAL MANAGER

In accordance with the provisions of sections 29A-13, 23, 23.1; 19-15 & 19-16, 19-17, please direct the Township's DPW to correct the violations at 54 West Englewood Avenue.

KEN KATTER
HEALTH OFFICER



Summary Abatement Protocol - Property Maintenance (side #1 of 2)

Property Address: 54 West Englewood Ave Block: 4905 Lot: 3

(Health) Inspection: Inspector: Nelson Wong Date: 3/10/20

(Health) Violation Notice: Inspector: Nelson Wong Date: 9/27/19 repeat

Certified mail (noted above) sent to the following parties:

Property Owner (noted on Tax Record): Mohammed Sadigulla, 94 Jackson Drive

Other (party of interest): Cresskills, NJ 07626.

Other (party of interest): 2 yellow violation notices

Other (party of interest): posted on door & wall.

(Health) Requests Summary Abatement: (Paperwork Attached) Date: 3/10/20 ^{KK} 3-10-20

(Twp. Manager) Approval: _____ Date: _____

(DPW) Receives Approval: _____ Date: _____

(DPW) Certified Costs of Abatement: _____ Date: _____

(Health) Receipt of Costs from DPW: _____ Date: _____

(Health) Costs Mailed/Posts Property: _____ Date: _____

(DPW) Notified to Start Abatement: _____ Date: _____

(DPW) Order Executed: _____ Date: _____

(Health) Receipt of Execution from DPW: _____ Date: _____

(Health) Re-Inspects Property: _____ Date: _____

(Finance) Receives Approval to Bill: _____ Date: _____

(Finance) Sends Out Lien: _____ Date: _____

(Finance) Lien Collected: _____ Date: _____

(Twp. Mgr.) Completed: _____ Date: _____

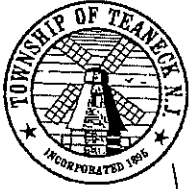

TEANECK HEALTH DEPARTMENT

818 TEANECK ROAD
TEANECK, NEW JERSEY 07666
(201) 837-1600 ext. 1500

Note:
2 yellow violation notices posted at House.

NOTICE OF VIOLATION

Repeat on 03/10/20
~~09/27/19~~

Sent Certified and Regular Mail

Date:

Re: 54 West Englewood Avenue, Teaneck, NJ 07666 (block 4905, lot 3)
Name: Mohammed Sadiqulla
Mailing Address: 94 Jackson Drive, Cresskill, NJ 07626

YOU ARE HEREBY NOTIFIED TO HAVE THE FOLLOWING CONDITION(S) REMEDIED WITHIN (10) DAYS.

Section(s):

Violation(s):

- 19 - 15 xx - Remove junk and debris from the entire property.
- 19 - 16** xx - **Remove** overgrowth, weeds, junk, debris or other matter from the entire property.
- 29A - 15 xx - Maintain landscaping, bushes, hedges, etc.
- 29A-23 xx - Exterior contains evidence of infestation. Eliminate infestation. Please treat lot for mosquitos and insect infestation. Call B.C. Mosquito Commnssion at 201-634-2881.
- 19-17 xx - **Wherever the owner or tenant shall have refused or neglected to remove the nuisance or fire hazard in the manner and within the time provided in Section 19-16, the Township Manager is authorized to provide for the removal of the same.**

Re-inspection date on or after: 10 / 08 / 19

****FAILURE TO COMPLY MAY RESULT IN ENFORCEMENT ACTIONS BY THE TOWNSHIP INCLUDING THE ISSUANCE OF SUMMONS(ES) WITH A PENALTY OF UP TO \$500.00 PER CITATION AND/OR ABATEMENT OF THE VIOLATION(S) BY THE TOWNSHIP AT THE EXPENSE OF THE PROPERTY OWNER AND/OR RESPONSIBLE PARTY. THE COST OF THE ABATEMENT MAY GO UP TO \$2,500. THESE COST WILL BE APPLIED TO LABOR, OVER-TIME, EQUIPMENT, DUMPING/REMOVAL COSTS AND/OR LEGAL COSTS. THIS ACTION IS NECESSARY AS A PUBLIC HEALTH MEASURE (201) 837-1600 Ext. 1508 OR NWONG@TEANECKNJ.GOV. IF YOU DESIRE A HEARING, YOU MUST CONTACT THE TEANECK HEALTH DEPT. PRIOR TO THE REMEDIED TIME NOTED ABOVE.**

Nelson O. Wong
Environmental Health Specialist
Teaneck Health Department









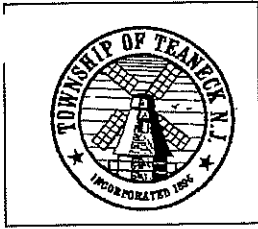

TOWNSHIP OF TEANECK
INTER-OFFICE COMMUNICATION

Copy

DATE: October 10, 2019

TO: KEN KATTER, HEALTH OFFICER

SUBJECT: 54 West Englewood Avenue - SUMMARY ABATEMENT

The owner of the above captioned address has been notified to remove violations in accordance with Township Codes 29A-13, 23, 23.1; 19-15; 19-16, 19-17. Because the owner has neglected to remove the violations within the prescribed time period, please, in accordance with the tenets of the above code direct the DPW to summarily abate the violations. (SEE ATTACHED NOTICE)

NELSON O. WONG
R.E.H.S

TO: DEAN KAZINCI - MUNICIPAL MANAGER

In accordance with the provisions of sections 29A-13, 23, 23.1; 19-15 & 19-16, 19-17, please direct the Township's DPW to correct the violations at 54 West Englewood Avenue.

KEN KATTER
HEALTH OFFICER



Summary Abatement Protocol – Property Maintenance (side #1 of 2)

Property Address: 54 West Englewood Ave Block: 4905 Lot: 3

(Health) Inspection: Inspector: Nelson Wong Date: 9/27/19

(Health) Violation Notice: Inspector: Nelson Wong Date: 9/27/19

Certified mail (noted above) sent to the following parties:

Property Owner (noted on Tax Record): Mohammed Sadigulla, 94 Jackson Drive,

Other (party of interest): Cresskill, NJ 07626.

Other (party of interest): _____

Other (party of interest): _____

(Health) Requests Summary Abatement: (Paperwork Attached) Date: 10/10/19 KK

(Twp. Manager) Approval: _____ Date: _____

(DPW) Receives Approval: _____ Date: _____

(DPW) Certified Costs of Abatement: _____ Date: _____

(Health) Receipt of Costs from DPW: _____ Date: _____

(Health) Costs Mailed/Posts Property: _____ Date: _____

(DPW) Notified to Start Abatement: _____ Date: _____

(DPW) Order Executed: _____ Date: _____

(Health) Receipt of Execution from DPW: _____ Date: _____

(Health) Re-Inspects Property: _____ Date: _____

(Finance) Receives Approval to Bill: _____ Date: _____

(Finance) Sends Out Lien: _____ Date: _____

(Finance) Lien Collected: _____ Date: _____

(Twp. Mgr.) Completed: _____ Date: _____

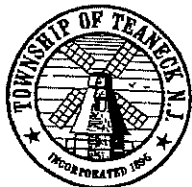

TEANECK HEALTH DEPARTMENT

818 TEANECK ROAD
TEANECK, NEW JERSEY 07666
(201) 837-1600 ext. 1500

Handwritten signature/initials

NOTICE OF VIOLATION

Sent Certified and Regular Mail

Date:

09/ 27 / 19

Re: 54 West Englewood Avenue, Teaneck, NJ 07666 (block 4905, lot 3)

Name: Mohammed Sadiqulla

Mailing Address: 94 Jackson Drive, Cresskill, NJ 07626

YOU ARE HEREBY NOTIFIED TO HAVE THE FOLLOWING CONDITION(S) REMEDIED WITHIN (10) DAYS.

Section(s):

Violation(s):

- 19 - 15 xx - Remove junk and debris from the entire property.
- 19 - 16** xx - **Remove overgrowth, weeds, junk, debris or other matter from the entire property.**
- 29A - 15 xx - Maintain landscaping, bushes, hedges, etc.
- 29A-23 xx - Exterior contains evidence of infestation. Eliminate infestation. Please treat lot for mosquitos and insect infestation. Call B.C. Mosquito Commnssion at 201-634-2881.

- 19-17 xx - **Wherever the owner or tenant shall have refused or neglected to remove the nuisance or fire hazard in the manner and within the time provided in Section 19-16, the Township Manager is authorized to provide for the removal of the same.**

Re-inspection date on or after: 10 / 08 / 19

****FAILURE TO COMPLY MAY RESULT IN ENFORCEMENT ACTIONS BY THE TOWNSHIP INCLUDING THE ISSUANCE OF SUMMONS(ES) WITH A PENALTY OF UP TO \$500.00 PER CITATION AND/OR ABATEMENT OF THE VIOLATION(S) BY THE TOWNSHIP AT THE EXPENSE OF THE PROPERTY OWNER AND/OR RESPONSIBLE PARTY. THE COST OF THE ABATEMENT MAY GO UP TO \$2,500. THESE COST WILL BE APPLIED TO LABOR, OVER-TIME, EQUIPMENT, DUMPING/REMOVAL COSTS AND/OR LEGAL COSTS. THIS ACTION IS NECESSARY AS A PUBLIC HEALTH MEASURE (201) 837-1600 Ext. 1508 OR NWONG@TEANECKNJ.GOV.
IF YOU DESIRE A HEARING, YOU MUST CONTACT THE TEANECK HEALTH DEPT. PRIOR TO THE REMEDIED TIME NOTED ABOVE.**

**Nelson O. Wong
Environmental Health Specialist
Teaneck Health Department**







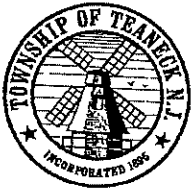

TEANECK HEALTH DEPARTMENT

818 TEANECK ROAD
TEANECK, NEW JERSEY 07666
(201) 837-1600 ext. 1500

File

NOTICE OF VIOLATION

Sent Certified and Regular Mail

Date: 09/ 27 / 19

Re: 54 West Englewood Avenue, Teaneck, NJ 07666 (block 4905, lot 3)
Name: Mohammed Sadiqulla
Mailing Address: 94 Jackson Drive, Cresskill, NJ 07626

YOU ARE HEREBY NOTIFIED TO HAVE THE FOLLOWING CONDITION(S) REMEDIED WITHIN (10) DAYS.

| <u>Section(s):</u> | <u>Violation(s):</u> |
|--------------------|---|
| 19 - 15 xx | - Remove junk and debris from the entire property. |
| 19 - 16** xx | - Remove overgrowth, weeds, junk, debris or other matter from the entire property. |
| 29A - 15 xx | - Maintain landscaping, bushes, hedges, etc. |
| 29A-23 xx | -Exterior contains evidence of infestation. Eliminate infestation. Please treat lot for mosquitos and insect infestation. Call B.C. Mosquito Commnssion at 201-634-2881. |
| 19-17 xx | - Wherever the owner or tenant shall have refused or neglected to remove the nuisance or fire hazard in the manner and within the time provided in Section 19-16, the Township Manager is authorized to provide for the removal of the same. |

Re-inspection date on or after: 10 / 08 / 19

****FAILURE TO COMPLY MAY RESULT IN ENFORCEMENT ACTIONS BY THE TOWNSHIP INCLUDING THE ISSUANCE OF SUMMONS(ES) WITH A PENALTY OF UP TO \$500.00 PER CITATION AND/OR ABATEMENT OF THE VIOLATION(S) BY THE TOWNSHIP AT THE EXPENSE OF THE PROPERTY OWNER AND/OR RESPONSIBLE PARTY. THE COST OF THE ABATEMENT MAY GO UP TO \$2,500. THESE COST WILL BE APPLIED TO LABOR, OVER-TIME, EQUIPMENT, DUMPING/REMOVAL COSTS AND/OR LEGAL COSTS. THIS ACTION IS NECESSARY AS A PUBLIC HEALTH MEASURE (201) 837-1600 Ext. 1508 OR NWONG@TEANECKNJ.GOV. IF YOU DESIRE A HEARING, YOU MUST CONTACT THE TEANECK HEALTH DEPT. PRIOR TO THE REMEDIED TIME NOTED ABOVE.**

Nelson O. Wong
Environmental Health Specialist
Teaneck Health Department



TEANECK HEALTH DEPARTMENT

818 TEANECK ROAD
TEANECK, NEW JERSEY 07666
(201) 837-1600

NW

SERVICE REQUEST

COMPLAINANT'S NAME: *Neighbor* DATE: *9/27/19* TIME: *10 AM*
REC'D BY: *NW*
ADDRESS: _____ HOME #: _____
WORK #: _____

COMPLAINT: *54 W. Englewood Ave*

Overgrown & 1st floor
etc.

Entered in log (CHECK) _____

FINDINGS:

Valid

ACTION TAKEN:

Set Violation Notice

SIGNED *NW*

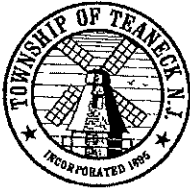

TEANECK HEALTH DEPARTMENT

818 TEANECK ROAD
TEANECK, NEW JERSEY 07666
(201) 837-1600 ext. 1500

FO
Abated
At this time sub 1/4/22
12/23/21

NOTICE OF VIOLATION

Date:

Re:

Name: 40 West Englewood Avenue, Teaneck, NJ 07666 (block 4905, lot 5)

Mailing Address: Mercy Church of God
Same

YOU ARE HEREBY NOTIFIED TO HAVE THE FOLLOWING CONDITION(S) REMEDIED WITHIN (10) DAYS.

Section(s):

Violation(s):

19 - 15 xx - Remove junk and debris from the entire property, including the sidewalk and curbside.

19 - 16** xx - **Remove** overgrowth, weeds, junk, debris or **other matter from the entire property, including dead leaves.**

19-17 xx -Wherever the owner or tenant shall have refused or neglected to remove the nuisance or fire hazard in the manner and within the time provided in Section 19-16, the Township Manager is authorized to provide for the removal of the same.

Re-inspection date on or after: 01 / 04 / 22

****FAILURE TO COMPLY MAY RESULT IN ENFORCEMENT ACTIONS BY THE TOWNSHIP INCLUDING THE ISSUANCE OF SUMMONS(ES) WITH A PENALTY OF UP TO \$500.00 PER CITATION AND/OR ABATEMENT OF THE VIOLATION(S) BY THE TOWNSHIP AT THE EXPENSE OF THE PROPERTY OWNER AND/OR RESPONSIBLE PARTY. THE COST OF THE ABATEMENT MAY GO UP TO \$2,500. THESE COST WILL BE APPLIED TO LABOR, OVER-TIME, EQUIPMENT, DUMPING/REMOVAL COSTS AND/OR LEGAL COSTS. THIS ACTION IS NECESSARY AS A PUBLIC HEALTH MEASURE (201) 837-1600 Ext. 1508 OR NWONG@TEANECKNJ.GOV. IF YOU DESIRE A HEARING, YOU MUST CONTACT THE TEANECK HEALTH DEPT. PRIOR TO THE REMEDIED TIME NOTED ABOVE.**

**Nelson O. Wong
Environmental Health Specialist
Teaneck Health Department**

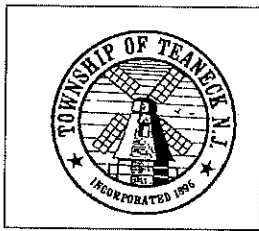

TEANECK HEALTH DEPARTMENT

818 TEANECK ROAD
TEANECK, NEW JERSEY 07666
(201) 837-1600 ext. 1500

File

NOTICE OF VIOLATION

Date: 04/ 26 / 22

Re: 26 West Englewood Avenue, Teaneck, NJ 07666 (block 4905, lot 7)
Name: 26 West Englewood LLC
Mailing Address: 492 Cedar Lane # 519, Teaneck, NJ 07666

YOU ARE HEREBY NOTIFIED TO HAVE THE FOLLOWING CONDITION(S) REMEDIED WITHIN (10) DAYS.

| <u>Section(s):</u> | <u>Violation(s):</u> |
|--------------------|---|
| 19 - 15 xx | - Remove junk and debris from the entire property. |
| 19 - 16** xx | - Remove overgrowth, weeds, junk, debris or other matter from the entire property. |
| 29A - 15 xx | - Maintain landscaping, bushes, hedges, etc. |
| 29A-23 xx | -Exterior contains evidence of infestation. Eliminate infestation. Treat property for rodents. |
| 19-17 xx | -Wherever the owner or tenant shall have refused or neglected to remove the nuisance or fire hazard in the manner and within the time provided in Section 19-16, the Township Manager is authorized to provide for the removal of the same. |

Re-inspection date on or after: 05 / 09 / 22

****FAILURE TO COMPLY MAY RESULT IN ENFORCEMENT ACTIONS BY THE TOWNSHIP INCLUDING THE ISSUANCE OF SUMMONS(ES) WITH A PENALTY OF UP TO \$500.00 PER CITATION AND/OR ABATEMENT OF THE VIOLATION(S) BY THE TOWNSHIP AT THE EXPENSE OF THE PROPERTY OWNER AND/OR RESPONSIBLE PARTY. THE COST OF THE ABATEMENT MAY GO UP TO \$2,500. THESE COST WILL BE APPLIED TO LABOR, OVER-TIME, EQUIPMENT, DUMPING/REMOVAL COSTS AND/OR LEGAL COSTS. THIS ACTION IS NECESSARY AS A PUBLIC HEALTH MEASURE (201) 837-1600 Ext. 1508 OR NWONG@TEANECKNJ.GOV. IF YOU DESIRE A HEARING, YOU MUST CONTACT THE TEANECK HEALTH DEPT. PRIOR TO THE REMEDIED TIME NOTED ABOVE.**

Nelson O. Wong
Environmental Health Specialist
Teaneck Health Department

CC: Menachen Stein, 492-C, Cedar Lane, suite 519, Teaneck, NJ 07666



Teaneck Township
Complaint Response Form

Date Created: 4/26/2022
Date Received: 4/26/2022
Time Received: 2:58:20 PM
Tracking Number: _____
CPT-22-00391

Complaint:

Municipality: Teaneck Township Category: Complaint
Department Origin: CodeEnforcement Complaint Type: Property Maintenance
User Origin: Thomas Rowe Status: Reviewed
Assigned to Department: CodeEnforcement Priority: Normal
Assign to User: Nelson Wong Method Received: Email
Private: No

Complaint Summary:

26 Englewood Ave has garbage, etc. throughout the properties. Rodents seen.

Complaint Result:

Valid

Location:

26 W ENGLEWOOD AVE

Street Address 1: 26 W ENGLEWOOD AVE
Street Address 2: _____
City: Teaneck Township State: NJ Zip: _____ - _____
Block: 4905 Lot: 7 Qualifier: _____

Owner:

26 WEST ENGLEWOOD LLC

Street Address 1: 492 CEDAR LANE #519
Street Address 2: _____
City: TEANECK State: NJ Zip: 07666 - _____
Telephone: _____ Cellphone: _____
Email: _____

Tenant:

Street Address 1: _____
Street Address 2: _____
City: _____ State: NJ Zip: _____ - _____
Telephone: _____ Cellphone: _____
Email: _____

Complaint Submitted By:

First Name: _____ Last Name: _____
Street Address 1: _____
Street Address 2: _____
City: _____ State: _____ Zip: _____ - _____
Telephone: _____ Cellphone: _____

Complaint Notes:

US MAIL SERVICE
CERTIFIED MAIL RECEIPT

IP
RT
ad
66

For delivery information, visit our website at www.usps.com

OFFICIAL USE

Certified Mail Fee \$
 Extra Services & Fees (check box, add fee as appropriate)
 Return Receipt (hardcopy) \$
 Return Receipt (electronic) \$
 Certified Mail Restricted Delivery \$
 Adult Signature Required \$
 Adult Signature Restricted Delivery \$
 Postage \$
 Total Postage and Fees \$
 Sent To: MENACHEN STEEP
 Street and Apt. No., or PO Box No. 492-C Cedar Lane # 519
 City, State, ZIP+4® Teaneck NJ 07661
 PS Form 3800, April 2015 PSN 7530-02-000-9047 See Reverse for Instructions

Postmark Here
W. Edgewood Ave
Teaneck
together

(Name)
 of Teaneck Health Dept.
 (Identify Dept./Agency Represented) (Badge No.)
 Residing at 818 Teaneck Rd Teaneck NJ 07661
 by certification or on oath, says that to the best of his/her knowledge or information and belief, the named defendant on or about the
03 10 2022 1PM

in TEANECK TOWNSHIP 0260 County of BERGEN NJ

did commit the following offense:
DEFENDANT failed to repair sidewalk.
(DESCRIPTION OF OFFENSE)
 in violation of (one charge only) 32-30
 (Statute, Regulation or Ordinance Number)

LOCATION OF OFFENSE **CODE** Describe Location
W. Edgewood Ave Teaneck NJ 07661
 OATH: Subscribed and sworn to before me this ___ day of ___, yr. ___
 CERTIFICATION: I certify that the fore-going statements made by me are true. I am aware that if any of the foregoing statements made by me are willfully false, I am subject to punishment.
 OR
 (Signature of Complaining Witness) 03/10/22 (Date)
 (Signature of Person Administering Oath) Walter Wong (Signature of Complaining Witness)

PROBABLE CAUSE DETERMINATION FOR ISSUANCE OF PROCESS:

| COURT USE ONLY | LAW / CODE ENFORCEMENT USE ONLY |
|---|--|
| Probable cause is found for the issuance of this Complaint-Summons <input type="checkbox"/> Yes <input checked="" type="checkbox"/> No (Signature of Judicial Officer) (Signature of Judge) | <input checked="" type="checkbox"/> The complaining witness is a law enforcement officer with territorial and subject matter jurisdiction and a judicial probable cause determination is not required prior to the issuance of this Complaint-Summons. |

YOU ARE HEREBY SUMMONED TO APPEAR
 BEFORE THIS COURT TO ANSWER THIS COMPLAINT. IF YOU FAIL TO APPEAR ON THE DATE AND AT THE TIME STATED, A WARRANT MAY BE ISSUED FOR YOUR ARREST.

NOTICE TO APPEAR

COURT APPEARANCE REQUIRED
 COURT DATE 4/13/22 9:30 (AM/PM)
 (Date Summons Issued) (Signature of Person Issuing Summons)

COMPLAINANT

SUMMONS

COURT I.D. PREFIX COMPLAINT NUMBER
0260 SC 010349

TEANECK TOWNSHIP
 MUNICIPAL COURT
 818 Teaneck Road
 Teaneck, NJ 07666

Complaint
The State of New Jersey
 (Please Print) VS.
 Defendant's Name: First Initial Last
MENACHEN STEIN
 Address 492-C Cedar Lane suite 519 Teaneck
 City State Zip Code Telephone:
NJ 07661
 Birth Date: Mo. Day Yr. Sex Eyes Height Restrictions
 DL # State Exp. Date

STATE OF NEW JERSEY
 COUNTY OF BERGEN } SS:
 Complaining Witness: Nelson Wong
 of Teaneck Health Dept.
 (Identify Dept./Agency Represented) (Badge No.)
 Residing at 818 Teaneck Rd Teaneck NJ 07661
 by certification or on oath, says that to the best of his/her knowledge or information and belief, the named defendant on or about the
03 10 2022 1PM

in TEANECK TOWNSHIP 0260 County of BERGEN NJ

did commit the following offense:
DEFENDANT failed to repair sidewalk.
(DESCRIPTION OF OFFENSE)
 in violation of (one charge only) 32-30
 (Statute, Regulation or Ordinance Number)

LOCATION OF OFFENSE **CODE** Describe Location
W. Edgewood Ave Teaneck NJ 07661
 OATH: Subscribed and sworn to before me this ___ day of ___, yr. ___
 CERTIFICATION: I certify that the fore-going statements made by me are true. I am aware that if any of the foregoing statements made by me are willfully false, I am subject to punishment.
 OR
 (Signature of Complaining Witness) 03/10/22 (Date)
 (Signature of Person Administering Oath) Walter Wong (Signature of Complaining Witness)

PROBABLE CAUSE DETERMINATION FOR ISSUANCE OF PROCESS:

| COURT USE ONLY | LAW / CODE ENFORCEMENT USE ONLY |
|---|--|
| Probable cause is found for the issuance of this Complaint-Summons <input type="checkbox"/> Yes <input checked="" type="checkbox"/> No (Signature of Judicial Officer) (Signature of Judge) | <input checked="" type="checkbox"/> The complaining witness is a law enforcement officer with territorial and subject matter jurisdiction and a judicial probable cause determination is not required prior to the issuance of this Complaint-Summons. |

YOU ARE HEREBY SUMMONED TO APPEAR
 BEFORE THIS COURT TO ANSWER THIS COMPLAINT. IF YOU FAIL TO APPEAR ON THE DATE AND AT THE TIME STATED, A WARRANT MAY BE ISSUED FOR YOUR ARREST.

NOTICE TO APPEAR

COURT APPEARANCE REQUIRED
 COURT DATE 4/13/22 9:30 (AM/PM)
 (Date Summons Issued) (Signature of Person Issuing Summons)

COMPLAINANT

SUMMONS

COMPLAINANT

SUMMONS

SF (402)

IP RT ad 166

For delivery information, visit our website at www.usps.com

OFFICIAL USE

Certified Mail Fee \$ 7/12/21

Extra Services & Fees (check box, add fee as appropriate)

Return Receipt (hardcopy) \$ _____

Return Receipt (electronic) \$ _____

Certified Mail Restricted Delivery \$ _____

Adult Signature Required \$ _____

Adult Signature Restricted Delivery \$ _____

Postage \$ _____

Total Postage and Fees \$ _____

Sent to Ms. W. Berglund 1 Ave

Street and Apt. No., or PO Box No.

City, State, ZIP+4® _____

PS Form 3800, April 2015 PSN 7530-02-000-9047 See Reverse for Instructions

COMPLAINT

COMPLAINT

(Name)
of Teamick Health Dept

(Identify Dept/Agency Representative) (Badge No.)
Residing at 818 Teaneck Rd Teaneck NJ 07666

by certification or on oath, says that to the best of his/her knowledge or information and belief, the named defendant on or about the 07/00/21 10am

Month Day Year Time

in TEANECK TOWNSHIP 0260 County of BERGEN NJ

did commit the following offense:
Failure to maintain plumbing facilities in good repair. 29A-53

(DESCRIPTION OF OFFENSE)

in violation of (one charge only) _____ (Statute, Regulation or Ordinance Number)

LOCATION OF OFFENSE **CODE** Describe Location
W. Inglewood Ave. Teaneck NJ

OATH: Subscribed and sworn to before me this _____ day of _____, yr. _____

(Signature of Complaining Witness) Julie Woy (Date) 7/1/00/21

(Signature of Person Administering Oath) _____ (Signature of Complaining Witness) _____

CERTIFICATION: I certify that the foregoing statements made by me are true. I am aware that if any of the foregoing statements made by me are willfully false, I am subject to punishment.

PROBABLE CAUSE DETERMINATION FOR ISSUANCE OF PROCESS:

| COURT USE ONLY | LAW / CODE ENFORCEMENT USE ONLY |
|--|--|
| Probable cause is found for the issuance of this Complaint-Summons <input type="checkbox"/> Yes <input checked="" type="checkbox"/> No (Signature of Judicial Officer) | <input checked="" type="checkbox"/> The complaining witness is a law enforcement officer or a code enforcement officer with territorial and subject matter jurisdiction and a judicial probable cause determination is not required prior to the issuance of this Complaint-Summons. |
| <input type="checkbox"/> Yes <input checked="" type="checkbox"/> No (Signature of Judge) | |

YOU ARE HEREBY SUMMONED TO APPEAR BEFORE THIS COURT TO ANSWER THIS COMPLAINT. IF YOU FAIL TO APPEAR ON THE DATE AND AT THE TIME STATED, A WARRANT MAY BE ISSUED FOR YOUR ARREST.

NOTICE TO APPEAR

COURT APPEARANCE REQUIRED

COURT DATE Month Day Year Time 8/4/21 9:30 AM

7/8/21 Julie Woy

(Date Summons Issued) (Signature of Person Issuing Summons)

SUMMONS

SUMMONS

9/00/21
FTA

COURT I.D. PREFIX COMPLAINT NUMBER

0260 - SC - 010288

TEANECK TOWNSHIP
MUNICIPAL COURT
818 Teaneck Road
Teaneck, NJ 07666

Complaint

The State of New Jersey

(Please Print) **VS.**

Defendant's Name: First Initial Last
26 West Englewood LLC

Address 492 Cedar Lane #519 Teaneck

City State Zip Code Telephone: _____

Birth Date: _____ Sex _____ Eyes _____ Height _____ Restrictions _____

DL # _____ State _____ Exp. Date _____

STATE OF NEW JERSEY
COUNTY OF BERGEN } SS:

Complaining Witness: Nelson Wong

(Name)
of Teamick Health Dept

(Identify Dept/Agency Representative) (Badge No.)
Residing at 818 Teaneck Rd Teaneck NJ 07666

by certification or on oath, says that to the best of his/her knowledge or information and belief, the named defendant on or about the 07/00/21 10am

Month Day Year Time

in TEANECK TOWNSHIP 0260 County of BERGEN NJ

did commit the following offense:
Failure to maintain plumbing facilities in good repair. 29A-53

(DESCRIPTION OF OFFENSE)

in violation of (one charge only) _____ (Statute, Regulation or Ordinance Number)

Failure to maintain plumbing facilities in good repair. 29A-53

LOCATION OF OFFENSE **CODE** Describe Location
W. Inglewood Ave. Teaneck NJ

OATH: Subscribed and sworn to before me this _____ day of _____, yr. _____

(Signature of Complaining Witness) Julie Woy (Date) 7/1/00/21

(Signature of Person Administering Oath) _____ (Signature of Complaining Witness) _____

CERTIFICATION: I certify that the foregoing statements made by me are true. I am aware that if any of the foregoing statements made by me are willfully false, I am subject to punishment.

PROBABLE CAUSE DETERMINATION FOR ISSUANCE OF PROCESS:

| COURT USE ONLY | LAW / CODE ENFORCEMENT USE ONLY |
|--|--|
| Probable cause is found for the issuance of this Complaint-Summons <input type="checkbox"/> Yes <input checked="" type="checkbox"/> No (Signature of Judicial Officer) | <input checked="" type="checkbox"/> The complaining witness is a law enforcement officer or a code enforcement officer with territorial and subject matter jurisdiction and a judicial probable cause determination is not required prior to the issuance of this Complaint-Summons. |
| <input type="checkbox"/> Yes <input checked="" type="checkbox"/> No (Signature of Judge) | |

YOU ARE HEREBY SUMMONED TO APPEAR BEFORE THIS COURT TO ANSWER THIS COMPLAINT. IF YOU FAIL TO APPEAR ON THE DATE AND AT THE TIME STATED, A WARRANT MAY BE ISSUED FOR YOUR ARREST.

NOTICE TO APPEAR

COURT APPEARANCE REQUIRED

COURT DATE Month Day Year Time 8/4/21 9:30 AM

7/8/21 Julie Woy

(Date Summons Issued) (Signature of Person Issuing Summons)

SUMMONS

SUMMONS

FIX COMPLAINT NUMBER
SC - **010289**

TEANECK TOWNSHIP
 MUNICIPAL COURT
 818 Teaneck Road
 Teaneck, NJ 07666

The State of New Jersey

(Please Print) VS.
 Defendant's Name: First Initial Last
26 West Englewood LLC
 Address City
492 Cedar Lane #519 Teaneck
 State Zip Code Telephone: _____
 Birth Date: Mo. Day Yr. Sex Eyes Height Restrictions
 DL # _____ State Exp. Date _____

STATE OF NEW JERSEY
 COUNTY OF BERGEN } SS:

Complaining Witness: NEKSON WONG
 of Teaneck Health Dept.
 Residing at 818 Teaneck Rd Teaneck NJ 07666
 by certification or on oath, says that to the best of his/her knowledge or information and belief, the named defendant on or about the
07/08/21 10AM
 in TEANECK TOWNSHIP 0260 County of BERGEN NJ

did commit the following offense:
failure to clean AND disinfect
(DESCRIPTION OF OFFENSE)
BASEMENT AFTER SEWER BACKUP 21-258A
 in violation of (one charge only)

| LOCATION OF OFFENSE | CODE | Describe Location |
|---------------------|------|------------------------------------|
| | | <u>W. Westwood Dr. Teaneck, NJ</u> |

OATH: Subscribed and sworn to before me this _____ day of _____, yr. _____

CERTIFICATION: I certify that the fore-going statements made by me are true. I am aware that if any of the foregoing statements made by me are willfully false, I am subject to punishment.

OR 07/08/21
 (Date)
John C Wong
 (Signature of Complaining Witness)

PROBABLE CAUSE DETERMINATION FOR ISSUANCE OF PROCESS:

| COURT USE ONLY | LAW / CODE ENFORCEMENT USE ONLY |
|---|--|
| Probable cause is found for the issuance of this Complaint-Summons <input type="checkbox"/> Yes <input checked="" type="checkbox"/> No (Signature of Judicial Officer) | <input checked="" type="checkbox"/> The complaining witness is a law enforcement officer or a code enforcement officer with territorial and subject matter jurisdiction and a judicial probable cause determination is not required prior to the issuance of this Complaint-Summons. |

YOU ARE HEREBY SUMMONED TO APPEAR
 BEFORE THIS COURT TO ANSWER THIS COMPLAINT. IF YOU FAIL TO APPEAR ON THE DATE AND AT THE TIME STATED, A WARRANT MAY BE ISSUED FOR YOUR ARREST.

NOTICE TO APPEAR

| COURT APPEARANCE REQUIRED | COURT DATE | Month | Day | Year | Time | AM-PM |
|---------------------------|---------------|----------|----------|-------------|--------------|-----------|
| <input type="checkbox"/> | <u>7/8/21</u> | <u>7</u> | <u>8</u> | <u>2021</u> | <u>10:00</u> | <u>AM</u> |

(Date-Summons Issued) _____ (Signature of Person Issuing Summons) _____

9/20/21
FTA

COURT I.D. PREFIX COMPLAINT NUMBER
0260 - **SC** - **010289**

TEANECK TOWNSHIP
 MUNICIPAL COURT
 818 Teaneck Road
 Teaneck, NJ 07666

The State of New Jersey
 (Please Print) VS.
 Defendant's Name: First Initial Last
26 West Englewood LLC
 Address City
492 Cedar Lane #519 Teaneck
 State Zip Code Telephone: _____
 Birth Date: Mo. Day Yr. Sex Eyes Height Restrictions
 DL # _____ State Exp. Date _____

STATE OF NEW JERSEY
 COUNTY OF BERGEN } SS:

Complaining Witness: NEKSON WONG
 of Teaneck Health Dept.
 Residing at 818 Teaneck Rd Teaneck NJ 07666
 by certification or on oath, says that to the best of his/her knowledge or information and belief, the named defendant on or about the
07/08/21 10AM
 in TEANECK TOWNSHIP 0260 County of BERGEN NJ

did commit the following offense:
failure to clean AND disinfect
(DESCRIPTION OF OFFENSE)
BASEMENT AFTER SEWER BACKUP 21-258A
 in violation of (one charge only)

| LOCATION OF OFFENSE | CODE | Describe Location |
|---------------------|------|------------------------------------|
| | | <u>W. Westwood Dr. Teaneck, NJ</u> |

OATH: Subscribed and sworn to before me this _____ day of _____, yr. _____

CERTIFICATION: I certify that the fore-going statements made by me are true. I am aware that if any of the foregoing statements made by me are willfully false, I am subject to punishment.

OR 07/08/21
 (Date)
John C Wong
 (Signature of Complaining Witness)

PROBABLE CAUSE DETERMINATION FOR ISSUANCE OF PROCESS:

| COURT USE ONLY | LAW / CODE ENFORCEMENT USE ONLY |
|---|--|
| Probable cause is found for the issuance of this Complaint-Summons <input type="checkbox"/> Yes <input checked="" type="checkbox"/> No (Signature of Judicial Officer) | <input checked="" type="checkbox"/> The complaining witness is a law enforcement officer or a code enforcement officer with territorial and subject matter jurisdiction and a judicial probable cause determination is not required prior to the issuance of this Complaint-Summons. |

YOU ARE HEREBY SUMMONED TO APPEAR
 BEFORE THIS COURT TO ANSWER THIS COMPLAINT. IF YOU FAIL TO APPEAR ON THE DATE AND AT THE TIME STATED, A WARRANT MAY BE ISSUED FOR YOUR ARREST.

NOTICE TO APPEAR

| COURT APPEARANCE REQUIRED | COURT DATE | Month | Day | Year | Time | AM-PM |
|---------------------------|---------------|----------|----------|-------------|--------------|-----------|
| <input type="checkbox"/> | <u>7/8/21</u> | <u>7</u> | <u>8</u> | <u>2021</u> | <u>10:00</u> | <u>AM</u> |

(Date-Summons Issued) _____ (Signature of Person Issuing Summons) _____

SUMMONS

SUMMONS

USPS CERTIFIED MAIL RECEIPT

HIP
IRT
oad
666

For delivery information, visit our website at www.usps.com

OFFICIAL USE

Certified Mail Fee \$
Extra Services & Fees (check box, add fee as appropriate)
Return Receipt (hardcopy) \$
Return Receipt (electronic) \$
Certified Mail Restricted Delivery \$
Adult Signature Required \$
Adult Signature Restricted Delivery \$
Postage \$
Total Postage and Fees \$
Sender: Menachem Stein
Street and Apt. No., or PO Box No. 492-C Cedar Lane
City, State, ZIP+4® Teaneck NJ 07666
PS Form 3800, April 2011 (PSN 7530-02-000-9047) See Reverse for Instructions

COMPLAINANT
of Teaneck Health Dept.
Residing at 818 Teaneck Rd Teaneck NJ 07666
by certification or on oath, says that to the best of his/her knowledge or information and belief, the named defendant on or about the 09/22/21 10am in TEANECK TOWNSHIP 0260 County of BERGEN NJ did commit the following offense:
(DESCRIPTION OF OFFENSE) Failure to obtain a Certificate of Health. 29A-9 d
in violation of (one charge only) (Statute, Regulation or Ordinance Number)

LOCATION OF OFFENSE CODE Describe Location
OATH: Subscribed and sworn to before me this ___ day of ___, yr. ___
CERTIFICATION: I certify that the foregoing statements made by me are true. I am aware that if any of the foregoing statements made by me are willfully false, I am subject to punishment.
(Signature of Complaining Witness) OR (Date) 09/22/21
(Signature of Person Administering Oath) (Signature of Complaining Witness)

PROBABLE CAUSE DETERMINATION FOR ISSUANCE OF PROCESS:
COURT USE ONLY LAW / CODE ENFORCEMENT USE ONLY
Probable cause is found for the issuance Of this Complaint-Summons
Yes No (Signature of Judicial Officer)
Yes No (Signature of Judge)
The complaining witness is a law enforcement officer or a code enforcement officer with territorial and subject matter jurisdiction and a judicial probable cause determination is not required prior to the issuance of this Complaint-Summons.

SUMMONS
YOU ARE HEREBY SUMMONED TO APPEAR BEFORE THIS COURT TO ANSWER THIS COMPLAINT. IF YOU FAIL TO APPEAR ON THE DATE AND AT THE TIME STATED, A WARRANT MAY BE ISSUED FOR YOUR ARREST.

NOTICE TO APPEAR
COURT APPEARANCE REQUIRED COURT DATE Month Day Year Time 9:30 AM PM
9/22/21 (Date Summons Issued) (Signature of Person Issuing Summons)

COURT I.D. PREFIX COMPLAINT NUMBER
0260 SC 010272
TEANECK TOWNSHIP MUNICIPAL COURT
818 Teaneck Road Teaneck, NJ 07666

Complaint
The State of New Jersey
(Please Print) VS.
Defendant's Name: First Initial Last
Menachem Stein
Address 492-C Cedar Lane Teaneck
State Zip Code Telephone: NJ 07666
Birth Date: Mo. Day Yr. Sex Eyes Height Restrictions
DL # State Exp. Date

COMPLAINANT
STATE OF NEW JERSEY COUNTY OF BERGEN } SS:
Complaining Witness: Nelson Wong
of Teaneck Health Dept.
Residing at 818 Teaneck Rd Teaneck NJ 07666
by certification or on oath, says that to the best of his/her knowledge or information and belief, the named defendant on or about the 09/22/21 10am in TEANECK TOWNSHIP 0260 County of BERGEN NJ did commit the following offense:

(DESCRIPTION OF OFFENSE) Failure to obtain a Certificate of Health. 29A-9 d
in violation of (one charge only) (Statute, Regulation or Ordinance Number)

LOCATION OF OFFENSE CODE Describe Location
OATH: Subscribed and sworn to before me this ___ day of ___, yr. ___
CERTIFICATION: I certify that the foregoing statements made by me are true. I am aware that if any of the foregoing statements made by me are willfully false, I am subject to punishment.
(Signature of Complaining Witness) OR (Date) 09/22/21
(Signature of Person Administering Oath) (Signature of Complaining Witness)

PROBABLE CAUSE DETERMINATION FOR ISSUANCE OF PROCESS:
COURT USE ONLY LAW / CODE ENFORCEMENT USE ONLY
Probable cause is found for the issuance Of this Complaint-Summons
Yes No (Signature of Judicial Officer)
Yes No (Signature of Judge)
The complaining witness is a law enforcement officer or a code enforcement officer with territorial and subject matter jurisdiction and a judicial probable cause determination is not required prior to the issuance of this Complaint-Summons.

SUMMONS
YOU ARE HEREBY SUMMONED TO APPEAR BEFORE THIS COURT TO ANSWER THIS COMPLAINT. IF YOU FAIL TO APPEAR ON THE DATE AND AT THE TIME STATED, A WARRANT MAY BE ISSUED FOR YOUR ARREST.

NOTICE TO APPEAR
COURT APPEARANCE REQUIRED COURT DATE Month Day Year Time 9:30 AM PM
9/22/21 (Date Summons Issued) (Signature of Person Issuing Summons)

COURT I.D. PREFIX COMPLAINT NUMBER
0260 SC 010271

TEANECK TOWNSHIP
 MUNICIPAL COURT
 818 Teaneck Road
 Teaneck, NJ 07666

Complaint

The State of New Jersey

(Please Print) **VS.**

Defendant's Name: First Initial Last
 MENACHEM STEIN

Address
 492-C Cedar Lane Teaneck

State Zip Code Telephone: 1

Birth Date: Mo. Day Yr. Sex Eyes Height Restrictions

DL # State Exp. Date

STATE OF NEW JERSEY } SS:
 COUNTY OF **BERGEN**

Complaining Witness: **Nelson Wong**
 of **Teaneck Health Dept.**
 Residing at **318 Teaneck Rd Teaneck NJ 07666**
 by certification or on oath, says that to the best of his/her knowledge or information and belief, the named defendant on or about the **09/22/21** at **10AM** in **TEANECK TOWNSHIP 0260** County of **BERGEN NJ** did commit the following offense:
Failure to maintain dwelling free from vermin, insect pest and rodent 21-28K
 (DESCRIPTION OF OFFENSE)
 in violation of (one charge only)

LOCATION OF OFFENSE **CODE** Describe Location **N. Lincolnwood Ave Teaneck NJ 07666**

OATH: Subscribed and sworn to before me this ___ day of ___, yr. **09/22/21**

(Signature of Complaining Witness) **Nelson Wong** (Date)

(Signature of Person Administering Oath) **Nelson Wong** (Signature of Complaining Witness)

PROBABLE CAUSE DETERMINATION FOR ISSUANCE OF PROCESS:

| COURT USE ONLY | LAW / CODE ENFORCEMENT USE ONLY |
|--|---|
| Probable cause is found for the issuance of this Complaint-Summons <input type="checkbox"/> Yes <input checked="" type="checkbox"/> No (Signature of Judicial Officer) | The complaining witness is a law enforcement officer or a code enforcement officer with territorial and subject matter jurisdiction and a judicial probable cause determination is not required prior to the issuance of this Complaint-Summons. <input checked="" type="checkbox"/> Yes <input type="checkbox"/> No (Signature of Judge) |

YOU ARE HEREBY SUMMONED TO APPEAR

BEFORE THIS COURT TO ANSWER THIS COMPLAINT. IF YOU FAIL TO APPEAR ON THE DATE AND AT THE TIME STATED, A WARRANT MAY BE ISSUED FOR YOUR ARREST.

NOTICE TO APPEAR

COURT APPEARANCE REQUIRED

COURT DATE **10/13/21** Time **9:30 AM**

(Date-Summons Issued) **9/22/21** (Signature of Person Issuing Summons) **Nelson Wong**

COURT I.D. PREFIX COMPLAINT NUMBER
0260 SC 010271

TEANECK TOWNSHIP
 MUNICIPAL COURT
 818 Teaneck Road
 Teaneck, NJ 07666

Complaint

The State of New Jersey

(Please Print) **VS.**

Defendant's Name: First Initial Last
 MENACHEM STEIN

Address
 492-C Cedar Lane Teaneck

State Zip Code Telephone: 1

Birth Date: Mo. Day Yr. Sex Eyes Height Restrictions

DL # State Exp. Date

STATE OF NEW JERSEY } SS:
 COUNTY OF **BERGEN**

Complaining Witness: **Nelson Wong**
 of **Teaneck Health Dept.**
 Residing at **318 Teaneck Rd Teaneck NJ 07666**
 by certification or on oath, says that to the best of his/her knowledge or information and belief, the named defendant on or about the **09/22/21** at **10AM** in **TEANECK TOWNSHIP 0260** County of **BERGEN NJ** did commit the following offense:
Failure to maintain dwelling free from vermin, insect pest and rodent 21-28K
 (DESCRIPTION OF OFFENSE)
 in violation of (one charge only)

LOCATION OF OFFENSE **CODE** Describe Location **N. Lincolnwood Ave Teaneck NJ 07666**

OATH: Subscribed and sworn to before me this ___ day of ___, yr. **09/22/21**

(Signature of Complaining Witness) **Nelson Wong** (Date)

(Signature of Person Administering Oath) **Nelson Wong** (Signature of Complaining Witness)

PROBABLE CAUSE DETERMINATION FOR ISSUANCE OF PROCESS:

| COURT USE ONLY | LAW / CODE ENFORCEMENT USE ONLY |
|--|---|
| Probable cause is found for the issuance of this Complaint-Summons <input type="checkbox"/> Yes <input checked="" type="checkbox"/> No (Signature of Judicial Officer) | The complaining witness is a law enforcement officer or a code enforcement officer with territorial and subject matter jurisdiction and a judicial probable cause determination is not required prior to the issuance of this Complaint-Summons. <input checked="" type="checkbox"/> Yes <input type="checkbox"/> No (Signature of Judge) |

YOU ARE HEREBY SUMMONED TO APPEAR

BEFORE THIS COURT TO ANSWER THIS COMPLAINT. IF YOU FAIL TO APPEAR ON THE DATE AND AT THE TIME STATED, A WARRANT MAY BE ISSUED FOR YOUR ARREST.

NOTICE TO APPEAR

COURT APPEARANCE REQUIRED

COURT DATE **10/13/21** Time **9:30 AM**

COMPLAINT

COMPLAINT

COMPLAINT

COMPLAINT

COURT I.D. PREFIX COMPLAINT NUMBER
0260 - SC - 010270

TEANECK TOWNSHIP
 MUNICIPAL COURT
 818 Teaneck Road
 Teaneck, NJ 07666

COURT I.D. PREFIX COMPLAINT NUMBER
0260 - SC - 010270

TEANECK TOWNSHIP
 MUNICIPAL COURT
 818 Teaneck Road
 Teaneck, NJ 07666

Complaint

The State of New Jersey

(Please Print) VS.

Defendant's Name: First Initial Last
 MENACHEN Initial STEIN Last

Address
 492-C Cedar Lane Teaneck

State Zip Code Telephone:
 NJ 07666

Birth Date: Mo. Day Yr. Sex Eyes Height Restrictions

DL #

STATE OF NEW JERSEY COUNTY OF BERGEN } SS:

The State of New Jersey

(Please Print) VS.

Defendant's Name: First Initial Last
 MENACHEN Initial STEIN Last

Address
 492-C Cedar Lane Teaneck

State Zip Code Telephone:
 NJ 07666

Birth Date: Mo. Day Yr. Sex Eyes Height Restrictions

DL #

STATE OF NEW JERSEY COUNTY OF BERGEN } SS:

Complaining Witness: Nelson Wong
 of Teaneck Health Dept.
 Residing at 818 Teaneck Rd Teaneck NJ 07666
 by certification or on oath, says that to the best of his/her knowledge or information and belief, the named defendant on or about the 09/22/21 10AM
 in TEANECK TOWNSHIP 0260 County of BERGEN NJ
 did commit the following offense:
 Failure to maintain the dwelling
 (DESCRIPTION OF OFFENSE)
 in violation of (one charge only)
 (Statute, Regulation or Ordinance Number)

Complaining Witness: Nelson Wong
 of Teaneck Health Dept.
 Residing at 818 Teaneck Rd Teaneck NJ 07666
 by certification or on oath, says that to the best of his/her knowledge or information and belief, the named defendant on or about the 09/22/21 10AM
 in TEANECK TOWNSHIP 0260 County of BERGEN NJ
 did commit the following offense:
 Failure to maintain the dwelling
 (DESCRIPTION OF OFFENSE)
 in violation of (one charge only)
 (Statute, Regulation or Ordinance Number)

LOCATION OF OFFENSE CODE Describe Location
 0260 W. ENG WOOD AVE TEANECK NJ 07666

OATH: Subscribed and sworn to before me this ___ day of ___, yr. _____

(Signature of Complaining Witness) OR (Date) 09/22/21 (Signature of Complaining Witness)

(Signature of Person Administering Oath) (Signature of Complaining Witness)

LOCATION OF OFFENSE CODE Describe Location
 0260 W. ENG WOOD AVE TEANECK NJ 07666

OATH: Subscribed and sworn to before me this ___ day of ___, yr. _____

(Signature of Complaining Witness) OR (Date) 09/22/21 (Signature of Complaining Witness)

(Signature of Person Administering Oath) (Signature of Complaining Witness)

PROBABLE CAUSE DETERMINATION FOR ISSUANCE OF PROCESS:

| COURT USE ONLY | LAW / CODE ENFORCEMENT USE ONLY |
|--|---|
| Probable cause is found for the issuance of this Complaint-Summons <input type="checkbox"/> Yes <input checked="" type="checkbox"/> No (Signature of Judicial Officer) | The complaining witness is a law enforcement officer or a code enforcement officer with territorial and subject matter jurisdiction and a judicial probable cause determination is not required prior to the issuance of this Complaint-Summons. <input checked="" type="checkbox"/> Yes <input type="checkbox"/> No (Signature of Judge) |

PROBABLE CAUSE DETERMINATION FOR ISSUANCE OF PROCESS:

| COURT USE ONLY | LAW / CODE ENFORCEMENT USE ONLY |
|--|---|
| Probable cause is found for the issuance of this Complaint-Summons <input type="checkbox"/> Yes <input checked="" type="checkbox"/> No (Signature of Judicial Officer) | The complaining witness is a law enforcement officer or a code enforcement officer with territorial and subject matter jurisdiction and a judicial probable cause determination is not required prior to the issuance of this Complaint-Summons. <input checked="" type="checkbox"/> Yes <input type="checkbox"/> No (Signature of Judge) |

YOU ARE HEREBY SUMMONED TO APPEAR

BEFORE THIS COURT TO ANSWER THIS COMPLAINT. IF YOU FAIL TO APPEAR ON THE DATE AND AT THE TIME STATED, A WARRANT MAY BE ISSUED FOR YOUR ARREST.

NOTICE TO APPEAR

COURT APPEARANCE REQUIRED COURT DATE 10/13/21 Time 9:30 AM PM

9/22/21 (Date Summons Issued) Nelson Wong (Signature of Person Issuing Summons)

YOU ARE HEREBY SUMMONED TO APPEAR

BEFORE THIS COURT TO ANSWER THIS COMPLAINT. IF YOU FAIL TO APPEAR ON THE DATE AND AT THE TIME STATED, A WARRANT MAY BE ISSUED FOR YOUR ARREST.

NOTICE TO APPEAR

COURT APPEARANCE REQUIRED COURT DATE 10/13/21 Time 9:30 AM PM

9/22/21 (Date Summons Issued) Nelson Wong (Signature of Person Issuing Summons)

COMPLAINT

COMPLAINT

COMPLAINT

SUMMONS

SUMMONS

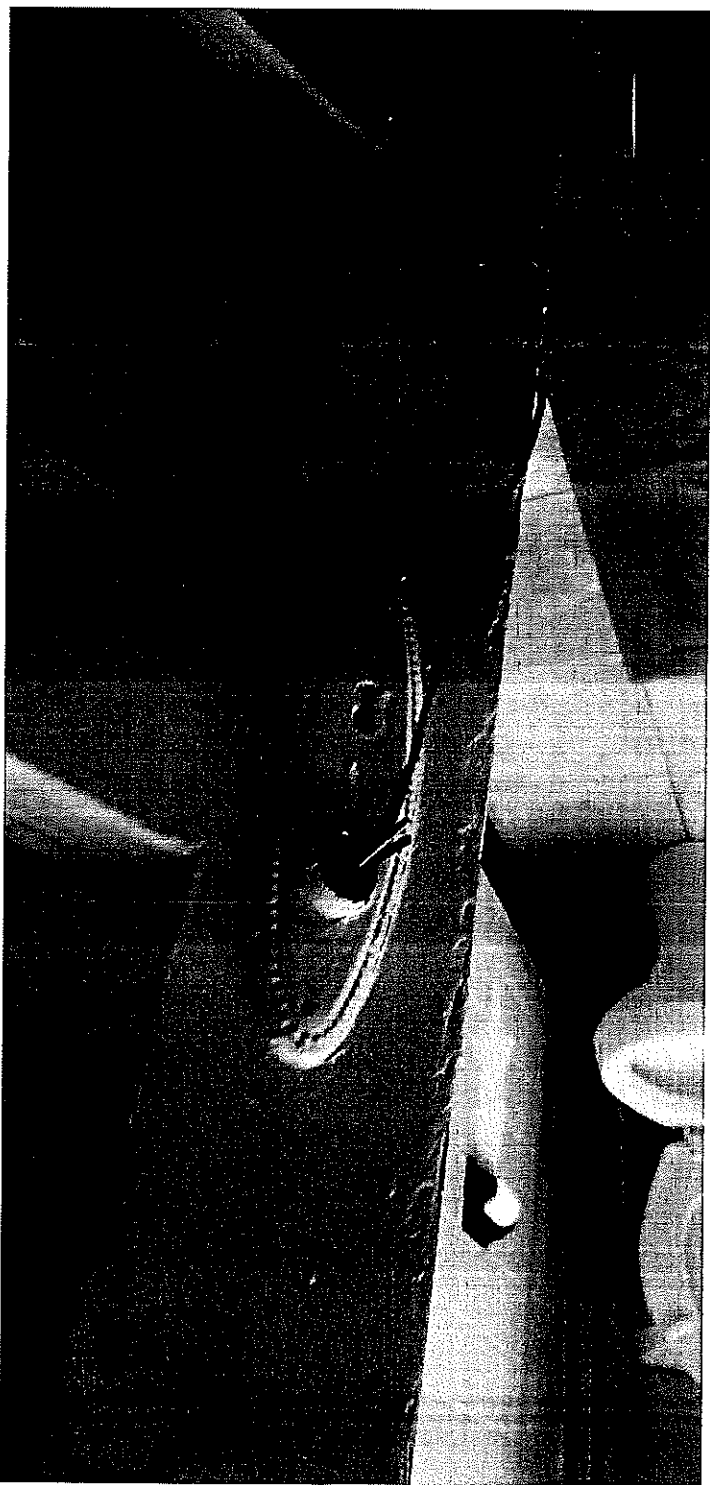

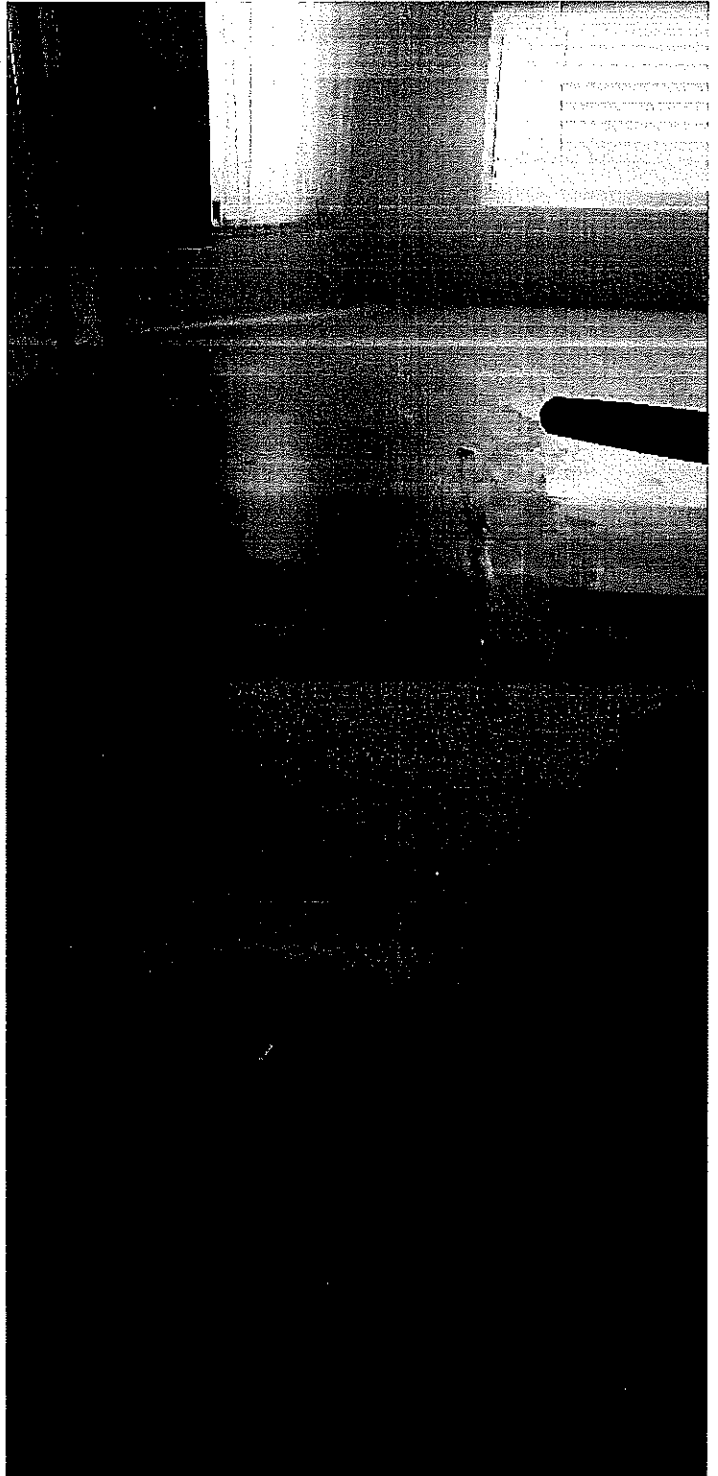

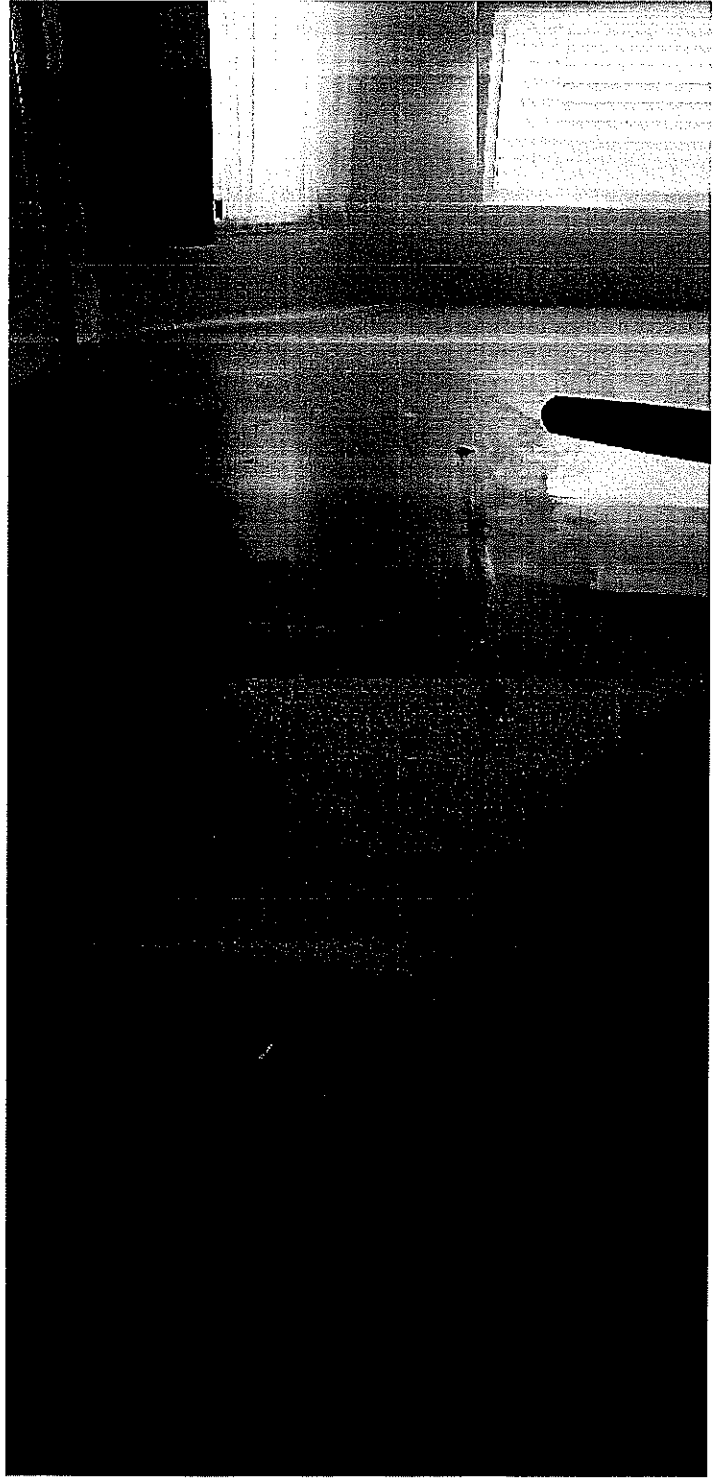

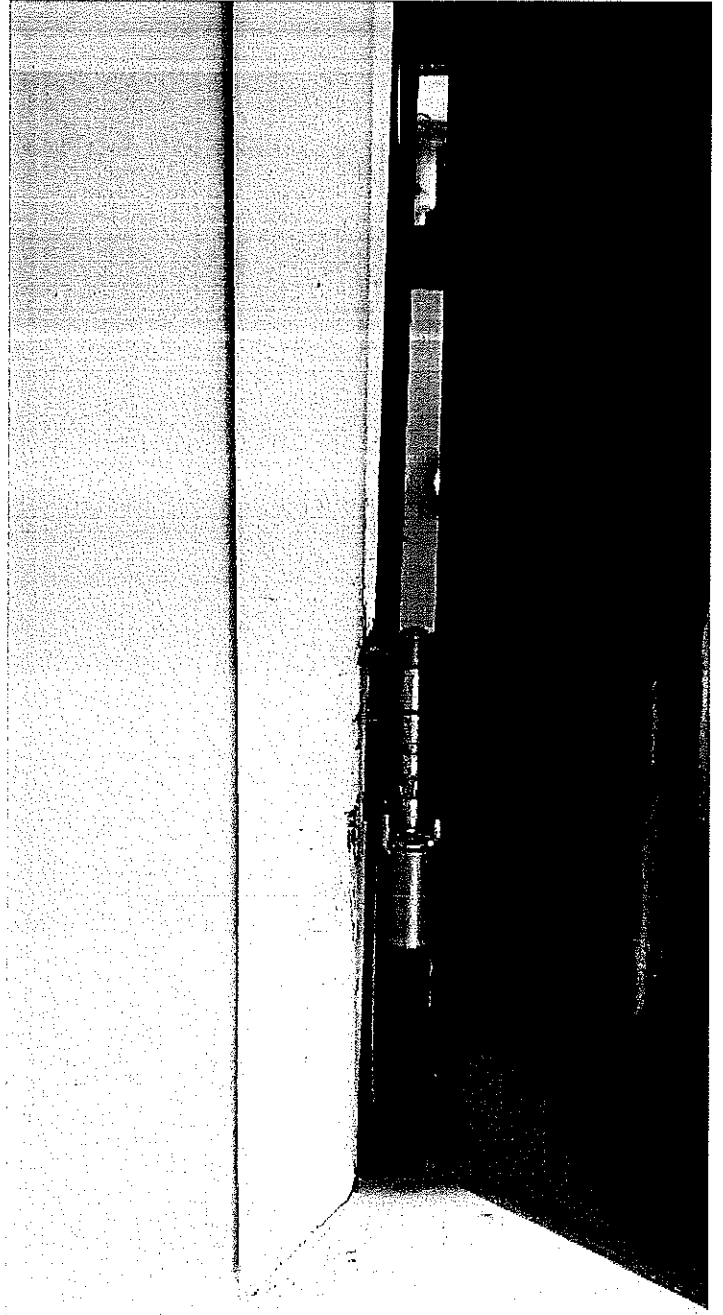

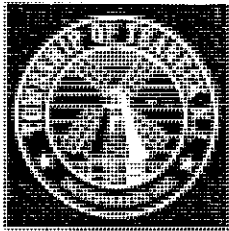

Township Of Teaneck

PAUL A. VOLCKER
MUNICIPAL GREEN
TEANECK, NEW JERSEY 07666
(201) 837-1600
E-MAIL: admin@teanecknj.gov
WEBSITE: www.teanecknj.gov

File FO 8/10/21

Mochi (also owner)
845-521-4571

July 15, 2021

26 West Englewood LLC
492-c Cedar Lane # 519
Teaneck, New Jersey 07666
cmngroupnj@gmail.com

Dear Landlord,

The Teaneck Health Department has received a few complaints about the conditions of your property at 26 West Englewood Avenue, Teaneck, New Jersey. A property maintenance inspection of the home conducted on July 09, 2021 revealed the following violations, as per sections 21 - 28 (a), 21- 28 (d), 21-28 (e), 21-28 (g), 21-28 (j) and 21-28 (k) of the township code.

- Repair wooden stairs leading to the basement. ✓
- Several doors and door knobs are missing or in disrepair.
- Peeling paint in the kitchen and Living room. Scrape and repaint.
- Licensed exterminator needed for rodent infestation. Proof of service required. ✓
- Seal off any opening and holes in the house to avoid entry of rodents (behind floor radiators, baseboards, etc.).
- Fix ceiling lights in the bedrooms, Living room and first floor bathroom.
- Main entrance door in disrepair. Replace or fix properly.

Failure to comply with the Township of Teaneck may result in the issuance of summonses. Please have all of these violations abated **within 14 days or before August 02, 2021.**

If you have any questions, please call me at the Teaneck Health Department, 201-837-1600 ext. 1508 or by e-mail at nwong@teanecknj.gov. Thank you very much, in advance, for your cooperation in this matter.

Yours truly,

Nelson O. Wong
Environmental Health Specialist
Teaneck Health Department



Printed on Recycled Stock



26 West Englewood Avenue (COH Inspection)

From: Nelson Wong <nwong@teanecknj.gov>
To: cmngroupnj@gmail.com
Cc: Nelson Wong <nwong@teanecknj.gov>
Date: 7/15/2021 4:20 PM

Mr. Moche,

As part of the process to obtain a COH (Certificate of Health) for the above property, a visual inspection of the home was needed. Please read the attached inspection report and let me know if you have any question. In order to pass the inspection you must abate all the violations before August 02, 2021.

Thank you.

Ps. I also mailed the report.

Nelson O. Wong
Registered Environmental Health Specialist
Teaneck Health Department
201-837-1600 Ext 1508

This email and any files transmitted with it are privileged and confidential and may be considered advisory, consultative and deliberative material under OPRA. This communication is intended solely for the use of the individual or entity to whom they are addressed. If you have received this email in error, please notify the system manager. This message contains confidential information and is intended only for the individual named. If you are not the named addressee you should not disseminate, distribute or copy this email. Please notify the sender immediately by email if you have received this email by mistake, please delete this email from your system. If you are not the intended recipient you are notified that disclosing, copying, distributing or taking any action in reliance on the contents of this information is strictly prohibited.

From: Nelson Wong <nwong@teanecknj.gov>
To: <cmngroupnj@gmail.com>
Cc: Curtis Caviness <ccaviness@teanecknj.gov>, Fausto Garcia Jr. <fgarcia@teanecknj.gov>
Sent: 7/12/2021 9:26 AM
Subject: Fwd: 26 West Englewood Avenue

Mr. Moche,

These are the first two summonses dated 7/8/21. I was off on Friday, so no summonses were issued. Please fix the sewer problem immediately and clean and sanitize the basement afterwards. Please remember that I notified you of these issues almost 11 days ago. I will continue to write court summonses on a daily basis until this problem is abated.

Thank you.

Nelson O. Wong
Registered Environmental Health Specialist
Teaneck Health Department
201-837-1600 Ext 1508

This email and any files transmitted with it are privileged and confidential and may be considered advisory, consultative and deliberative material under OPRA. This communication is intended solely for the use of the individual or entity to whom they are addressed. If you have received this email in error, please notify the system manager. This message contains confidential information and is intended only for the individual named. If you are not the named addressee you should not disseminate, distribute or copy this email. Please notify the sender immediately by email if you have received this email by mistake, please delete this email from your system. If you are not the intended recipient you are notified that disclosing, copying, distributing or taking any action in reliance on the contents of this information is strictly prohibited.

From: Nelson Wong <nwong@teanecknj.gov>
To: <cmngroupnj@gmail.com>
Cc: Nelson Wong <nwong@teanecknj.gov>, Curtis Caviness <ccaviness@teanecknj.gov>
Sent: 6/29/2021 4:39 PM
Subject: 26 West Englewood Avenue

Mr. Moshe,

As per our conversation today, I am sending you the following:

- Landlord Registration form
- Certificate of health form
- Section 29A-53 and Section 21-28 (d) of the township code. I also added some additional codes that landlords are responsible to maintain.

Please return both forms with the appropriate fees and arrange for an inspection of the house. Additionally, let me know as soon as the basement is cleaned and sanitized due to the sewage backup (assuming the problem was solved by a professional). Re-inspection of this property will be done on July 06 or later.

Let me know if you have any questions.

Sincerely,

Nelson O. Wong
Registered Environmental Health Specialist
Teaneck Health Department
201-837-1600 Ext 1508

This email and any files transmitted with it are privileged and confidential and may be considered advisory, consultative and deliberative material under OPRA. This communication is intended solely for the use of the individual or entity to whom they are addressed. If you have received this email in error, please notify the system manager. This message contains confidential information and is intended only for the individual named. If you are not the named addressee you should not disseminate, distribute or copy this email. Please notify the sender immediately by email if you have received this email by mistake, please delete this email from your system. If you are not the intended recipient you are notified that disclosing, copying, distributing or taking any action in reliance on the contents of this information is strictly prohibited.

This email and any files transmitted with it are privileged and confidential and may be considered advisory, consultative and deliberative material under OPRA. This communication is intended solely

for the use of the individual or entity to whom they are addressed. If you have received this email in error please notify the system manager. This message contains confidential information and is intended only for the individual named. If you are not the named addressee you should not disseminate, distribute or copy this email. Please notify the sender immediately by email if you have received this email by mistake and delete this email from your system. If you are not the intended recipient you are notified that disclosing, copying, distributing or taking any action in reliance on the contents of this information is strictly prohibited.

Attachments:

- 26 West Englewood Ave. COH Inspection Report.pdf

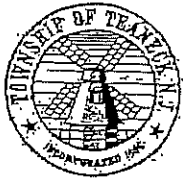

TEANECK HEALTH DEPARTMENT

818 TEANECK ROAD
TEANECK, NEW JERSEY 07666
(201) 837-1600

NW

SERVICE REQUEST

DATE: 6/29/21 TIME: 3:45 PM

RCV'D BY: NW

HOME #:

COMPLAINANT'S NAME: Silvia Tonia

ADDRESS: 26 W. Englewood Ave

WORK #: 201-598-2022 (c)

COMPLAINT: 26 West Englewood Ave

Sewage back up in the basement

Moshe 917-334-2188 (owner)
New Owner

Entered in log (CHECK) _____

FINDINGS:

6/29/21

see attached.

Valid complaint, as per New Owner.

Noted 7/14/21 NW

ACTION TAKEN:

E-mailed with attachments, will follow up after 7/6/21.

SIGNED NW

CAN Group NJ @gmp@1.com

26 West Englewood Avenue

From: Nelson Wong <nwong@teanecknj.gov>
To: cmngroupnj@gmail.com
Cc: Nelson Wong <nwong@teanecknj.gov>, Curtis Caviness <ccaviness@teanecknj.gov>
Date: 6/29/2021 4:39 PM

Mr. Moshe,

As per our conversation today, I am sending you the following:

- Landlord Registration form
- Certificate of health form
- Section 29A-53 and Section 21-28 (d) of the township code. I also added some additional codes that landlords are responsible to maintain.

Please return both forms with the appropriate fees and arrange for an inspection of the house. Additionally, let me know as soon as the basement is cleaned and sanitized due to the sewage backup (assuming the problem was solved by a professional). Re-inspection of this property will be done on July 06 or later.

Let me know if you have any questions.

Sincerely,

Nelson O. Wong
Registered Environmental Health Specialist
Teaneck Health Department
201-837-1600 Ext 1508

This email and any files transmitted with it are privileged and confidential and may be considered advisory, consultative and deliberative material under OPRA. This communication is intended solely for the use of the individual or entity to whom they are addressed. If you have received this email in error, please notify the system manager. This message contains confidential information and is intended only for the individual named. If you are not the named addressee you should not disseminate, distribute or copy this email. Please notify the sender immediately by email if you have received this email by mistake, please delete this email from your system. If you are not the intended recipient you are notified that disclosing, copying, distributing or taking any action in reliance on the contents of this information is strictly prohibited.

This email and any files transmitted with it are privileged and confidential and may be considered advisory, consultative and deliberative material under OPRA. This communication is intended solely for the use of the individual or entity to whom they are addressed. If you have received this email in error please notify the system manager. This message contains confidential information and is intended only for the individual named. If you are not the named addressee you should not disseminate, distribute or copy this email. Please notify the sender immediately by email if you have received this email by mistake and delete this email from your system. If you are not the intended recipient you are notified that disclosing, copying, distributing or taking any action in reliance on the contents of this information is strictly prohibited.

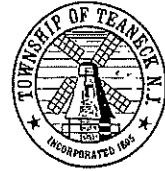

TEANECK HEALTH DEPARTMENT
818 TEANECK ROAD
TEANECK, NJ 07666
(201) 837-1600 Ext. 1500

CERTIFICATE OF HEALTH
APPLICATION (2021)

All rented one (1) family dwelling, lodging houses and superintendent's basement permits expire December 31st and are renewable during January 2021 (if rented). *(penalty after this date)

| | | |
|---------------------------------|-------|----------|
| Rented Single Family House | \$175 | <u>X</u> |
| Owner Occupied w/Rented Rooms** | \$90 | _____ |
| Superintendent's Apartment | \$120 | _____ |

Kindly check one of the choices and forward the appropriate fee payable to the Township of Teaneck and mail with the completed application below.

Address of Rented Premises: _____

Name of Owner: _____

Owner's Home Address: _____
(P.O. BOX IS NOT ACCEPTABLE)

Tele. # (Day): _____ (Night): _____

E-Mail: _____ Fax: _____

Name/Address Managing Agent: _____

Tele. # (Day): _____ (Night): _____

Occupant's Name: _____ Occupant's Tele. #: _____

** Teaneck Zoning Code prohibits renting to more than (2) lodgers in a single family dwelling

TOWNSHIP USE ONLY

Certificate # : _____ Date of Issue: _____

Reminder – contact Fire Prevention Bureau at 201-808-8080 ext. 5206 to obtain a Smoke Detector Certificate



TOWNSHIP OF TEANECK
Landlord Registration Form

Dear Owner/Operator

Address of Rented Premise: _____

In accordance with N.J.S.A. 46:8-27 et. Seq., please provide the Health Department with the following information:

A. The name, address, and phone #'s of the record owner(s); and the record owner(s) of the rental business, if not the same persons. In the case of a partnership, list the name(s) of all the general partners:

Telephone #: (Day) _____ Telephone #: (Evening) _____

B. If the record owner is a corporation, the name, address, and phone #'s of the registered agent/corporate officer are:

Telephone #: (Day) _____ Telephone #: (Evening) _____

C. A Bergen County agent is required for those property owner's who do not reside in the County. List the name(s), address, and phone #'s for the Bergen County agent, who is authorized to accept notices on behalf of the owner:

Telephone #: (Day) _____ Telephone #: (Evening) _____

D. The name, address, and phone #'s of the managing agent, if any:

Telephone #: (Day) _____ Telephone #: (Evening) _____

E. The name, address, and phone #'s of the superintendent, or persons employed for regular maintenance of the premises:

Telephone #: (Day) _____ Telephone #: (Evening) _____

F. No. Units on the premises: _____

G. Type of Heating used: _____

H. If oil heat is used and provided by owner, please list the name, address, and phone # for the oil company provider:

Address: _____ Telephone #: _____

I. The name, address, and phone #'s of those individuals who have the authority to make decisions concerning repairs or expenditures, in case of emergency: (if other than owner)

Date Received: _____

* Sec. 29A-53 Same — Maintenance of plumbing facilities.

[Ord.-No. 1329, § 5.]

Each facility required above shall be maintained in a sanitary condition, free from defects and in operating condition at all times. Where the facility or plumbing fixtures shall be clogged, overflow or otherwise necessitate repairs, such repairs shall be performed forthwith.

* Sec. 21-28 Responsibility of owner for general maintenance of dwelling.

It shall be the duty of and the responsibility of the owner of any dwelling:

(a)

To keep every dwelling and every part thereof, including the roof, walls, floors, provided refrigerators and stoves, provided carpeting, ceilings, attics, cellars, halls, stairs, stairways, porches, plumbing, provided heating plants and provided fixtures and equipment for heating water, including chimneys and smoke pipes, doors, windows, foundations and rubbish containers, in a state of sound repair and in a clean, sanitary condition.

(b)

To maintain such dwelling so there will not be excessive heat loss caused by lack of or improper maintenance of the doors, windows, walls, roofs or other parts of the building.

(c)

To refrain from shutting off or causing to have discontinued or disconnected provided utilities for any occupied dwelling, except where such interruption of utility service is necessary while in the actual process of making repairs or during temporary emergencies for which repairs are being arranged. If heat or other utility service must be interrupted for any reason under circumstances other than unanticipated breakdowns as provided for in Section 21-32, the custodian of the building shall notify all tenants who may be affected, at least 24 hours in advance, that the heat or utility service will be interrupted and the anticipated length of time of the interruption.

(d)

To keep the basement or cellar dry and ventilated. The floors of such basement or cellar shall be paved with brick, cement, tile or asphalt or with some other approved impervious material. The basement or cellar shall be kept clean and free from any accumulation of filth, ashes, garbage, rubbish, refuse, junk, soil matter, wood, paper and other combustible or putrefactive nature, and if not and request therefor is made by the health officer or his agent, the same shall be cleaned and disinfected. The use of any cellar for sleeping purposes is prohibited, except when used by a member of the family or by a domestic employed by the owner-occupant, if such room complies with the following conditions and when other rooms are not occupied by lodgers, boarders or other persons who are not members of the immediate family:

(1)

The room shall have a minimum of 490 cubic feet of air space.

(2)

The room shall have a minimum area of 70 square feet.

(3)

The room shall be free from dampness.

(4)

The room shall have a minimum height from floor to ceiling of seven feet.

(5)

The room shall have, in addition to existing stairs, a safe and unobstructed means of egress which shall lead to a safe and open space outside of the building.

(6)

Means of ventilating shall be provided by an easily operable window having an operable area of at least 45% of the minimum window area. The minimum window area shall be eight square feet and shall open readily directly to the street or yard.

(e)

Side walls and ceilings of such dwelling, dwelling unit and every habitable room, hall, closet and compartment shall be kept clean and well and sufficiently plastered, painted or papered, so that the same may have clean, smooth and washable surfaces.

(f)

The flooring of the halls, stairs and landings shall be kept clean and free from filth, ashes, garbage, rubbish, refuse, junk, soil water, drainage water, slop, wood, paper and other material of a putrefactive or combustible nature and free from fire and accident hazards.

(g)

The porches, stairways, landings, steps, floors, fire escapes, courts, yards, alleys, areaways, passageways and all surrounding exterior surfaces of any dwelling shall be kept free from any accumulations of filth, ashes, garbage, refuse, junk, paper, wood, soil matter, waste matter, drainage and other material of a combustible or putrefactive nature. Such places shall at all times be kept free from fire and accident hazards.

(h)

In every dwelling occupied by more than three families, in which the owner does not reside, a janitor, caretaker, housekeeper or other person designated by the owner shall be provided, who shall at all times keep the court, yard, alley, areaway, sidewalk and other exterior surfaces clean and free from any accumulations of waste material. Garbage and all waste material shall be moved from such dwelling premises at regular intervals and at the convenience and collection schedule of the garbage removal agency of the Township.

(i)

Chimneys, smokestacks, smokepipes, flues and provided heating equipment of such dwelling shall be maintained and kept free from defect and in such condition as to prevent coal or illuminating gas, soot, smoke or noxious fumes or odors from entering such dwelling, dwelling unit or habitable rooms or any dwelling or dwelling unit adjacent thereto.

(j)

The roof, gutters, leaders, side walls, windows and window frames of such dwelling and every part thereof shall be kept structurally sound and free from leakage and rain weather.

(k)

The dwelling shall be maintained free from vermin, insect pests and rodents.

(l)

In the absence of natural ventilation, every habitable room shall be ventilated by mechanical means.

(m)

In every tenancy where the owner has furnished or has agreed to furnish window screens and screen doors, or either, as a preventative against fly and mosquito infestation, such screening shall be at all times kept in good and serviceable condition.

(n)

In all dwellings constructed after the effective date of the Code of the Township of Teaneck, New Jersey, 1964, the occupant of every dwelling shall be provided with adequate window and door screens to maintain the same at all times in good and serviceable condition.

ELEVIN REAL ESTATE, LLC
172 WEST ENGLEWOOD AVE
TEANECK, NJ 07666

FU
4/30/2021

Extension
Request
Granted by
Engineer.

until
4/21/21
NW

November 18, 2020

Teaneck Municipal Building
Engineering Department
818 Teaneck Road
Teaneck, NJ 07666

Re: 20, 22, 26, & 47 West Englewood Ave
Teaneck, NJ 07666

To: Engineering Department

We have recently received a request to repair the sidewalks at the following properties:
20, 22, 26 and 47 West Englewood Avenue. The request had a deadline of December 1, 2020.

Due to the cold weather we are experiencing at the present time, we are requesting an extension to complete this work in an effective manner. Please contact Tom at 201-446-1286 if you have any questions. Thank you so much for your consideration.

Sincerely,

The Management

Cc. Nelson Wong
Teaneck Health Department

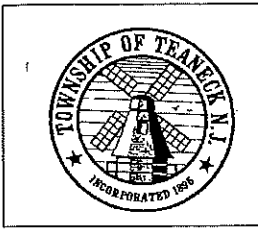

TEANECK HEALTH DEPARTMENT

818 TEANECK ROAD
TEANECK, NEW JERSEY 07666
(201) 837-1600 ext. 1500

NOTICE OF VIOLATION

Sent Certified and Regular Mail

Date:

10/ 13 / 20

Re: 20, 22, 26 West Englewod, Teaneck, NJ 07666
Name: Elie Katz (ETALS)
Mailing Address: 172 West Englewood Avenue, Teaneck, NJ 07666

YOU ARE HEREBY NOTIFIED TO HAVE THE FOLLOWING CONDITION(S) REMEDIED WITHIN (10) DAYS.

| <u>Section(s):</u> | <u>Violation(s):</u> |
|--------------------|--|
| 19 – 15 xx | - Remove junk and debris from the entire property. |
| 19 - 16** xx | - Remove overgrowth, weeds, junk, debris or other matter from the entire property. |
| 29A – 15 xx | - Maintain landscaping, bushes, hedges, etc. |

PLEASE TRIM BUSHES/HEDGES, REMOVE LITTER, DEBRIS, DEAD LEAVES, ETC. FROM ALL 3 PROPERTIES.

Re-inspection date on or after: 10 / 26 / 20

****FAILURE TO COMPLY MAY RESULT IN ENFORCEMENT ACTIONS BY THE TOWNSHIP INCLUDING THE ISSUANCE OF SUMMONS(ES) WITH A PENALTY OF UP TO \$500.00 PER CITATION AND/OR ABATEMENT OF THE VIOLATION(S) BY THE TOWNSHIP AT THE EXPENSE OF THE PROPERTY OWNER AND/OR RESPONSIBLE PARTY. THE COST OF THE ABATEMENT MAY GO UP TO \$2,500. THESE COST WILL BE APPLIED TO LABOR, OVER-TIME, EQUIPMENT, DUMPING/REMOVAL COSTS AND/OR LEGAL COSTS. THIS ACTION IS NECESSARY AS A PUBLIC HEALTH MEASURE (201) 837-1600 Ext. 1508 OR NWONG@TEANECKNJ.GOV. IF YOU DESIRE A HEARING, YOU MUST CONTACT THE TEANECK HEALTH DEPT. PRIOR TO THE REMEDIED TIME NOTED ABOVE.**

**Nelson O. Wong
Environmental Health Specialist
Teaneck Health Department**

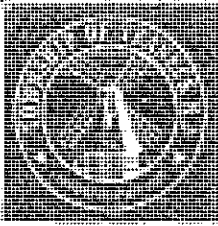

TEANECK HEALTH DEPARTMENT

818 TEANECK ROAD
TEANECK, NEW JERSEY 07666
201-837-1600 ext. 1500
Website: teanecknj.gov

10/2/20
NW

SERVICE REQUEST

DATE: 9.29.20 TIME: 10:30AM

RECV'D BY: JJ

COMPLAINANT: Diana Davis HOME#: 201-870-7508

ADDRESS: 47 West Englewood Avenue - 1st Floor WORK#: _____

CELL#: _____

COMPLAINT:

22, 24, and 26 West Englewood Avenue properties are all lacking the responsibility and upkeep of the lawn, trees, sidewalks, and front of property.

22, 24, 26 Sidewalks IN disrepair.

Entered in log (check)

FINDINGS:

- Sidewalk repairs will be referred to Engineering Dept.
- H.D. will take care of exterior property maintenance.

ACTION TAKEN:

D. sent copy to Engineering Dept for sidewalks.

SIGNED NW

TEANECK, NEW JERSEY

INFORMATION REQUEST - PROBLEM REPORT FORM

| TO: DEPARTMENT/OFFICE | | FROM: DEPARTMENT/OFFICE | |
|---|---------------------------------------|--------------------------------------|--|
| <input type="checkbox"/> Assessor | <input type="checkbox"/> Fire | <input type="checkbox"/> Assessor | <input type="checkbox"/> Fire |
| <input type="checkbox"/> Building | <input type="checkbox"/> Health | <input type="checkbox"/> Building | <input checked="" type="checkbox"/> Health |
| <input type="checkbox"/> Clerk | <input type="checkbox"/> Manager | <input type="checkbox"/> Clerk | <input type="checkbox"/> Manager |
| <input type="checkbox"/> Court | <input type="checkbox"/> Police | <input type="checkbox"/> Council | <input type="checkbox"/> Police |
| <input checked="" type="checkbox"/> Engineering | <input type="checkbox"/> Public Works | <input type="checkbox"/> Court | <input type="checkbox"/> Public Works |
| <input type="checkbox"/> Finance | <input type="checkbox"/> Recreation | <input type="checkbox"/> Engineering | <input type="checkbox"/> Recreation |
| | | <input type="checkbox"/> Finance | <input type="checkbox"/> Resident |
| | | | <input type="checkbox"/> Purchasing |

Reported/Requested By (include tel #) Ms. DAVIS 201-870-7508

Taken By: Nelson Wong x1505 Date: 10/2/20
Date: 10/2/20

I. INFORMATION REQUESTED:

II. PROBLEM REPORTED:

Location: 22, 24, 26 West Englewood Ave.

Nature of Problem: sidewalk in disrepair as per Ms. Davis complaint (see attach)

III. ACTION(S) TAKEN:

Signed: _____ Date: _____

White and Yellow Copies - Forward to appropriate department
(Yellow to be returned to originator after action)
Pink Copy - Retain for file

**ELEVIN REAL ESTATE, LLC
172 WEST ENGLEWOOD AVE
TEANECK, NJ 07666**

FU
4/30/2021

Extension
Request
Granted by
Engineer.

November 18, 2020

Teaneck Municipal Building
Engineering Department
818 Teaneck Road
Teaneck, NJ 07666

until
4/21/21
NW

Re: 20, 22, 26, & 47 West Englewood Ave
Teaneck, NJ 07666

To: Engineering Department

We have recently received a request to repair the sidewalks at the following properties:
20, 22, 26 and 47 West Englewood Avenue. The request had a deadline of December 1, 2020.

Due to the cold weather we are experiencing at the present time, we are requesting an extension to complete this work in an effective manner. Please contact Tom at 201-446-1286 if you have any questions. Thank you so much for your consideration.

Sincerely,
The Management

Cc. Nelson Wong
Teaneck Health Department

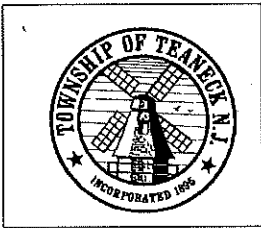

TEANECK HEALTH DEPARTMENT

818 TEANECK ROAD
TEANECK, NEW JERSEY 07666
(201) 837-1600 ext. 1500

NOTICE OF VIOLATION

Sent Certified and Regular Mail

Date:

10/ 13 / 20

Re: **20, 22, 26 West Englewod, Teaneck, NJ 07666**
Name: **Elie Katz (ETALS)**
Mailing Address: **172 West Englewood Avenue, Teaneck, NJ 07666**

YOU ARE HEREBY NOTIFIED TO HAVE THE FOLLOWING CONDITION(S) REMEDIED WITHIN (10) DAYS.

Section(s):

Violation(s):

- 19 - 15 xx - Remove junk and debris from the entire property.
- 19 - 16** xx - **Remove** overgrowth, weeds, junk, debris or **other matter from the entire property.**
- 29A - 15 xx - Maintain landscaping, bushes, hedges, etc.

PLEASE TRIM BUSHES/HEDGES, REMOVE LITTER, DEBRIS, DEAD LEAVES, ETC. FROM ALL 3 PROPERTIES.

Re-inspection date on or after: 10 / 26 / 20

****FAILURE TO COMPLY MAY RESULT IN ENFORCEMENT ACTIONS BY THE TOWNSHIP INCLUDING THE ISSUANCE OF SUMMONS(ES) WITH A PENALTY OF UP TO \$500.00 PER CITATION AND/OR ABATEMENT OF THE VIOLATION(S) BY THE TOWNSHIP AT THE EXPENSE OF THE PROPERTY OWNER AND/OR RESPONSIBLE PARTY. THE COST OF THE ABATEMENT MAY GO UP TO \$2,500. THESE COST WILL BE APPLIED TO LABOR, OVER-TIME, EQUIPMENT, DUMPING/REMOVAL COSTS AND/OR LEGAL COSTS. THIS ACTION IS NECESSARY AS A PUBLIC HEALTH MEASURE (201) 837-1600 Ext. 1508 OR NWONG@TEANECKNJ.GOV. IF YOU DESIRE A HEARING, YOU MUST CONTACT THE TEANECK HEALTH DEPT. PRIOR TO THE REMEDIED TIME NOTED ABOVE.**

**Nelson O. Wong
Environmental Health Specialist
Teaneck Health Department**

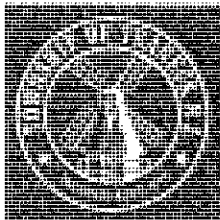

TEANECK HEALTH DEPARTMENT

818 TEANECK ROAD
TEANECK, NEW JERSEY 07666
201-837-1600 ext. 1500
Website: teanecknj.gov

10/29/20
NW

SERVICE REQUEST

DATE: 9.29.20 TIME: 10:30AM

RECV'D BY: JJ

COMPLAINANT: Diana Davis HOME#: 201-870-7508

ADDRESS: 47 West Englewood Avenue - 1st Floor WORK#: _____

CELL#: _____

COMPLAINT:

22, 24, and 26 West Englewood Avenue properties are all lacking the responsibility and upkeep of the lawn, trees, sidewalks, and front of property.

22, 24, 26 Sidewalks IN disrepair.

Entered in log (check)

FINDINGS:

- Sidewalk repairs will be referred to
- Engineering Dept.
- A.D. will take care of exterior property maintenance

ACTION TAKEN:

1. sent copy to Engineering Dept for sidewalks.

SIGNED NW

TEANECK, NEW JERSEY
INFORMATION REQUEST - PROBLEM REPORT FORM

| TO: DEPARTMENT/OFFICE | FROM: DEPARTMENT/OFFICE |
|---|--|
| <input type="checkbox"/> Assessor | <input type="checkbox"/> Assessor |
| <input type="checkbox"/> Building | <input checked="" type="checkbox"/> Fire |
| <input type="checkbox"/> Clerk | <input checked="" type="checkbox"/> Health |
| <input type="checkbox"/> Court | <input type="checkbox"/> Manager |
| <input checked="" type="checkbox"/> Engineering | <input type="checkbox"/> Police |
| <input type="checkbox"/> Finance | <input type="checkbox"/> Public Works |
| <input type="checkbox"/> Fire | <input type="checkbox"/> Recreation |
| <input type="checkbox"/> Health | <input type="checkbox"/> Resident |
| <input type="checkbox"/> Manager | <input type="checkbox"/> Purchasing |
| <input type="checkbox"/> Police | |
| <input type="checkbox"/> Public Works | |
| <input type="checkbox"/> Recreation | |
| <input type="checkbox"/> Resident | |
| <input type="checkbox"/> Purchasing | |

Reported/Requested By (include tel #) Ms. Davis 201-870-7508

Taken By: Nelson Wong x1505 Date: 10/2/20
 Date: 10/2/20

I. INFORMATION REQUESTED:

II. PROBLEM REPORTED:

Location: 22, 24, 26 West Englewood Ave.

Nature of Problem: Sidewalk in disrepair as per Ms. Davis complaint (see attach)

III. ACTION(S) TAKEN:

Signed: _____ Date: _____

White and Yellow Copies - Forward to appropriate department
 (Yellow to be returned to originator after action)
 Pink Copy - Retain for file

ELEVIN REAL ESTATE, LLC
172 WEST ENGLEWOOD AVE
TEANECK, NJ 07666

Abated
nw

December 20, 2018

Teaneck Health Dept
818 Teaneck Rd
Teaneck, NJ 07666

Re: Violations at 20, 22, 26 West Englewood Ave

Dear Mr. Wong,

The violations noted in the attached letter have been cleared up. Please see the attached pictures of the properties.

Thank you,
Elie Katz



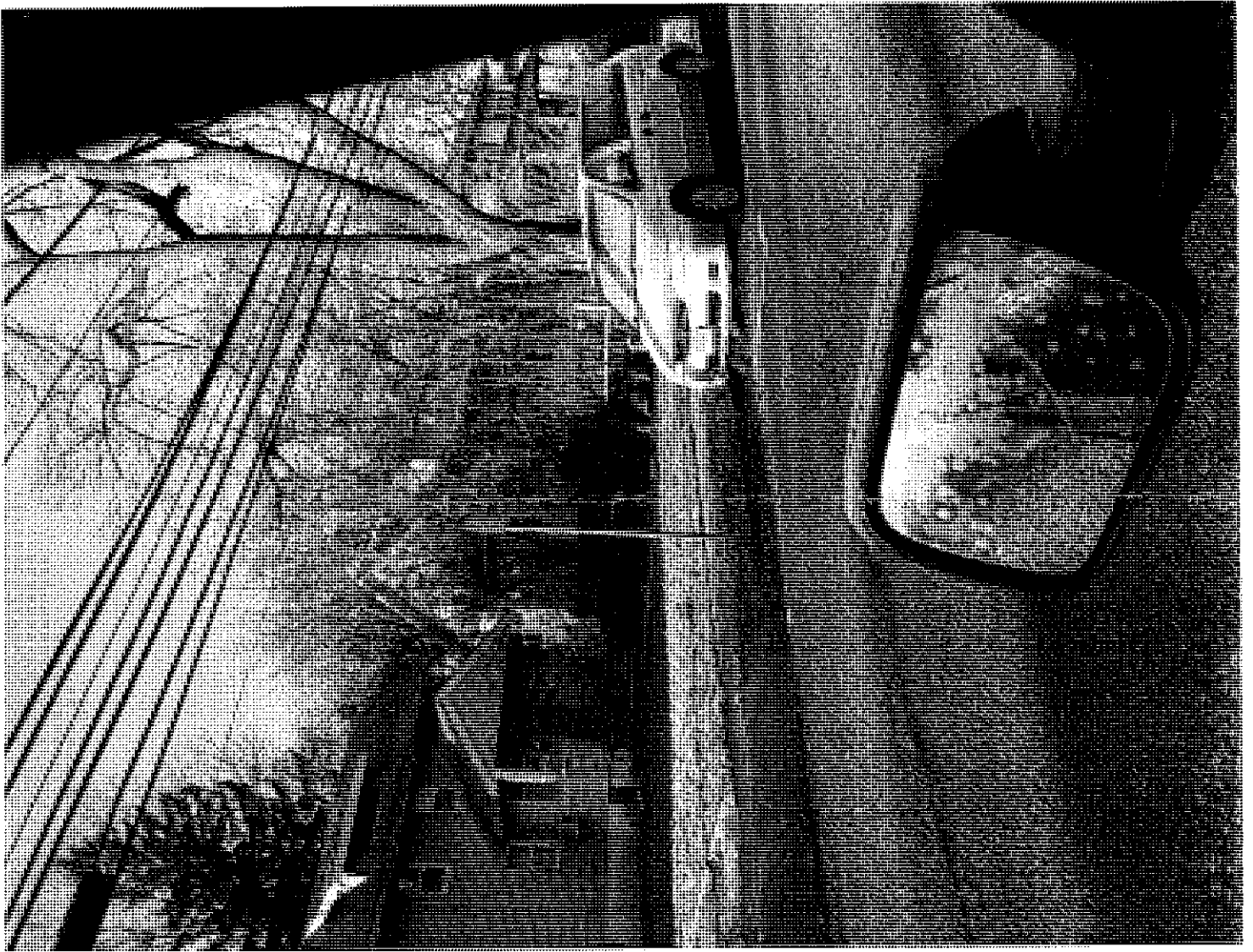

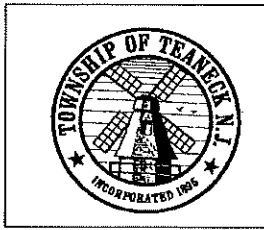

TEANECK HEALTH DEPARTMENT

818 TEANECK ROAD
TEANECK, NEW JERSEY 07666
(201) 837-1600 ext. 1500

FO
2/18

NOTICE OF VIOLATION

Abated
12/07/18

Sent Certified and Regular Mail

Date:

Re: 20, 22, 26 West Englewood, Teaneck, NJ 07666
Name: Elie Katz (ETALS)
Mailing Address: 172 West Englewood Avenue, Teaneck, NJ 07666

YOU ARE HEREBY NOTIFIED TO HAVE THE FOLLOWING CONDITION(S) REMEDIED WITHIN (10) DAYS.

| <u>Section(s):</u> | <u>Violation(s):</u> |
|--------------------|--|
| 19 - 15 xx | - Remove junk and debris from the entire property. |
| 19 - 16** xx | - Remove overgrowth, weeds, junk, debris or other matter from the entire property. |
| 29A - 15 xx | - Maintain landscaping, bushes, hedges from properties 20 & 26. Trim back the hedges obstructing some of the sidewalk. |

Please remove dead leaves, litter and debris from all 3 properties, including the curbside area (see pictures).

Re-inspection date on or after: 12 / 17 / 18

****FAILURE TO COMPLY MAY RESULT IN ENFORCEMENT ACTIONS BY THE TOWNSHIP INCLUDING THE ISSUANCE OF SUMMONS(ES) WITH A PENALTY OF UP TO \$500.00 PER CITATION AND/OR ABATEMENT OF THE VIOLATION(S) BY THE TOWNSHIP AT THE EXPENSE OF THE PROPERTY OWNER AND/OR RESPONSIBLE PARTY. THE COST OF THE ABATEMENT MAY GO UP TO \$2,500. THESE COST WILL BE APPLIED TO LABOR, OVER-TIME, EQUIPMENT, DUMPING/REMOVAL COSTS AND/OR LEGAL COSTS. THIS ACTION IS NECESSARY AS A PUBLIC HEALTH MEASURE (201) 837-1600 Ext. 1508 OR NWONG@TEANECKNJ.GOV.
IF YOU DESIRE A HEARING, YOU MUST CONTACT THE TEANECK HEALTH DEPT. PRIOR TO THE REMEDIED TIME NOTED ABOVE.**

**Nelson O. Wong
Environmental Health Specialist
Teaneck Health Department**

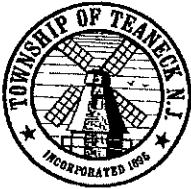

TEANECK HEALTH DEPARTMENT

818 TEANECK ROAD
TEANECK, NEW JERSEY 07666
(201) 837-1600 ext. 1500

NOTICE OF VIOLATION

Sent Certified and Regular Mail

Date:

12/ 07 / 18

Re: 20, 22, 26 West Englewood, Teaneck, NJ 07666
Name: Elie Katz (ETALS)
Mailing Address: 172 West Englewood Avenue, Teaneck, NJ 07666

YOU ARE HEREBY NOTIFIED TO HAVE THE FOLLOWING CONDITION(S) REMEDIED WITHIN (10) DAYS.

Section(s):

Violation(s):

| | |
|--------------|--|
| 19 – 15 xx | - Remove junk and debris from the entire property. |
| 19 - 16** xx | - Remove overgrowth, weeds, junk, debris or other matter from the entire property. |
| 29A – 15 xx | - Maintain landscaping, bushes, hedges from properties 20 & 26. Trim back the hedges obstructing some of the sidewalk. |

Please remove dead leaves, litter and debris from all 3 properties, including the curbside area (see pictures).

Re-inspection date on or after: 12 / 17 / 18

****FAILURE TO COMPLY MAY RESULT IN ENFORCEMENT ACTIONS BY THE TOWNSHIP INCLUDING THE ISSUANCE OF SUMMONS(ES) WITH A PENALTY OF UP TO \$500.00 PER CITATION AND/OR ABATEMENT OF THE VIOLATION(S) BY THE TOWNSHIP AT THE EXPENSE OF THE PROPERTY OWNER AND/OR RESPONSIBLE PARTY. THE COST OF THE ABATEMENT MAY GO UP TO \$2,500. THESE COST WILL BE APPLIED TO LABOR, OVER-TIME, EQUIPMENT, DUMPING/REMOVAL COSTS AND/OR LEGAL COSTS. THIS ACTION IS NECESSARY AS A PUBLIC HEALTH MEASURE (201) 837-1600 Ext. 1508 OR NWONG@TEANECKNJ.GOV. IF YOU DESIRE A HEARING, YOU MUST CONTACT THE TEANECK HEALTH DEPT. PRIOR TO THE REMEDIED TIME NOTED ABOVE.**

**Nelson O. Wong
Environmental Health Specialist
Teaneck Health Department**

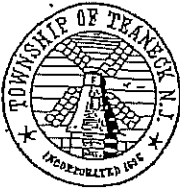

TEANECK HEALTH DEPARTMENT

818 TEANECK ROAD
TEANECK, NEW JERSEY 07666
(201) 837-1600

NW

SERVICE REQUEST

DATE: 12/7/18 TIME: 10³² A.M.

RCV'D BY: NW

COMPLAINANT'S NAME: ANONYMOUS HOME #:

ADDRESS: WORK #:

COMPLAINT: 20, 22, 26 West Englewood Ave
Leaves, litter, debris, overgrowth

Entered in log (CHECK)

FINDINGS: 12/7/18 @ 1pm

20 & 26 Bushes obstructing sidewalk.
20, 22 & 26, have dead leaves, litter and debris throughout property, including curbside.

ACTION TAKEN:
SENT notice & called owner.

SIGNED NW

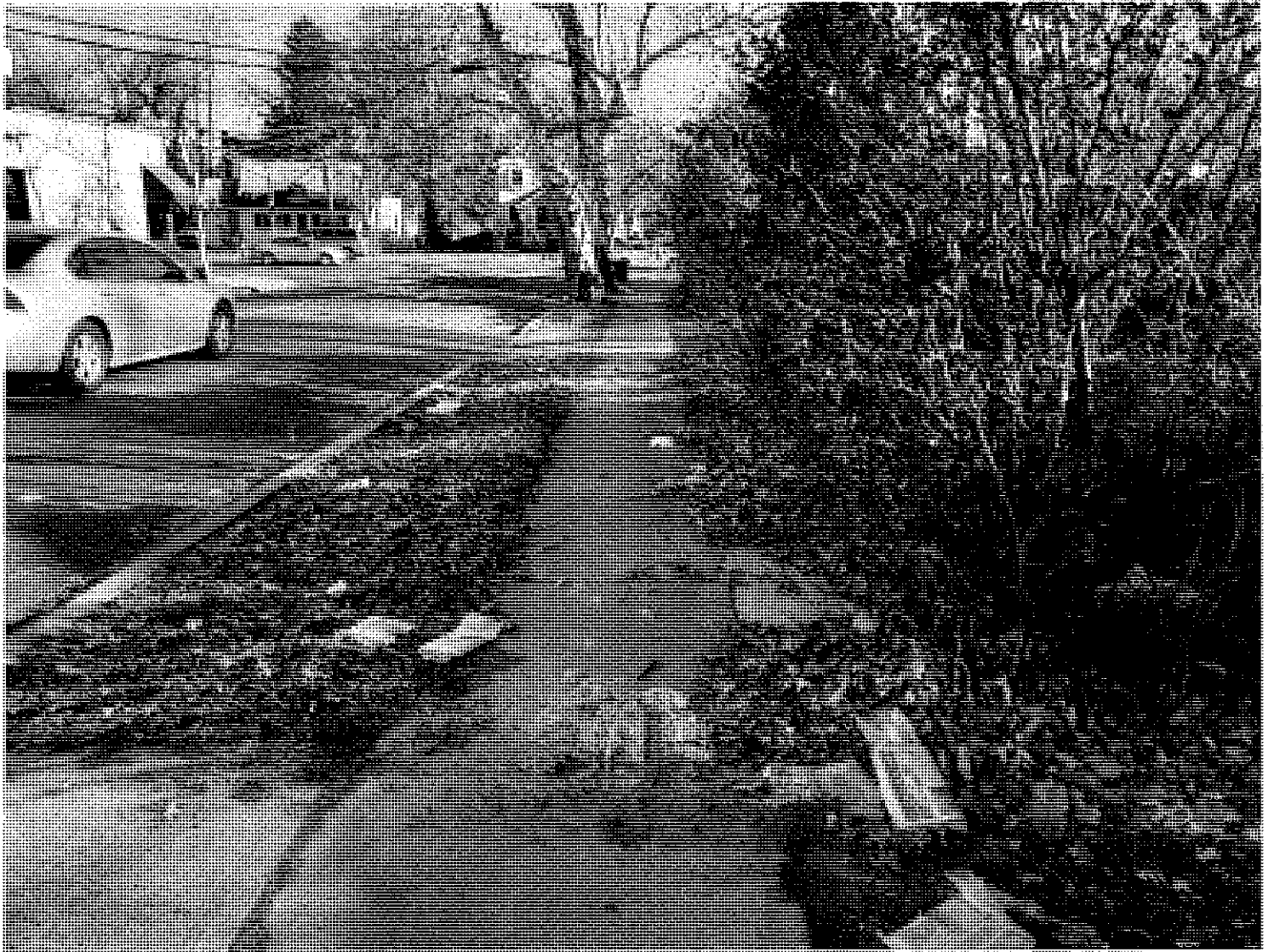





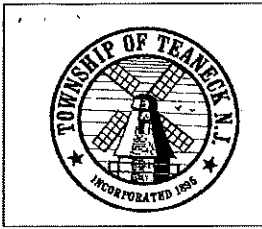

TEANECK HEALTH DEPARTMENT
 818 TEANECK ROAD
 TEANECK, NEW JERSEY 07666
 (201) 837-1600 ext. 1500

FU
 10/31
 Accepted
 10/19/18

NOTICE OF VIOLATION

Sent Certified and Regular Mail

Date:

Re: 20, 22, 26 West Englewood & Rear of business along Court Street,
 Teaneck, NJ 07666
 Name: Elie Katz (ETALS)
 Mailing Address: 172 West Englewood Avenue, Teaneck, NJ 07666

YOU ARE HEREBY NOTIFIED TO HAVE THE FOLLOWING CONDITION(S) REMEDIED WITHIN (10) DAYS.

| <u>Section(s):</u> | <u>Violation(s):</u> |
|--------------------|--|
| 19 – 15 xx | - Remove junk and debris from the entire property. |
| 19 - 16** xx | - Remove overgrowth, weeds, junk, debris or other matter from the entire property. |
| 29A – 15 xx | - Maintain landscaping, bushes, hedges, etc. |

Re-inspection date on or after: 10 / 30 / 18

****FAILURE TO COMPLY MAY RESULT IN ENFORCEMENT ACTIONS BY THE TOWNSHIP INCLUDING THE ISSUANCE OF SUMMONS(ES) WITH A PENALTY OF UP TO \$500.00 PER CITATION AND/OR ABATEMENT OF THE VIOLATION(S) BY THE TOWNSHIP AT THE EXPENSE OF THE PROPERTY OWNER AND/OR RESPONSIBLE PARTY. THE COST OF THE ABATEMENT MAY GO UP TO \$2,500. THESE COST WILL BE APPLIED TO LABOR, OVER-TIME, EQUIPMENT, DUMPING/REMOVAL COSTS AND/OR LEGAL COSTS. THIS ACTION IS NECESSARY AS A PUBLIC HEALTH MEASURE (201) 837-1600 Ext. 1508 OR NWONG@TEANECKNJ.GOV. IF YOU DESIRE A HEARING, YOU MUST CONTACT THE TEANECK HEALTH DEPT. PRIOR TO THE REMEDIED TIME NOTED ABOVE.**

**Nelson O. Wong
 Environmental Health Specialist
 Teaneck Health Department**

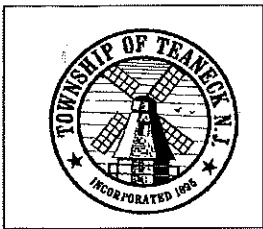

TEANECK HEALTH DEPARTMENT

818 TEANECK ROAD
TEANECK, NEW JERSEY 07666
(201) 837-1600 ext. 1500

File

NOTICE OF VIOLATION

Sent Certified and Regular Mail

Date: 10/ 19 / 18

Re: 20, 22, 26 West Englewood & Rear of business along Court Street,
Teaneck, NJ 07666
Name: Elie Katz (ETALS)
Mailing Address: 172 West Englewood Avenue, Teaneck, NJ 07666

**YOU ARE HEREBY NOTIFIED TO HAVE THE FOLLOWING CONDITION(S) REMEDIED
WITHIN (10) DAYS.**

Section(s):

Violation(s):

- 19 – 15 xx - Remove junk and debris from the entire property.
- 19 - 16** xx - **Remove** overgrowth, weeds, junk, debris or **other matter from the entire property.**
- 29A – 15 xx - Maintain landscaping, bushes, hedges, etc.

Re-inspection date on or after: 10 / 30 / 18

****FAILURE TO COMPLY MAY RESULT IN ENFORCEMENT ACTIONS BY THE TOWNSHIP INCLUDING THE ISSUANCE OF SUMMONS(ES) WITH A PENALTY OF UP TO \$500.00 PER CITATION AND/OR ABATEMENT OF THE VIOLATION(S) BY THE TOWNSHIP AT THE EXPENSE OF THE PROPERTY OWNER AND/OR RESPONSIBLE PARTY. THE COST OF THE ABATEMENT MAY GO UP TO \$2,500. THESE COST WILL BE APPLIED TO LABOR, OVER-TIME, EQUIPMENT, DUMPING/REMOVAL COSTS AND/OR LEGAL COSTS. THIS ACTION IS NECESSARY AS A PUBLIC HEALTH MEASURE (201) 837-1600 Ext. 1508 OR NWONG@TEANECKNJ.GOV.
IF YOU DESIRE A HEARING, YOU MUST CONTACT THE TEANECK HEALTH DEPT. PRIOR TO THE REMEDIED TIME NOTED ABOVE.**

**Nelson O. Wong
Environmental Health Specialist
Teaneck Health Department**

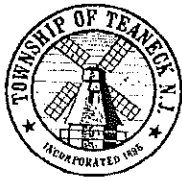

TEANECK HEALTH DEPARTMENT

818 TEANECK ROAD
TEANECK, NEW JERSEY 07666
(201) 837-1600

SERVICE REQUEST

DATE: 10/18/18 TIME: 12pm

RECV'D BY: TM

COMPLAINANT'S NAME: Anonymous HOME #: _____

ADDRESS: _____ WORK #: _____

COMPLAINT:

20 & 22 West Englewood Avenue (same owner)

overgrown bushes/garbage all over property

Entered in log (CHECK) _____

FINDINGS:

Valid

ACTION TAKEN:

Sent Violation Notice

SIGNED NW.

[New Search](#) [Assessment Postcard](#) [Property Card](#)

Block: 4905 Prop Loc: 22 W ENGLEWOOD AVE Owner: KATZ (ETALS), ELIE Y Square Ft: 1715
 Lot: 8 District: 0260 TEANECK Street: 172 W ENGLEWOOD AVE E Year Built: 1910
 Qual: Class: 2 City State: TEANECK, NJ 07666 Style: 2C

Additional Information

Prior Block: Acct Num: 045361 Addl Lots: EPL Code: 0 0 0
 Prior Lot: Mtg Acct: Land Desc: 60X185 Statute:
 Prior Qual: Bank Code: 0 Bldg Desc: 2S-F-O-3UG Initial: 000000 Further: 000000
 Updated: 01/08/15 Tax Codes: Class4Cd: 0 Desc:
 Zone: BR Map Page: Acreage: 0.2548 Taxes: 10658.11 / 0.00

Sale Information

Sale Date: 11/17/03 Book: 8644 Page: 346 Price: 260000 NU#: 0
 Sr/a Date Book Page Price NU# Ratio Grantee
[More Info](#) 11/17/03 8644 346 260000 72.69 KATZ (ETALS), ELIE Y

TAX-LIST-HISTORY

| Year | Owner Information | Land/Imp/Tot | Exemption | Assessed | Property Class |
|-------------|--|----------------------------|-----------|----------|----------------|
| <u>2018</u> | KATZ (ETALS), ELIE Y 172 W ENGLEWOOD AVE E TEANECK, NJ 07666 | 221500 114400 335900 | 0 | 335900 | 2 |
| <u>2017</u> | KATZ (ETALS), ELIE Y 172 W ENGLEWOOD AVE E TEANECK, NJ 07666 | 221500 114400 335900 | 0 | 335900 | 2 |
| <u>2016</u> | KATZ (ETALS), ELIE Y 172 W ENGLEWOOD AVE E TEANECK, NJ 07666 | 221500 114400 335900 | 0 | 335900 | 2 |
| <u>2015</u> | KATZ (ETALS), ELIE Y 172 W ENGLEWOOD AVE E TEANECK, NJ 07666 | 221500 114400 335900 | 0 | 335900 | 2 |

*Click on Underlined Year for Tax List Page

[*Click Here for More History](#)

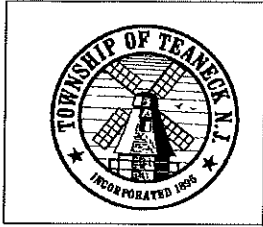

TEANECK HEALTH DEPARTMENT
 818 TEANECK ROAD
 TEANECK, NEW JERSEY 07666
 (201) 837-1600 ext. 1500

Handwritten: FU
 5/16

NOTICE OF VIOLATION

Sent Certified and Regular Mail

Date:

Handwritten: Abated
 05/04/18

Re: 20 West Englewood Avenue, Teaneck, NJ 07666 (block 4905, lot 9)
 Name: Henry Orlinsky
 Mailing Address: 172 West Englewood Avenue, Teaneck, NJ 07666

YOU ARE HEREBY NOTIFIED TO HAVE THE FOLLOWING CONDITION(S) REMEDIED WITHIN (10) DAYS.

- | <u>Section(s):</u> | <u>Violation(s):</u> |
|--------------------|---|
| 29A-13,23 xx | - Exterior is blighted, deteriorated, and/or inadequately maintained. REPAIR/REPLACE DAMAGED FENCE LOCATED ON THE EAST SIDE OF YOUR PROPERTY. |
| 19 - 16** xx | - Remove overgrowth, weeds, junk, debris or other matter from the entire property. REMOVE GARBAGE, JUNK, AND DEBRIS FROM THE ENTIRE PROPERTY. |

PLEASE ALSO CHECK 22 & 26 FOR THIS SAME VIOLATION.

Re-inspection date on or after: 05/ 16 / 18

****FAILURE TO COMPLY MAY RESULT IN ENFORCEMENT ACTIONS BY THE TOWNSHIP INCLUDING THE ISSUANCE OF SUMMONS(ES) WITH A PENALTY OF UP TO \$500.00 PER CITATION AND/OR ABATEMENT OF THE VIOLATION(S) BY THE TOWNSHIP AT THE EXPENSE OF THE PROPERTY OWNER AND/OR RESPONSIBLE PARTY. THE COST OF THE ABATEMENT MAY GO UP TO \$2,500. THESE COST WILL BE APPLIED TO LABOR, OVER-TIME, EQUIPMENT, DUMPING/REMOVAL COSTS AND/OR LEGAL COSTS. THIS ACTION IS NECESSARY AS A PUBLIC HEALTH MEASURE (201) 837-1600 Ext. 1508 OR NWONG@TEANECKNJ.GOV. IF YOU DESIRE A HEARING, YOU MUST CONTACT THE TEANECK HEALTH DEPT. PRIOR TO THE REMEDIED TIME NOTED ABOVE.**

**Nelson O. Wong
 Environmental Health Specialist
 Teaneck Health Department**

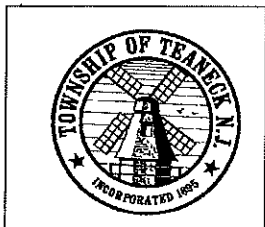

TEANECK HEALTH DEPARTMENT

818 TEANECK ROAD
TEANECK, NEW JERSEY 07666
(201) 837-1600 ext. 1500

File

NOTICE OF VIOLATION

Sent Certified and Regular Mail

Date:

05/ 04 / 18

Re: 20 West Englewood Avenue, Teaneck, NJ 07666 (block 4905, lot 9)
Name: Henry Orlinsky
Mailing Address: 172 West Englewood Avenue, Teaneck, NJ 07666

YOU ARE HEREBY NOTIFIED TO HAVE THE FOLLOWING CONDITION(S) REMEDIED WITHIN (10) DAYS.

Section(s):

Violation(s):

29A-13,23 xx - Exterior is blighted, deteriorated, and/or inadequately maintained.

REPAIR/REPLACE DAMAGED FENCE LOCATED ON THE EAST SIDE OF YOUR PROPERTY.

19 - 16** xx - **Remove** overgrowth, weeds, junk, debris or other matter from the entire property.

REMOVE GARBAGE, JUNK, AND DEBRIS FROM THE ENTIRE PROPERTY.

PLEASE ALSO CHECK 22 & 26 FOR THIS SAME VIOLATION.

Re-inspection date on or after: 05/ 16 / 18

****FAILURE TO COMPLY MAY RESULT IN ENFORCEMENT ACTIONS BY THE TOWNSHIP INCLUDING THE ISSUANCE OF SUMMONS(ES) WITH A PENALTY OF UP TO \$500.00 PER CITATION AND/OR ABATEMENT OF THE VIOLATION(S) BY THE TOWNSHIP AT THE EXPENSE OF THE PROPERTY OWNER AND/OR RESPONSIBLE PARTY. THE COST OF THE ABATEMENT MAY GO UP TO \$2,500. THESE COST WILL BE APPLIED TO LABOR, OVER-TIME, EQUIPMENT, DUMPING/REMOVAL COSTS AND/OR LEGAL COSTS. THIS ACTION IS NECESSARY AS A PUBLIC HEALTH MEASURE (201) 837-1600 Ext. 1508 OR NWONG@TEANECKNJ.GOV. IF YOU DESIRE A HEARING, YOU MUST CONTACT THE TEANECK HEALTH DEPT. PRIOR TO THE REMEDIED TIME NOTED ABOVE.**

Nelson O. Wong
Environmental Health Specialist
Teaneck Health Department

Fwd: New Report It Notification

NW

From: Ken Katter <kkatter@teanecknj.gov>

To: ccaviness@teanecknj.gov

Cc: fgarcia@teanecknj.gov, nwong@teanecknj.gov, tmereos@teanecknj.gov, KEN KATTER <kkatter@teanecknj.gov>, wbroughton@teanecknj.gov, dkazinci@teanecknj.gov

Date: 4/18/2018 2:00 PM

CC

Please handle accordingly
Provide me with a copy of violation notice
Please update reportit app

Thanks

Sent from my iPhone

Begin forwarded message:

1 1348 Teaneck Rd 1352

2 23 Orchard St

3 20 W. Englewood Ave

From: notification@reportit.com
Date: April 18, 2018 at 1:50:22 PM EDT
To: rgoodman@teanecknj.gov, health@teanecknj.gov
Subject: New Report It Notification

ReportIt

New Report it Notification

A report has been submitted to Report it.

Short report:

Nature of Issue or Concern: Property Maintenance

I am Reporting As: Other - I'd rather not say

Location Of Incident: Teaneck Rd, Teaneck

Location Coordinates: 40.8981176379081, -74.0003678028719 Map

Comment: 1348 Teaneck Road Building Building In right side and Rear requires Painting and in Violation Of Township Codes This Entire Building And neighboring ones need Review for Multiple visible Violations Rusting vent pipe about to break and collapse at Rear Also And Parking Lot in Rear requires paving and Lot not striped for parking as required and arrow detailing directions not on pavement as required to code. Debris In Rear Of. Building including containers requires removal and fence Broken needs repair missing parts fence broken in rear lot and missing parts same for Adjoining neighbors.

To view this report in the Report Management Dashboard use this link:

<https://admin.reportit.com/Report/ReportDashboard?defaultReportId=5767>

To view full report follow this link (Classic View):

<https://admin.reportit.com/Report/View/5767>

If you experience a problem or require assistance, please let us know.
Email, support@reportit.com or by telephone, 631-337-2251.

THANK YOU

* REPORT IT does not make any representation
to the truth or accuracy of this report.

*****DISCLAIMER*****

This message is intended only for the use of the person(s) ("Intended Recipient") to whom it is addressed. It may contain information, which is privileged and confidential. Accordingly any dissemination, distribution, copying or other use of this message or any of its content by any person other than the Intended Recipient is strictly prohibited. If you are not the Intended Recipient, please contact the sender as soon as possible and delete this message from your email.

[New Search](#) [Assessment Postcard](#) [Property Card](#)

Block: 4905 Prop Loc: 20 W ENGLEWOOD AVE Owner: KATZ, ELIE & ORLINSKY, HENRY Square Ft: 1548
 Lot: 9 District: 0260 TEANECK Street: 172 W ENGLEWOOD AVE Year Built: 1930
 Qual: Class: 2 City State: TEANECK, NJ 07666 Style: 2C

Additional Information

Prior Block: Acct Num: 045366 Addl Lots: EPL Code: 0 0 0
 Prior Lot: Mtg Acct: Land Desc: 50X180 Statute:
 Prior Qual: Bank Code: 1516 Bldg Desc: 2S-F-O-2UG Initial: 000000 Further: 000000
 Updated: 01/07/15 Tax Codes: Class4Cd: 0 Desc:
 Zone: BR Map Page: Acreage: 0.2066 Taxes: 9957.02 / 0.00

Sale Information

Sale Date: 06/29/01 Book: 8388 Page: 244 Price: 1 NU#: 4

| Serial | Date | Book | Page | Price | NU# | Ratio | Grantee |
|---------------------------|----------|------|------|--------|-----|--------|-----------------------------|
| More Info | 11/21/95 | 7844 | 568 | 1 | 25 | 999.99 | MASAI, PAUL & YVONNE |
| More Info | 04/03/00 | 8272 | 931 | 100000 | 12 | 154.30 | H.R. TAYLOR DEVELOPMENT,LLC |
| More Info | 10/12/00 | 8340 | 572 | 160000 | | 96.43 | KATZ, ELIE & MINDY ORLINSKY |
| More Info | 06/29/01 | 8388 | 244 | 1 | 4 | 999.99 | KATZ (ETALS), ELIE |

TAX-LIST-HISTORY

| Year | Owner Information | Land/Imp/Tot | Exemption | Assessed | Property Class |
|-------------|--|--------------|-----------|----------|----------------|
| <u>2018</u> | KATZ, ELIE & ORLINSKY, HENRY 172 W ENGLEWOOD AVE TEANECK, NJ 07666 | 197600 | 0 | 316800 | 2 |
| <u>2017</u> | KATZ, ELIE & ORLINSKY, HENRY 172 W ENGLEWOOD AVE TEANECK, NJ 07666 | 197600 | 0 | 316800 | 2 |
| <u>2016</u> | KATZ, ELIE & ORLINSKY, HENRY 172 W ENGLEWOOD AVE TEANECK, NJ 07666 | 197600 | 0 | 316800 | 2 |
| <u>2015</u> | KATZ, ELIE & ORLINSKY, HENRY 172 W ENGLEWOOD AVE TEANECK, NJ 07666 | 197600 | 0 | 316800 | 2 |

*Click on Underlined Year for Tax List Page

[*Click Here for More History](#)

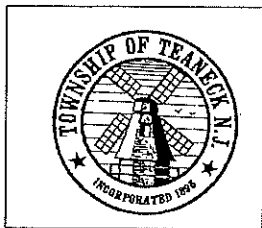

TEANECK HEALTH DEPARTMENT
 818 TEANECK ROAD
 TEANECK, NEW JERSEY 07666
 (201) 837-1600

PO 4/23

201-600-8549

NOTICE OF VIOLATION

*4/15/21
 Owner called
 03/31
 4/23/21
 Maint w/*

FINAL NOTICE BEFORE COURT SUMMONSES ARE ISSUED.

Date: _____
 Re: 1364 Teaneck Road, Teaneck, NJ 07666 (block 4905, lot 11)
 Name: Sung Mook Im & Young Im
 Mailing Address: 313 East Central Blvd., Palisade Park, NJ 07650

YOU ARE HEREBY NOTIFIED TO HAVE THE FOLLOWING CONDITION(S) REMEDIED WITHIN 10 DAYS.

| <u>Section(s):</u> | <u>Violation(s):</u> |
|--------------------|--|
| 29A - 13, 23 XX | Exterior is blighted, deteriorated, and/or inadequately maintained. |
| | PLEASE REMOVE GRAFFTTI FROM YOUR STORE FRONT (SEE PICTURE ATTACHED). |

RE-INSPECTION DATE ON OR AFTER: 04/ 12 /21

****FAILURE TO COMPLY MAY RESULT IN ENFORCEMENT ACTIONS BY THE TOWNSHIP INCLUDING THE ISSUANCE OF SUMMONS(ES) WITH A PENALTY OF UP TO \$500.00 PER CITATION AND/OR ABATEMENT OF THE VIOLATION(S) BY THE TOWNSHIP AT THE EXPENSE OF THE PROPERTY OWNER AND/OR RESPONSIBLE PARTY. THE COST OF THE ABATEMENT MAY GO UP TO \$2,500. THESE COST WILL BE APPLIED TO LABOR, OVER-TIME, EQUIPMENT, DUMPING/REMOVAL COSTS AND/OR LEGAL COSTS. THIS ACTION IS NECESSARY AS A PUBLIC HEALTH MEASURE (201) 837-1600 Ext. 1508 OR NWONG@TEANECKNJ.GOV. IF YOU DESIRE A HEARING, YOU MUST CONTACT THE TEANECK HEALTH DEPT. PRIOR TO THE REMEDIED TIME NOTED ABOVE.**

**Nelson O. Wong
 Environmental Health Specialist
 Teaneck Health Department**

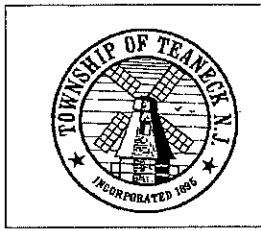

TEANECK HEALTH DEPARTMENT

818 TEANECK ROAD
TEANECK, NEW JERSEY 07666
(201) 837-1600

FO
3/29
Not Done

NOTICE OF VIOLATION

Sent Certified and Regular Mail

03/ 16 /21

Date:

Re: 1364 Teaneck Road, Teaneck, NJ 07666 (block 4905, lot 11)

Name: Sung Mook Im & Young Im

Mailing Address: 313 East Central Blvd., Palisade Park, NJ 07650

YOU ARE HEREBY NOTIFIED TO HAVE THE FOLLOWING CONDITION(S) REMEDIED WITHIN 10 DAYS.

Section(s):

Violation(s):

29A - 13, 23 XX Exterior is blighted, deteriorated, and/or inadequately maintained.

PLEASE REMOVE GRAFFTTI FROM YOUR STORE FRONT (SEE PICTURE ATTACHED).

RE-INSPECTION DATE ON OR AFTER: 03/ 29 /21

****FAILURE TO COMPLY MAY RESULT IN ENFORCEMENT ACTIONS BY THE TOWNSHIP INCLUDING THE ISSUANCE OF SUMMONS(ES) WITH A PENALTY OF UP TO \$500.00 PER CITATION AND/OR ABATEMENT OF THE VIOLATION(S) BY THE TOWNSHIP AT THE EXPENSE OF THE PROPERTY OWNER AND/OR RESPONSIBLE PARTY. THE COST OF THE ABATEMENT MAY GO UP TO \$2,500. THESE COST WILL BE APPLIED TO LABOR, OVER-TIME, EQUIPMENT, DUMPING/REMOVAL COSTS AND/OR LEGAL COSTS.**

THIS ACTION IS NECESSARY AS A PUBLIC HEALTH MEASURE (201) 837-1600 Ext. 1508 OR NWONG@TEANECKNJ.GOV.

IF YOU DESIRE A HEARING, YOU MUST CONTACT THE TEANECK HEALTH DEPT. PRIOR TO THE REMEDIED TIME NOTED ABOVE.

Nelson O. Wong
Environmental Health Specialist
Teaneck Health Department

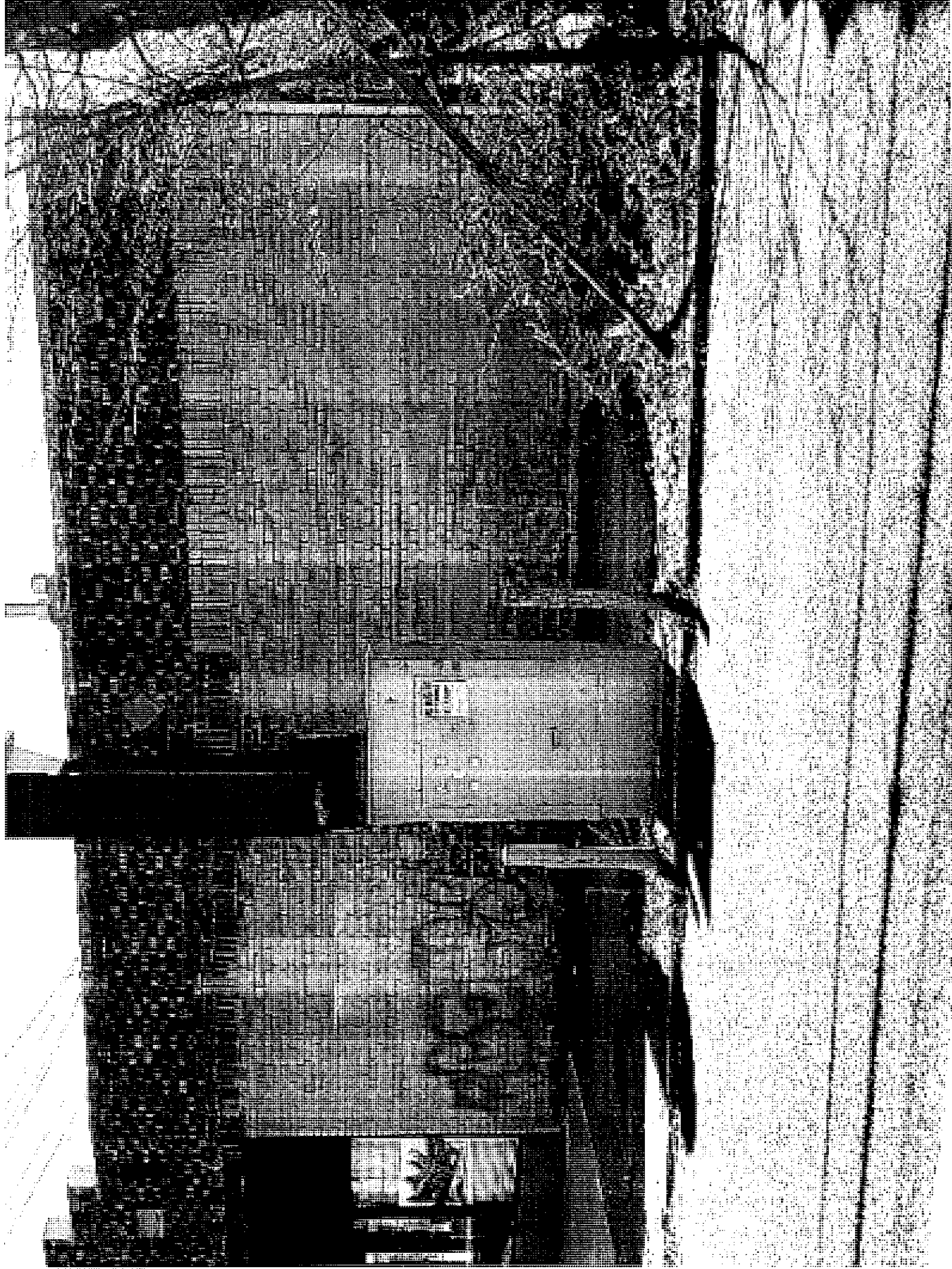

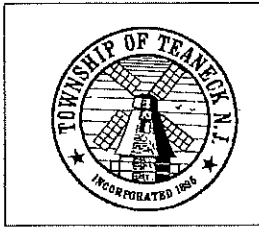

TEANECK HEALTH DEPARTMENT

818 TEANECK ROAD
TEANECK, NEW JERSEY 07666
(201) 837-1600

NOTICE OF VIOLATION

File
Abated

Sent Certified and Regular Mail

03/ 16 /21

Date:

Re: 1364 Teaneck Road, Teaneck, NJ 07666 (block 4905, lot 11)

Name: Sung Mook Im & Young Im

Mailing Address: 313 East Central Blvd., Palisade Park, NJ 07650

YOU ARE HEREBY NOTIFIED TO HAVE THE FOLLOWING CONDITION(S) REMEDIED WITHIN 10 DAYS.

Section(s):

Violation(s):

29A - 13, 23 XX

Exterior is blighted, deteriorated, and/or inadequately maintained.

PLEASE REMOVE GRAFFTTI FROM YOUR STORE FRONT (SEE PICTURE ATTACHED).

RE-INSPECTION DATE ON OR AFTER: 03/ 29 /21

****FAILURE TO COMPLY MAY RESULT IN ENFORCEMENT ACTIONS BY THE TOWNSHIP INCLUDING THE ISSUANCE OF SUMMONS(ES) WITH A PENALTY OF UP TO \$500.00 PER CITATION AND/OR ABATEMENT OF THE VIOLATION(S) BY THE TOWNSHIP AT THE EXPENSE OF THE PROPERTY OWNER AND/OR RESPONSIBLE PARTY. THE COST OF THE ABATEMENT MAY GO UP TO \$2,500. THESE COST WILL BE APPLIED TO LABOR, OVER-TIME, EQUIPMENT, DUMPING/REMOVAL COSTS AND/OR LEGAL COSTS. THIS ACTION IS NECESSARY AS A PUBLIC HEALTH MEASURE (201) 837-1600 Ext. 1508 OR NWONG@TEANECKNJ.GOV. IF YOU DESIRE A HEARING, YOU MUST CONTACT THE TEANECK HEALTH DEPT. PRIOR TO THE REMEDIED TIME NOTED ABOVE.**

Nelson O. Wong
Environmental Health Specialist
Teaneck Health Department

Re: Graffiti-1364 Teaneck Rd.-Property Maint.

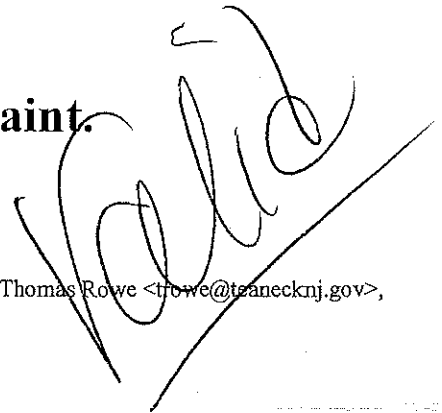

From: Ken Katter <kkatter@teanecknj.gov>
To: Nelson Wong <nwong@teanecknj.gov>
Cc: Curtis Caviness <ccaviness@teanecknj.gov>, Kevin Arahill <karahill@teanecknj.gov>, Thomas Rowe <trowe@teanecknj.gov>, KEN KATTER <kkatter@teanecknj.gov>
Date: 3/15/2021 9:21 AM

Nelson:

See below for handling

I believe this is 1364 Teaneck Rd. (corner of TR and W Englewood)

Thanks

Ken Katter, Health Officer, CPM

Work #(201) 837-1600 (x1502)
Fax #(201) 837-4817

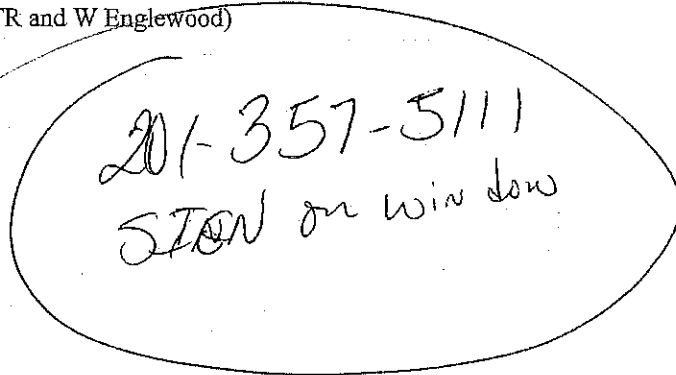

* For after hours emergencies, call the Teaneck Police Dept. at (201) 837-2600 (Weekdays after 5:15PM/Weekends/Holidays)

This email and any files transmitted with it are privileged and confidential and may be considered advisory, consultative and deliberative material under OPRA. This communication is intended solely for the use of the individual or entity to whom they are addressed. If you have received this email in error, please notify the system manager. This message contains confidential information and is intended only for the individual named. If you are not the named addressee you should not disseminate, distribute or copy this email. Please notify the sender immediately by email if you have received this email by mistake, please delete this email from your system. If you are not the intended recipient you are notified that disclosing, copying, distributing or taking any action in reliance on the contents of this information is strictly prohibited.

From: Kevin Arahill <karahill@teanecknj.gov>
To: Thomas Rowe <trowe@teanecknj.gov>
Cc: Ken Katter <kkatter@teanecknj.gov>, Curtis Caviness <ccaviness@teanecknj.gov>
Sent: 3/14/2021 9:35 PM
Subject: Re: Graffiti

Private building copying Health Dept.

Kevin Arahill, CPWM, CRP
Director of Public Works
Teaneck, NJ
(201) 837-1600 Ext. 1701

> On Mar 14, 2021, at 8:04 PM, Thomas Rowe <trowe@teanecknj.gov> wrote:

>
> Is this private property or Township property?
> If private, I will contact the owner to clean.

>
> Thomas P. Rowe
> Deputy Manager
> Teaneck Twp.
> 201.837.1600

>
>
>

> Begin forwarded message:

>
>> From: Elie Katz <katz07666@gmail.com>
>> Date: March 14, 2021 at 6:44:08 PM EDT
>> To: Tom Rowe <trowe@teanecknj.gov>, Katz Council Email <katz07666@teanecknj.gov>
>> Subject: Fwd: Graffiti

>>
>> This is the commercial building on the south west corner of West Englewood and Teaneck Road.
>>
>>

>> Begin forwarded message:

>>
>>> From: MALIKAH TEAL <malikaht@verizon.net>
>>> Date: March 14, 2021 at 12:49:51 PM EDT
>>> To: katz07666@gmail.com
>>> Subject: Fwd: Graffiti
>>> Reply-To: MALIKAH TEAL <malikaht@verizon.net>

>>>
>>>

>>> Good Afternoon,
>>> I just wanted to follow up in regards to the graffiti on the building on Teaneck road (see below emails). As of today the graffiti is still there. Any word when it will be removed or covered up?

>>>
>>> Thank you,
>>> MalikaH Teal

>>>
>>>
>>>

>>> -----Original Message-----

>>> From: Elie Katz <katz07666@gmail.com>

>>> To: MALIKAH TEAL <malikaht@verizon.net>; Katz Council Email <katz07666@teanecknj.gov>

>>> Sent: Fri, Oct 30, 2020 5:07 pm

>>> Subject: Re: Graffiti

>>>

>>> DPW will remove on Monday. Please keep me posted--Elie

>>>

>>>> On Mon, Oct 26, 2020 at 9:12 PM MALIKAH TEAL <malikaht@verizon.net> wrote:

>>> Hi i read your emails often and i thank you for all the information provided. I noticed a change in our town and surrounding towns. Not for the better. I was wondering if the issue of graffit on buildings have been addressed? It seems to be the same tag on the buildings. Ive attached a photo. This tag is on a few buildings up and down Teaneck road and i was wondering if the issue has been addressed?

>>> Thank you.

>

>

> This email and any files transmitted with it are privileged and confidential and may be considered
> advisory, consultative and deliberative material under OPRA. This communication is intended solely
> for the use of the individual or entity to whom they are addressed. If you have received this email
> in error please notify the system manager. This message contains confidential information and is
> intended only for the individual named. If you are not the named addressee you should not
> disseminate, distribute or copy this email. Please notify the sender immediately by email if you have
> received this email by mistake and delete this email from your system. If you are not the intended recipient
> you are notified that disclosing, copying, distributing or taking any action in reliance on the contents of
> this information is strictly prohibited.

>

[New Search](#) [Assessment Postcard](#) [Property Card](#)

| | | | |
|------------------------|---------------------------|-------------------------------------|---------------------------------|
| Block: 4905 | Prop Loc: 1364 TEANECK RD | Owner: IM, SUNG MOOK & YOUNG IM | Square Ft: 0 |
| Lot: 11 | District: 0260 TEANECK | Street: 313 EAST CENTRAL BLVD | Year Built: 0000 |
| Qual: C0003 | Class: 4A | City State: PALISADE PARK, NJ 07650 | Style: |
| Additional Information | | | |
| Prior Block: | Acct Num: | Add Lots: | EPL Code: 0 0 0 |
| Prior Lot: | Mtg Acct: | Land Desc: .0362 | Statute: |
| Prior Qual: | Bank Code: 0 | Bldg Desc: CONDO | Initial: 000000 Further: 000000 |
| Updated: 05/15/17 | Tax Codes: | Class4Cd: 739 | Desc: |
| Zone: BR | Map Page: | Acreage: 0.0362 | Taxes: 6131.66 / 0.00 |

Sale Information

| | | | | | |
|---------------------------|-------------|-------------|---------------|--------------|--|
| Sale Date: 05/11/05 | Book: 8813 | Page: 275 | Price: 180000 | NU#: 0 | |
| <u>Sr1a</u> | <u>Date</u> | <u>Book</u> | <u>Page</u> | <u>Price</u> | <u>NU#</u> <u>Ratio</u> <u>Grantee</u> |
| More Info | 03/01/04 | 8666 | 953 | 170000 | 77.82 HOUNG, SOON JA |
| More Info | 05/11/05 | 8813 | 275 | 180000 | 73.50 IM, SUNG MOOK & YOUNG IM |

TAX-LIST-HISTORY

| Year | Owner Information | Land/Imp/Tot | Exemption | Assessed | Property Class |
|-------------|--|--------------|-----------|----------|----------------|
| <u>2021</u> | IM, SUNG MOOK & YOUNG IM 313 EAST CENTRAL BLVD PALISADE PARK, NJ 07650 | 68900 | 0 | 189600 | 4A |
| <u>2020</u> | IM, SUNG MOOK & YOUNG IM 313 EAST CENTRAL BLVD PALISADE PARK, NJ 07650 | 68900 | 0 | 189600 | 4A |
| <u>2019</u> | IM, SUNG MOOK & YOUNG IM 313 EAST CENTRAL BLVD PALISADE PARK, NJ 07650 | 68900 | 0 | 189600 | 4A |
| <u>2018</u> | IM, SUNG MOOK & YOUNG IM 313 EAST CENTRAL BLVD PALISADE PARK, NJ 07650 | 68900 | 0 | 189600 | 4A |

*Click on Underlined Year for Tax List Page

[*Click Here for More History](#)



1364 Teaneck Rd.
3/15/21

Fwd: New Report It Notification

From: Ken Katter <kkatter@teanecknj.gov>

To: ccaviness@teanecknj.gov

Cc: fgarcia@teanecknj.gov, nwong@teanecknj.gov, tmereos@teanecknj.gov, KEN KATTER <kkatter@teanecknj.gov>, wbroughton@teanecknj.gov, dkazinci@teanecknj.gov

Date: 4/18/2018 2:00 PM

NW

1352

CC

1 1348 Teaneck Rd
2 [Redacted] Orchard St
3 [Redacted] W Englewood Ave

Please handle accordingly
Provide me with a copy of violation notice
Please update reportit app

Thanks

Sent from my iPhone

Begin forwarded message:

From: notification@reportit.com
Date: April 18, 2018 at 1:50:22 PM EDT
To: rgoodinan@teanecknj.gov, health@teanecknj.gov
Subject: New Report It Notification

ReportIt

New Report it Notification

A report has been submitted to Report it.

Short report:

Nature of Issue or Concern: Property Maintenance

I am Reporting As: Other - I'd rather not say

Location Of Incident: Teaneck Rd, Teaneck

Location Coordinates: 40.8981176379081, -74.0003678028719 Map

Comment: 1348 Teaneck Road Building Building In right side and Rear requires Painting and in Violation Of Township Codes This Entire Building And neighboring ones need Review for Multiple visable Violations Rusting vent pipe about to break and collapse at Rear Also And Parking Lot in Rear requires paving and Lot not striped for parking as required and arrow detailing directions not on pavement as required to code. Debris In Rear Of. Building including containers requires removal and fence Broken needs repair missing parts fence broken in rear lot and missing parts same for Adjoining neighbors.

To view this report in the Report Management Dashboard use this link:

| | | |
|----------------------------|-------------------------------------|-------------------------------|
| New Search | Assessment Postcard | Property Card |
|----------------------------|-------------------------------------|-------------------------------|

| | | | |
|-------------|--------------------------------|-------------------------------|------------------|
| Block: 4905 | Prop Loc: 1348-1352 TEANECK RD | Owner: JALASAI LLC | Square Ft: 0 |
| Lot: 13 | District: 0260 TEANECK | Street: 1356 TEANECK ROAD | Year Built: 0000 |
| Qual: | Class: 4A | City State: TEANECK, NJ 07666 | Style: |

Additional Information

| | | | |
|-------------------|------------------|-------------------|---------------------------------|
| Prior Block: | Acct Num: 045386 | Add Lots: | EPL Code: 0 0 0 |
| Prior Lot: | Mtg Acct: | Land Desc: 66X145 | Statute: |
| Prior Qual: | Bank Code: 0 | Bldg Desc: 1S-B-A | Initial: 000000 Further: 000000 |
| Updated: 05/01/15 | Tax Codes: | Class4Cd: 739 | Desc: |
| Zone: BR | Map Page: | Acreage: 0.2197 | Taxes: 16123.59 / 0.00 |

Sale Information

Sale Date: 06/19/14 Book: 1734 Page: 1938 Price: 700000 NU#: 0

| Src | Date | Book | Page | Price | NU # | Ratio | Grantee |
|---------------------------|----------|------|------|--------|------|-------|-------------------------------|
| More Info | 06/19/14 | 1734 | 1938 | 700000 | | 81.42 | JALASAI LLC |
| More Info | 01/27/03 | 8556 | 32 | 390000 | | 75.07 | GUERIN(TRUSTEES/ETAL), EUGENE |

TAX-LIST-HISTORY

| Year | Owner Information | Land/Imp/Tot | Exemption | Assessed | Property Class |
|-------------|---|----------------------------|-----------|----------|----------------|
| <u>2018</u> | JALASAI LLC 1356 TEANECK ROAD TEANECK, NJ 07666 | 309000 204000 513000 | 0 | 513000 | 4A |
| <u>2017</u> | JALASAI LLC 1356 TEANECK ROAD TEANECK, NJ 07666 | 309000 204000 513000 | 0 | 513000 | 4A |
| <u>2016</u> | JALASAI LLC 1356 TEANECK ROAD TEANECK, NJ 07666 | 309000 204000 513000 | 0 | 513000 | 4A |
| <u>2015</u> | JALASAI LLC 1348 TEANECK ROAD TEANECK, NJ 07666 | 309000 204000 513000 | 0 | 513000 | 4A |

*Click on Underlined Year for Tax List Page

[*Click Here for More History](#)

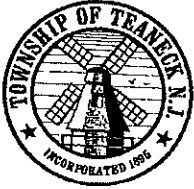

TEANECK HEALTH DEPARTMENT

818 TEANECK ROAD
TEANECK, NEW JERSEY 07666
(201) 837-1600 ext. 1500

Abated
04/11/18
23

NOTICE OF VIOLATION

Sent Certified and Regular Mail

Date:

Re: 1348 – 1352 Teaneck Road, Teaneck, NJ 07666 (4905, lot 13)

Name: Jalasai LLC

Mailing Address: 1356 Teaneck Road, Teaneck, NJ 07666

YOU ARE HEREBY NOTIFIED TO HAVE THE FOLLOWING CONDITION(S) REMEDIED WITHIN (10) DAYS.

Section(s):
19-2 XX
19 – 15 XX
19 - 16** XX

Violation(s):
- Uncovered debris and/or uncovered trash receptacle
- Remove debris from property.
- **Remove** garbage, litter, debris, and other **other matter**.

PLEASE CLEAN UP THE ENTIRE REAR PARKING LOT ON A REGULAR BASIS. BE ADVISED THAT COURT SUMMONSES WILL BE ISSUED IF THESE CONDITONS CONTINUE.

Re-inspection date on or after: 04/ 22 / 17

****FAILURE TO COMPLY MAY RESULT IN ENFORCEMENT ACTIONS BY THE TOWNSHIP INCLUDING THE ISSUANCE OF SUMMONS(ES) WITH A PENALTY OF UP TO \$500.00 PER CITATION AND/OR ABATEMENT OF THE VIOLATION(S) BY THE TOWNSHIP AT THE EXPENSE OF THE PROPERTY OWNER AND/OR RESPONSIBLE PARTY. THE COST OF THE ABATEMENT MAY GO UP TO \$2,500. THESE COST WILL BE APPLIED TO LABOR, OVER-TIME, EQUIPMENT, DUMPING/REMOVAL COSTS AND/OR LEGAL COSTS. THIS ACTION IS NECESSARY AS A PUBLIC HEALTH MEASURE (201) 837-1600 Ext. 1508 OR NWONG@TEANECKNJ.GOV.
IF YOU DESIRE A HEARING, YOU MUST CONTACT THE TEANECK HEALTH DEPT. PRIOR TO THE REMEDIED TIME NOTED ABOVE.**

**Nelson O. Wong
Environmental Health Specialist
Teaneck Health Department**

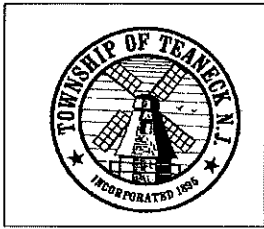

TEANECK HEALTH DEPARTMENT

818 TEANECK ROAD
TEANECK, NEW JERSEY 07666
(201) 837-1600 ext. 1500

NOTICE OF VIOLATION

Sent Certified and Regular Mail

Date: 04 / 11 / 18

Re: 1348 – 1352 Teaneck Road, Teaneck, NJ 07666 (4905, lot 13)

Name: Jalasai LLC

Mailing Address: 1356 Teaneck Road, Teaneck, NJ 07666

**YOU ARE HEREBY NOTIFIED TO HAVE THE FOLLOWING CONDITION(S) REMEDIED
WITHIN (10) DAYS.**

Section(s):

19-2 XX
19 – 15 XX
19 - 16** XX

Violation(s):

- Uncovered debris and/or uncovered trash receptacle
- Remove debris from property.
- **Remove** garbage, litter, debris, and other **other matter**.

**PLEASE CLEAN UP THE ENTIRE REAR PARKING LOT ON
A REGULAR BASIS. BE ADVISED THAT COURT
SUMMONSES WILL BE ISSUED IF THESE CONDITONS
CONTINUE.**

Re-inspection date on or after: 04/ 22 / 17

****FAILURE TO COMPLY MAY RESULT IN ENFORCEMENT ACTIONS BY THE TOWNSHIP INCLUDING THE
ISSUANCE OF SUMMONS(ES) WITH A PENALTY OF UP TO \$500.00 PER CITATION AND/OR ABATEMENT OF
THE VIOLATION(S) BY THE TOWNSHIP AT THE EXPENSE OF THE PROPERTY OWNER AND/OR
RESPONSIBLE PARTY. THE COST OF THE ABATEMENT MAY GO UP TO \$2,500. THESE COST WILL BE
APPLIED TO LABOR, OVER-TIME, EQUIPMENT, DUMPING/REMOVAL COSTS AND/OR LEGAL COSTS.
THIS ACTION IS NECESSARY AS A PUBLIC HEALTH MEASURE (201) 837-1600 Ext. 1508 OR
NWONG@TEANECKNJ.GOV.**

**IF YOU DESIRE A HEARING, YOU MUST CONTACT THE TEANECK HEALTH DEPT. PRIOR TO THE
REMEDIED TIME NOTED ABOVE.**

**Nelson O. Wong
Environmental Health Specialist
Teaneck Health Department**

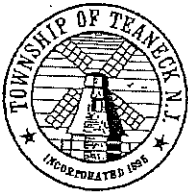

TEANECK HEALTH DEPARTMENT

818 TEANECK ROAD
TEANECK, NEW JERSEY 07666
(201) 837-1600

NW

SERVICE REQUEST

COMPLAINANT'S NAME: Resident DATE: 4/11/18 TIME: 1pm
RECV'D BY: NW
ADDRESS: _____ HOME #: _____
WORK #: _____

COMPLAINT: 1348-1352 Teaneck Rd

GARBAGE IN the
back of stores

Entered in log (CHECK)

FINDINGS: Valid

ACTION TAKEN: Sent violation notice

SIGNED NW

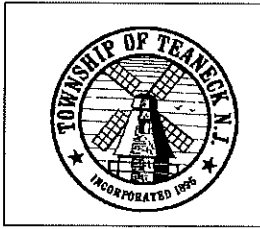

TEANECK HEALTH DEPARTMENT

818 TEANECK ROAD
TEANECK, NEW JERSEY 07666
(201) 837-1600

FO
5/16

NOTICE OF VIOLATION

Sent Certified and Regular Mail

Date:

Re: 23 Orchard Street, Teaneck, NJ 07666 (block 4905, lot 18)

Name: Jan London

Mailing Address: Same

05 / 04 / 18

Adopted

YOU ARE HEREBY NOTIFIED TO HAVE THE FOLLOWING CONDITION(S) REMEDIED WITHIN 15 DAYS.

Section(s):

Violation(s):

29A - 13, 23 xx Exterior is blighted, deteriorated, and/or inadequately maintained.

PLEASE REPLACE DAMAGED WOODEN FENCE LOCATED ON THE EAST SIDE OF YOUR PROPERTY (ADJACENT TO PARKING LOT).

RE-INSPECTION DATE ON OR AFTER: 05 / 16 / 18

IF YOU DESIRE A HEARING, YOU MUST CONTACT THE TEANECK HEALTH DEPT. WITHIN (5) DAYS. FAILURE TO COMPLY MAY RESULT IN ENFORCEMENT ACTIONS. EXTENSION REQUESTS MUST BE SUBMITTED TO ME IN WRITING. THIS ACTION IS NECESSARY AS A PUBLIC HEALTH MEASURE (201) 837-1600 Ext. 1508 OR NWONG@TEANECKNJ.GOV.

**Nelson O. Wong
Environmental Health Specialist
Teaneck Health Department**

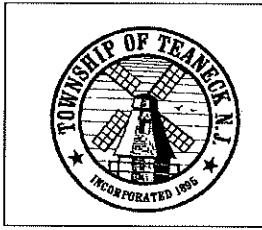

TEANECK HEALTH DEPARTMENT

818 TEANECK ROAD
TEANECK, NEW JERSEY 07666
(201) 837-1600

File

NOTICE OF VIOLATION

Sent Certified and Regular Mail

05 / 04 /18

Date:

Re: 23 Orchard Street, Teaneck, NJ 07666 (block 4905, lot 18)

Name: Jan London

Mailing Address: Same

**YOU ARE HEREBY NOTIFIED TO HAVE THE FOLLOWING CONDITION(S) REMEDIED
WITHIN 15 DAYS.**

Section(s):

Violation(s):

29A - 13, 23 xx Exterior is blighted, deteriorated, and/or inadequately maintained.

PLEASE REPLACE DAMAGED WOODEN FENCE LOCATED
ON THE EAST SIDE OF YOUR PROPERTY (ADJACENT TO
PARKING LOT).

RE-INSPECTION DATE ON OR AFTER: 05 / 16 /18

**IF YOU DESIRE A HEARING, YOU MUST CONTACT THE TEANECK HEALTH DEPT.
WITHIN (5) DAYS. FAILURE TO COMPLY MAY RESULT IN ENFORCEMENT ACTIONS.
EXTENSION REQUESTS MUST BE SUBMITTED TO ME IN WRITING.
THIS ACTION IS NECESSARY AS A PUBLIC HEALTH MEASURE (201) 837-1600 Ext. 1508
OR NWONG@TEANECKNJ.GOV.**

**Nelson O. Wong
Environmental Health Specialist
Teaneck Health Department**

Fwd: New Report It Notification

From: Ken Katter <kkatter@teanecknj.gov>

To: ccaviness@teanecknj.gov

Cc: fgarcia@teanecknj.gov, nwong@teanecknj.gov, tmereos@teanecknj.gov, KEN KATTER <kkatter@teanecknj.gov>, wbroughton@teanecknj.gov, dkazinci@teanecknj.gov

Date: 4/18/2018 2:00 PM

NW

CC

Please handle accordingly
Provide me with a copy of violation notice
Please update reportit app

Thanks

Sent from my iPhone

Begin forwarded message:

From: notification@reportit.com
Date: April 18, 2018 at 1:50:22 PM EDT
To: rgoodman@teanecknj.gov, health@teanecknj.gov
Subject: New Report It Notification

1352
1 ~~1348 Teaneck Rd~~
2 23 Orchard St
3 ~~20 W. Englewood Av~~

*Wooden Fence
IN disrepair*

Valid

ReportIt

New Report it Notification

A report has been submitted to Report it.

Short report:

Nature of Issue or Concern: Property Maintenance

I am Reporting As: Other - I'd rather not say

Location Of Incident: Teaneck Rd, Teaneck

Location Coordinates: 40.8981176379081, -74.0003678028719 Map

Comment: 1348 Teaneck Road Building Building In right side and Rear requires Painting and in Violation Of Township Codes This Entire Building And neighboring ones need Review for Multiple visable Violations Rusting vent pipe about to break and collapse at Rear Also And Parking Lot in Rear requires paving and Lot not striped for parking as required and arrow detailing directions not on pavement as required to code. Debris In Rear Of. Building including containers requires removal and fence Broken needs repair missing parts fence broken in rear lot and missing parts same for Adjoining neighbors.

To view this report in the Report Management Dashboard use this link:

[New Search](#) [Assessment Postcard](#) [Property Card](#)

| | | | |
|-------------|-------------------------|------------------------------|------------------|
| Block: 4905 | Prop Loc: 23 ORCHARD ST | Owner: LONDON,JAN | Square Ft: 1404 |
| Lot: 18 | District: 0260 TEANECK | Street: 23 ORCHARD ST | Year Built: 1911 |
| Qual: | Class: 2 | City State: TEANECK NJ 07666 | Style: SC |

Additional Information

| | | | |
|-------------------|------------------|------------------------|---------------------------------|
| Prior Block: | Acct Num: 045411 | Add Lots: | EPL Code: 0 0 0 |
| Prior Lot: | Mtg Acct: | Land Desc: 49X158 | Statute: |
| Prior Qual: | Bank Code: 0 | Bldg Desc: 2S-AL-O-1UG | Initial: 000000 Further: 000000 |
| Updated: 11/04/14 | Tax Codes: | Class4Cd: 0 | Desc: |
| Zone: BR | Map Page: | Acreage: 0.1777 | Taxes: 9337.85 / 0.00 |

Sale Date: 08/08/85 Book: 6946 Page: 61 Price: 113000 NU#: 0

| | | | | | | | |
|------|------|------|------|-------|-----|-------|---------|
| Srta | Date | Book | Page | Price | NU# | Ratio | Grantee |
|------|------|------|------|-------|-----|-------|---------|

TAX-LIST-HISTORY

| Year | Owner Information | Land/Imp/Tot | Exemption | Assessed | Property Class |
|-------------|---|----------------------------|-----------|----------|----------------|
| <u>2018</u> | LONDON,JAN 23 ORCHARD ST TEANECK NJ 07666 | 192900 104200 297100 | 0 | 297100 | 2 |
| <u>2017</u> | LONDON,JAN 23 ORCHARD ST TEANECK NJ 07666 | 192900 104200 297100 | 0 | 297100 | 2 |
| <u>2016</u> | LONDON,JAN 23 ORCHARD ST TEANECK NJ 07666 | 192900 104200 297100 | 0 | 297100 | 2 |
| <u>2015</u> | LONDON,JAN 23 ORCHARD ST TEANECK NJ 07666 | 192900 104200 297100 | 0 | 297100 | 2 |

*Click on Underlined Year for Tax List Page

[*Click Here for More History](#)

Appendix C:

Municipal Records: Police Department



Teaneck Police Department

900 Teaneck Rd, Teaneck, NJ 07666

Phone: 201-837-2600 Fax: 201-837-1880 Mun. Code: 0260

CAD Report



| Incident Details: | | | Incident Location: | | Disposition | | |
|--------------------------|---------|-----------------|-------------------------------|--------------|------------------|--------------|---------|
| Case Number | Time | Date | Address | | Disposition | | |
| PD-18-001556 | 00:38 | 01/12/18 | 61 GRAHAM PL, TEANECK TWP, NJ | | Report Completed | | |
| Incident Type: | | | Dispatched By | | Created By | | |
| Dom Viol Involv/ Assault | | | Ndeca | | Abull | | |
| Unit | Officer | Unit | Officer | Unit | Officer | Unit | Officer |
| 346 | Drueg | 336 | Jlync | 349 | Kflor | 340 | Jmeyer |
| Time Received | | Time Dispatched | | Time Arrived | | Time Cleared | |
| 0038 | | 0039 | | 0041 | | 0139 | |

| Contact Information: | | | | | | | |
|----------------------|--------------|---------|------|-------|-----|-------|-----|
| Role | Contact Name | Address | City | State | Zip | Phone | Fax |
| [REDACTED] | | | | | | | |

| Auto Information: | | | | | | | |
|-------------------|-------|------|-------|-------|------|-----|--|
| Registration | State | Make | Model | Color | Year | VIN | |
| | | | | | | | |

| Summonses: | | | | | |
|---------------|------|-----------|------|---------|--|
| Ticket Number | Date | Violation | Name | Officer | |
| | | | | | |

Narrative:
 Input ndeca 01 12 2018 00 39 07 Edited ndeca 01 12 2018 00 39 07 INTOXICATED MALE PARTY PUSHED A PREGNANT FEMALE Input ndeca 01 12 2018 00 39 21 Edited ndeca 01 12 2018 00 39 21 8033073345 Input ndeca 01 12 2018 00 40 12 Edited ndeca 01 12 2018 00 40 12 UNSURE OF WHERE MALE PARTY IS IN THE HOUSE Input ndeca 01 12 2018 00 40 54 Edited ndeca 01 12 2018 00 42 25 CALLER IS ABOVE RESIDENCE AND IS HEARING DISTURBANCE DOWN STAIRS Input ndeca 01 12 2018 00 41 28 Edited ndeca 01 12 2018 00 41 28 SCOTT BOLDIN Input ndeca 01 12 2018 00 41 48 Edited ndeca 01 12 2018 00 41 48 CALLER MELODY MENIFELD Input abull 01 12 2018 00 48 46 Edited abull 01 12 2018 00 49 06 1 MALE PARTY 10-66 FOR 10-83 AND OBSTRUCTION Input ndeca 01 12 2018 01 11 49 Edited ndeca 01 12 2018 01 11 49 B62242438206682 Input abull 01 12 2018 01 15 57 Edited abull 01 12 2018 01 15 57 ACTIVE 10-91 NCIC - CHILD SUPPORT Input abull 01 12 2018 01 22 12 Edited abull 01 12 2018 01 22 47 349 TRANSPORTING 1 MALE PARTY TO HQ 10-66 VEH 19 S M 15070 346 FOLLOWING Input abull 01 12 2018 01 25 02 Edited abull 01 12 2018 01 25 02 349 E



Teaneck Police Department

900 Teaneck Rd, Teaneck, NJ 07666

Phone: 201-837-2600 Fax: 201-837-1880 Mun. Code: 0260



Incident Report

| Incident Details: | | | Incident Location: | Disposition |
|--------------------------|-------|----------|-------------------------------|------------------|
| Case Number | Time | Date | Address | Disposition |
| PD-18-001556 | 00:38 | 01/12/18 | 61 GRAHAM PL, TEANECK TWP, NJ | Report Completed |
| Incident Type: | | | | |
| Dom Viol Involv/ Assault | | | | |
| Narrative | | Officer | Approving Officer | |
| | | jlynch | rharv | |

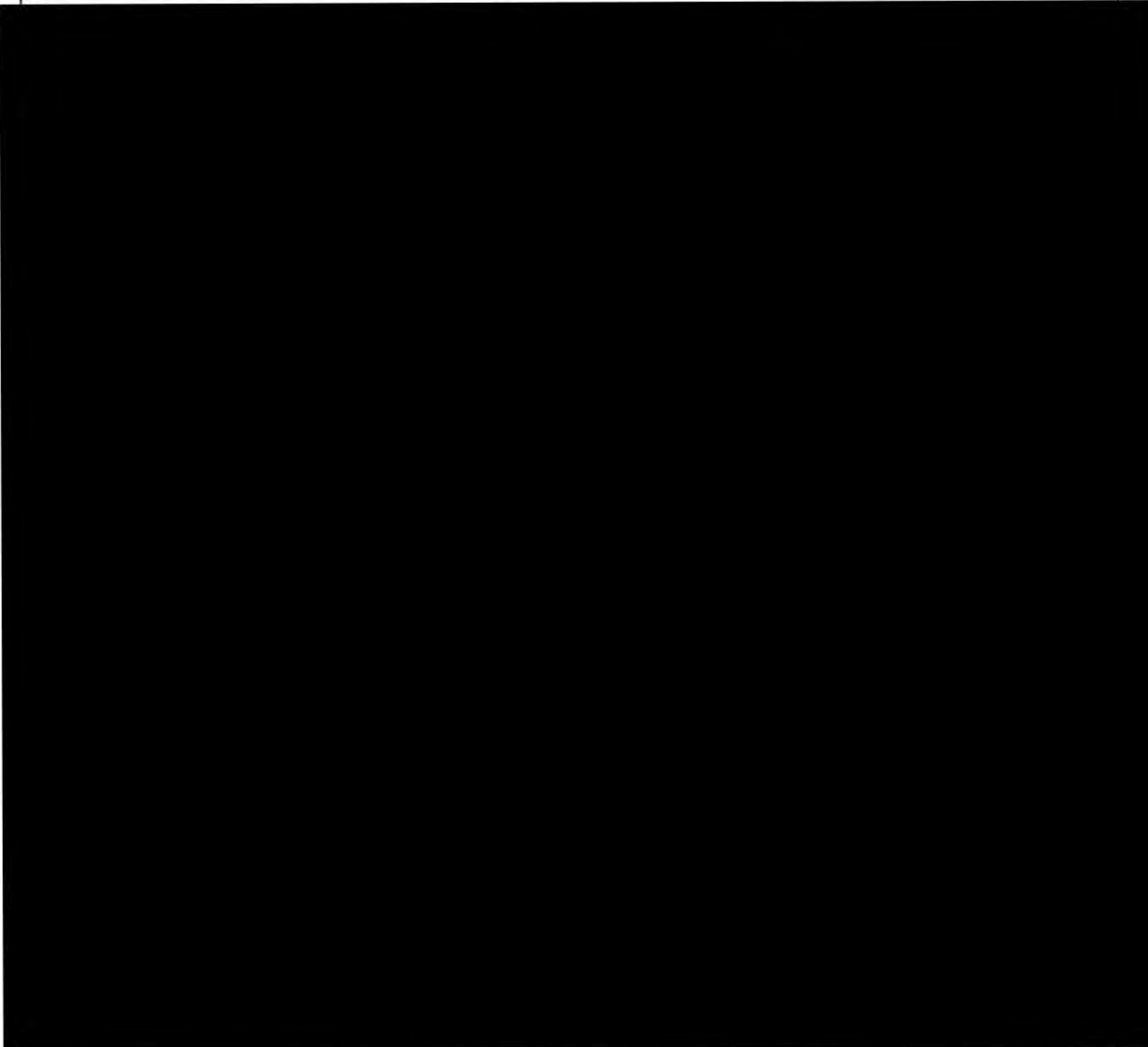



Teaneck Police Department

900 Teaneck Rd, Teaneck, NJ 07666

Phone: 201-837-2600 Fax: 201-837-1880 Mun. Code: 0260



Incident Report

| Incident Details: | | | Incident Location: | Disposition |
|--------------------------|-------|----------|-------------------------------|------------------|
| Case Number | Time | Date | Address | Disposition |
| PD-18-001556 | 00:38 | 01/12/18 | 61 GRAHAM PL, TEANECK TWP, NJ | Report Completed |
| Incident Type: | | | | |
| Dom Viol Involv/ Assault | | | | |
| Narrative | | Officer | Approving Officer | |
| | | drueg | rharv | |

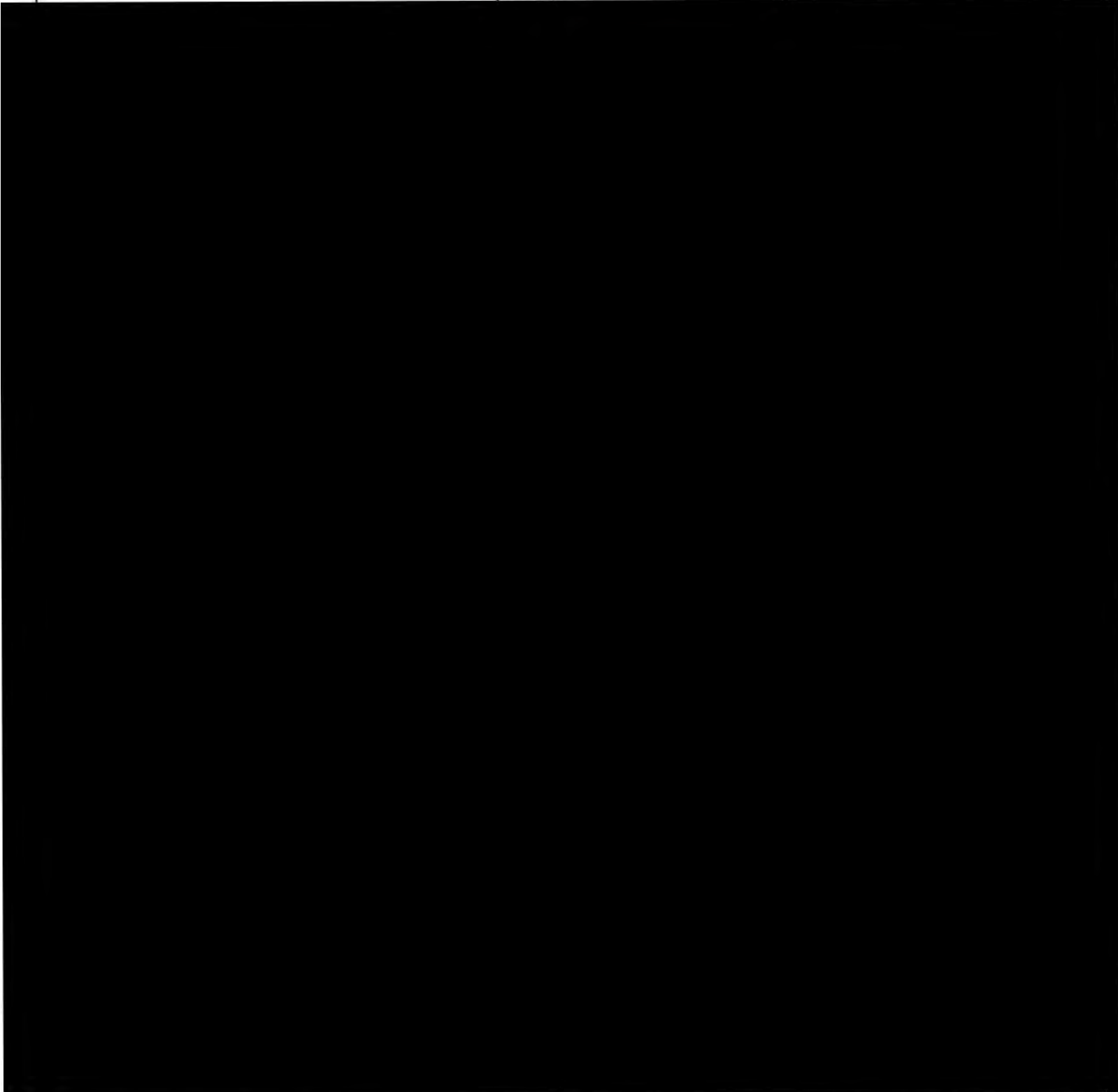



Teaneck Police Department

900 Teaneck Rd, Teaneck, NJ 07666

Phone: 201-837-2600 Fax: 201-837-1880 Mun. Code: 0260

Incident Report



Incident Details:

| Case Number | Time Reported | Date Reported | Time Occurred | Date Occurred | Occurrence Between Date / Time of | Time Occurred | Date Occurred | 911 | Completed |
|-------------|---------------|---------------|---------------|---------------|-----------------------------------|---------------|---------------|-----|-----------|
| 18-062086 | 22:53 | 12/15/18 | 22:53 | 12/15/18 | | | | X | X |

Incident Type:

Weapons/Unlawful Purposes 2C:39-4
 Assault
 Domestic Violence 2C:25-21

Incident Location:

Street # Street Name Intersection / Cross Street of:
 61 Graham Pl Graham Pl / Mersereau Ter
 Business / Common Location Name

Contact Information: Victim Suspect Complainant Witness Driver Arrest Passenger Missing Involved Other

Property Information:

| Value of Stolen Property | Currency | Jewelry | Furs | Clothing | Auto | Misc. | Total |
|------------------------------------|----------|---------|------|----------|------|-------|-------|
| | | | | | | | |
| Value of Stolen Property Recovered | | | | | | | |

Automobile Information:

| 1 | Vehicle Code | Year | Make | Body Type | Model | Color | Registration | State | VIN |
|---|--------------|------|------|-----------|-------|-------|--------------|-------|-----|
| 2 | | | | | | | | | |
| 3 | | | | | | | | | |
| 4 | | | | | | | | | |

Narrative:

Officer of Record: PO Stephen Morena 338 **Date:** 12/15/18 **Other Reports Filed:** MVA Arrest 1 DV 1 DWI DWIQ Tow SD CI TRO **Reviewed By:** jwilliams

| | |
|---|--|
| SHA Prop. Video UOF Prst Supp 1 Juv Bias Pris 1 | |
|---|--|



Teaneck Police Department

900 Teaneck Rd, Teaneck, NJ 07666

Phone: 201-837-2600 Fax: 201-837-1880 Mun. Code: 0260

Incident Report



Narrative Continued (Page 2)

Case Number

18-062086

Officer of Record:

Date:

PO Stephen Morena 338

12/15/18



Teaneck Police Department

900 Teaneck Rd, Teaneck, NJ 07666

Phone: 201-837-2600 Fax: 201-837-1880 Mun. Code: 0260

Incident Report



Narrative Continued (Page 3)

Case Number

18-062086

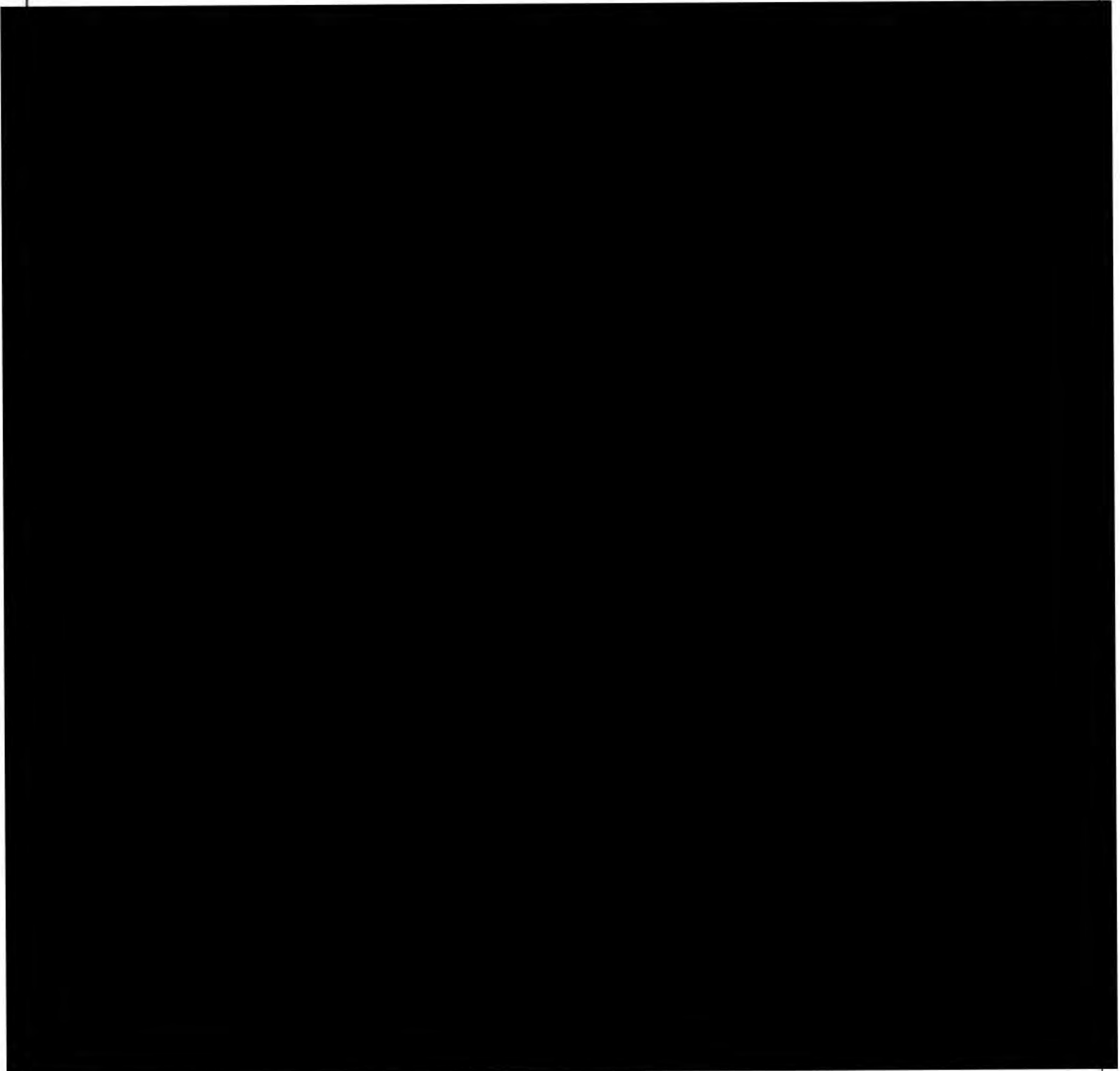

Officer of Record:

Date:

PO Stephen Morena 338

12/15/18



Teaneck Police Department

900 Teaneck Rd, Teaneck, NJ 07666

Phone: 201-837-2600 Fax: 201-837-1880 Mun. Code: 0260

Incident Report



Narrative Continued (Page 4)

Case Number

18-062086

Officer of Record:

Date:

PO Stephen Morena 338

12/15/18



Teaneck Police Department

900 Teaneck Rd, Teaneck, NJ 07666

Phone: 201-837-2600 Fax: 201-837-1880 Mun. Code: 0260

Incident Report - Additional Contacts



Incident Details:

| | | | | | | | | | |
|-------------|---------------|---------------|---------------|---------------|-----------------------------------|---------------|---------------|-----|-----------|
| Case Number | Time Reported | Date Reported | Time Occurred | Date Occurred | Occurrence Between Date / Time of | Time Occurred | Date Occurred | 911 | Completed |
| 18-062086 | 22:53 | 12/15/18 | 22:53 | 12/15/18 | | | | X | X |

| | | | | |
|-----------------------------------|--|---------------------------------|-------------|---------------------------------|
| Incident Type: | | Incident Location: | | |
| Weapons/Unlawful Purposes 2C:39-4 | | Street # | Street Name | Intersection / Cross Street of: |
| Assault | | 61 | Graham Pl | Graham Pl / Mersereau |
| Domestic Violence 2C:25-21 | | Business / Common Location Name | | |

Contact Information: Victim Suspect Complainant Witness Driver Arrest Passenger Missing Business Other

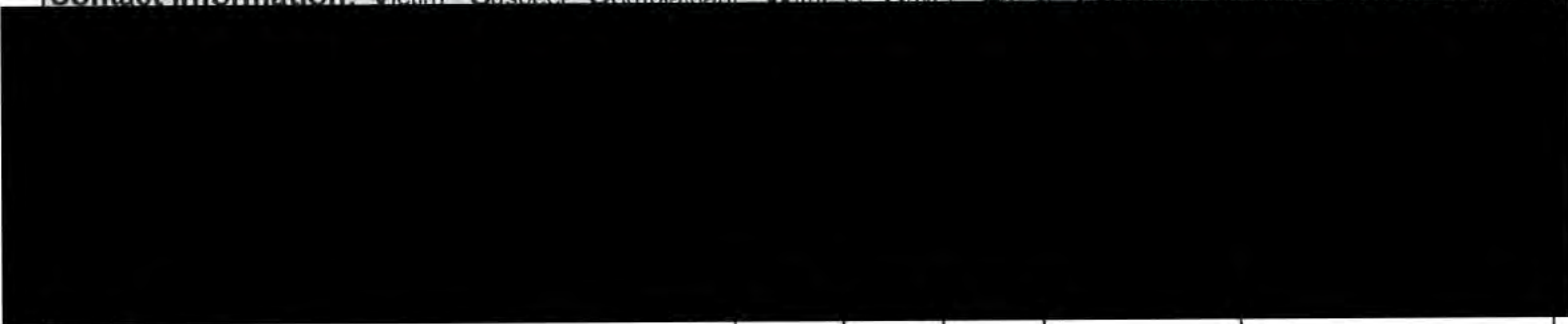

| | | | | | | | | |
|---------|----------------|------------|--------|------------|-----|------|-----|-----|
| Address | | Home Phone | | Cell Phone | | | | |
| Code | Contact Name # | MI | Suffix | Age | Sex | Race | DOB | SSN |
| Address | | Home Phone | | Cell Phone | | | | |

| Officer of | Date | Other Reports Filed: | | | | | | | Reviewed | | | | |
|-----------------------|----------|----------------------|--------|------|-----|------|------|------|----------|------|------|-----|--------|
| PO Stephen Morena 338 | 12/15/18 | MVA <T | Arrest | X | DV | X | DWI | DWIQ | Tow | SD | CI | TRO | |
| | | SHA | Prop | Evdn | UOF | Prst | Supp | X | Juv | Bias | Pris | X | JWILLI |



Teaneck Police Department

900 Teaneck Rd, Teaneck, NJ 07666

Phone: 201-837-2600 Fax: 201-837-1880 Mun. Code: 0260

Incident Report



| Incident Details: | | | | | | | | | |
|-------------------|---------------|---------------|---------------|---------------|-----------------------------------|---------------|---------------|-----|-----------|
| Case Number | Time Reported | Date Reported | Time Occurred | Date Occurred | Occurrence Between Date / Time of | Time Occurred | Date Occurred | 911 | Completed |
| 19-014512 | 14:22 | 03/15/19 | 14:22 | 03/15/19 | | | | X | X |

| Incident Type: | | Incident Location: | | |
|-------------------|--|---------------------------------|-------------|---------------------------------|
| Medical Emergency | | Street # | Street Name | Intersection / Cross Street of: |
| | | 61 | Graham Pl | Graham Pl / Mersereau Ter |
| | | Business / Common Location Name | | |

Contact Information: Victim Suspect Complainant Witness Driver Arrest Passenger Missing Involved Other

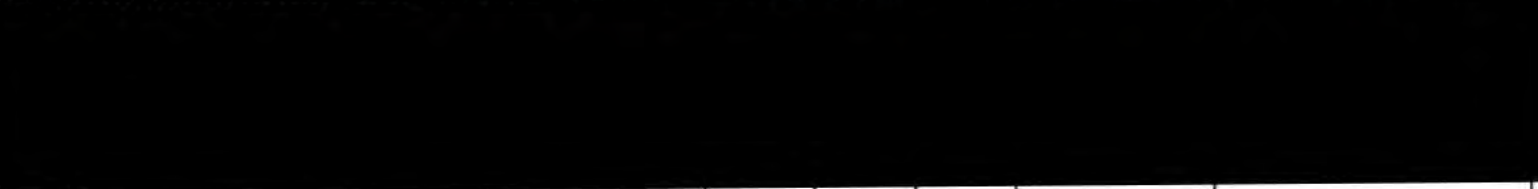

| | | | | | | | | | |
|---------|-----------------|----|--------|-----|-----|------------|-----|------------|--|
| Address | | | | | | Home Phone | | Cell Phone | |
| Code | Contact Name #3 | MI | Suffix | Age | Sex | Race | DOB | SSN | |
| Address | | | | | | Home Phone | | Cell Phone | |
| Code | Contact Name #4 | MI | Suffix | Age | Sex | Race | DOB | SSN | |
| Address | | | | | | Home Phone | | Cell Phone | |

| Property Information: | | | | | | | |
|------------------------------------|----------|---------|------|----------|------|-------|-------|
| Value of Stolen Property | Currency | Jewelry | Furs | Clothing | Auto | Misc. | Total |
| Value of Stolen Property Recovered | | | | | | | |

| Automobile Information: | | | | | | | | | |
|-------------------------|--------------|------|------|-----------|-------|-------|--------------|-------|-----|
| 1 | Vehicle Code | Year | Make | Body Type | Model | Color | Registration | State | VIN |
| 2 | | | | | | | | | |
| 3 | | | | | | | | | |
| 4 | | | | | | | | | |

Narrative:
 Party having difficulty breathing. Transported by TVAC to Holy Name Hospital.

| | | | | | | | | | | | |
|---------------------------|--------------|-----------------------------|--------|-------|-----|------|------|-----|------|---------------------|----------|
| Officer of Record: | Date: | Other Reports Filed: | | | | | | | | Reviewed By: | |
| PO Kevin Florio 349 | 03/15/19 | MVA | Arrest | DV | DWI | DWIQ | Tow | SD | CI | TRO | rmehnert |
| | | SHA | Prop. | Video | UOF | Prst | Supp | Juv | Bias | Pris | |



Teaneck Police Department

900 Teaneck Rd, Teaneck, NJ 07666

Phone: 201-837-2600 Fax: 201-837-1880 Mun. Code: 0260

Incident Report



Incident Details:

| | | | | | | | | | |
|-------------|---------------|---------------|---------------|---------------|-----------------------------------|---------------|---------------|-----|-----------|
| Case Number | Time Reported | Date Reported | Time Occurred | Date Occurred | Occurrence Between Date / Time of | Time Occurred | Date Occurred | 911 | Completed |
| 19-015677 | 13:22 | 03/21/19 | 22:45 | 03/15/19 | | 02:30 | 03/15/19 | | X |

| | | | | | | | | | | |
|-----------------------|--|--|---------------------------------|-------------|--|--|---------------------------------|--|--|--|
| Incident Type: | | | Incident Location: | | | | | | | |
| Lost Property | | | Street # | Street Name | | | Intersection / Cross Street of: | | | |
| | | | 61 | Graham Pl | | | Graham Pl / Mersereau Ter | | | |
| | | | Business / Common Location Name | | | | | | | |

Contact Information: Victim Suspect Complainant Witness Driver Arrest Passenger Missing Involved Other

| | | | | | | | | | |
|------------|--|--|--|--|--|--|--|--|--|
| [Redacted] | | | | | | | | | |
|------------|--|--|--|--|--|--|--|--|--|

| | | | | | | | | | | |
|---------|-----------------|--|--|----|--------|------------|-----|------------|-----|-----|
| Address | | | | | | Home Phone | | Cell Phone | | |
| Code | Contact Name #3 | | | MI | Suffix | Age | Sex | Race | DOB | SSN |
| Address | | | | | | Home Phone | | Cell Phone | | |
| Code | Contact Name #4 | | | MI | Suffix | Age | Sex | Race | DOB | SSN |
| Address | | | | | | Home Phone | | Cell Phone | | |

Property Information:

| | | | | | | | |
|------------------------------------|----------|---------|------|----------|------|-------|-------|
| Value of Stolen Property | Currency | Jewelry | Furs | Clothing | Auto | Misc. | Total |
| Value of Stolen Property Recovered | | | | | | | |

Automobile Information:

| 1 | Vehicle Code | Year | Make | Body Type | Model | Color | Registration | State | VIN |
|---|--------------|------|------|-----------|-------|-------|--------------|-------|-----|
| 2 | | | | | | | | | |
| 3 | | | | | | | | | |
| 4 | | | | | | | | | |

Narrative:

On Thursday, March 21, 2019 at approximately 1:22 PM [Redacted] responded to police headquarters to report that she had lost her passport.

[Redacted] reported that on Friday, March 15, 2019, around 10:45 PM, she responded to 46 Lounge in Totowa (300 US-46, Totowa, NJ 07512) to celebrate her birthday. While there she lost her passport in the bathroom. She left the lounge at approximately 2:30 AM the next morning [Redacted] has contacted the Lounge and they stated that they have not located the passport. [Redacted] has contacted the U.S. Department of State and completed a, Statement Regarding A Lost or Stolen U.S. Passport Book And/OR Card Form. A copy of this form was attached to this report.

Officer of Record: Date: Other Reports Filed: Reviewed By:

| | | | |
|----------------------|----------|---|----------|
| PO Dmitri Rueger 346 | 03/21/19 | MVA Arrest DV DWI DWIQ Tow SD CI TRO SHA Prop. Video UOF Prst Supp Juv Bias Pris | rmehnert |
|----------------------|----------|---|----------|



Teaneck Police Department

900 Teaneck Rd, Teaneck, NJ 07666

Phone: 201-837-2600 Fax: 201-837-1880 Mun. Code: 0260

Incident Report



Narrative Continued (Page 2)

Case Number

19-015677

A copy of this report was e-mailed to the BCPO Intelligence and Counterterrorism Unit (ICTU) in accordance with their notification protocol.

Officer of Record:

Date:

PO Dmitri Rueger 346

03/21/19



Teaneck Police Department

900 Teaneck Rd, Teaneck, NJ 07666

Phone: 201-837-2600 Fax: 201-837-1880 Mun. Code: 0260

Incident Report



| Incident Details: | | | | | | | | | |
|-------------------|---------------|---------------|---------------|---------------|-----------------------------------|---------------|---------------|-----|-----------|
| Case Number | Time Reported | Date Reported | Time Occurred | Date Occurred | Occurrence Between Date / Time of | Time Occurred | Date Occurred | 911 | Completed |
| 20-011769 | 20:13 | 02/25/20 | 20:13 | 02/25/20 | | | | X | X |

| Incident Type: | Incident Location: |
|---|---|
| Domestic Violence 2C:25-21 Harassment 2C:33-4 Disturbance / Noise Complaint | Street # Street Name 61 Graham PI Intersection / Cross Street of: Graham PI / Mersereau Ter Business / Common Location Name |

Contact Information: Victim, Suspect, Complainant, Witness, Driver, Arrest, Release, Missing, Lost, Other



| Property Information: | | | | | | | |
|------------------------------------|----------|---------|------|----------|------|-------|-------|
| Value of Stolen Property | Currency | Jewelry | Furs | Clothing | Auto | Misc. | Total |
| Value of Stolen Property Recovered | | | | | | | |

| Automobile Information: | | | | | | | | | |
|-------------------------|--------------|------|------|-----------|-------|-------|--------------|-------|-----|
| | Vehicle Code | Year | Make | Body Type | Model | Color | Registration | State | VIN |
| 1 | | | | | | | | | |
| 2 | | | | | | | | | |
| 3 | | | | | | | | | |
| 4 | | | | | | | | | |

Narrative:



| Officer of Record: | Date: | Other Reports Filed: | Reviewed By: |
|--------------------------|----------|---|--------------|
| PO Victoria Andino-Doran | 02/25/20 | MVA Arrest DV 1 DWI DWIQ Tow SD CI TRO SHA Prop. Video UOF Prst Supp 1 Juv Bias Pris | ddalessio |



Teaneck Police Department

900 Teaneck Rd, Teaneck, NJ 07666

Phone: 201-837-2600 Fax: 201-837-1880 Mun. Code: 0260

Incident Report



Narrative Continued (Page 2)

Case Number

20-011769

Officer of Record:

Date:

PO Victoria Andino-Doran 345

02/25/20



Teaneck Police Department

900 Teaneck Rd, Teaneck, NJ 07666

Phone: 201-837-2600 Fax: 201-837-1880 Mun. Code: 0260

Incident Report



| Incident Details: | | | | | | | | | |
|-------------------|---------------|---------------|---------------|---------------|-----------------------------------|---------------|---------------|-----|-----------|
| Case Number | Time Reported | Date Reported | Time Occurred | Date Occurred | Occurrence Between Date / Time of | Time Occurred | Date Occurred | 911 | Completed |
| 21-032523 | 07:08 | 06/20/21 | 07:08 | 06/20/21 | | | | X | X |

| Incident Type: | | | Incident Location: | | |
|--------------------|--|--|---------------------------------|---------------|---------------------------------|
| Unsecured Building | | | Street # | Street Name | Intersection / Cross Street of: |
| | | | 1347 | Mersereau Ter | Mersereau Ter / Graham Pl |
| | | | Business / Common Location Name | | |

| Contact Information: Victim Suspect Complainant Witness Driver Arrest Passenger Missing Involved Other | | | | | | | | | |
|--|-----------------|----|--------|-----|-----|------------|-----|------------|--|
| Code | Contact Name #1 | MI | Suffix | Age | Sex | Race | DOB | SSN | |
| Address | | | | | | Home Phone | | Cell Phone | |
| Code | Contact Name #2 | MI | Suffix | Age | Sex | Race | DOB | SSN | |
| Address | | | | | | Home Phone | | Cell Phone | |
| Code | Contact Name #3 | MI | Suffix | Age | Sex | Race | DOB | SSN | |
| Address | | | | | | Home Phone | | Cell Phone | |
| Code | Contact Name #4 | MI | Suffix | Age | Sex | Race | DOB | SSN | |
| Address | | | | | | Home Phone | | Cell Phone | |

| Property Information: | | | | | | | |
|------------------------------------|----------|---------|------|----------|------|-------|-------|
| Value of Stolen Property | Currency | Jewelry | Furs | Clothing | Auto | Misc. | Total |
| Value of Stolen Property Recovered | | | | | | | |

| Automobile Information: | | | | | | | | | |
|-------------------------|--------------|------|------|-----------|-------|-------|--------------|-------|-----|
| 1 | Vehicle Code | Year | Make | Body Type | Model | Color | Registration | State | VIN |
| 2 | | | | | | | | | |
| 3 | | | | | | | | | |
| 4 | | | | | | | | | |

Narrative:
 On Sunday, June 20, 2021 at approximately 7:08 a.m. Officer Melissa Terpstra #365 and I responded to 1347 Mersereau Terrace on a report of an unsecured door.
 Upon arrival I observed the front door to 1347 Mersereau Terrace opened. Officer Terpstra and I conducted in interior and exterior search and determined the residence to be unoccupied. There were negative signed of force entry or vandalism. Upon completion of the search the front was secured.

| Officer of Record: | Date: | Other Reports Filed: | Reviewed By: |
|------------------------|----------|---|--------------|
| PO Rafael Vallejos 362 | 06/20/21 | MVA Arrest DV DWI DWIQ Tow SD CI TRO SHA Prop. Video UOF Prst Supp Juv Bias Pris | ddalessio |



Teaneck Police Department

900 Teaneck Rd, Teaneck, NJ 07666

Phone: 201-837-2600 Fax: 201-837-1880 Mun. Code: 0260

Incident Report



Incident Details:

| | | | | | | | | | |
|-------------|---------------|---------------|---------------|---------------|-----------------------------------|---------------|---------------|-----|-----------|
| Case Number | Time Reported | Date Reported | Time Occurred | Date Occurred | Occurrence Between Date / Time of | Time Occurred | Date Occurred | 911 | Completed |
| 21-063221 | 14:32 | 11/14/21 | 14:32 | 11/14/21 | | | | | X |

Incident Type:

Animal Incident - Domestic

Incident Location:

| | | |
|---------------------------------|-----------------|---------------------------------|
| Street # | Street Name | Intersection / Cross Street of: |
| 44 | W Englewood Ave | W Englewood Ave / |
| Business / Common Location Name | | |

Property Information:

| | | | | | | | |
|------------------------------------|----------|---------|------|----------|------|-------|-------|
| Value of Stolen Property | Currency | Jewelry | Furs | Clothing | Auto | Misc. | Total |
| Value of Stolen Property Recovered | | | | | | | |

Automobile Information:

| | Vehicle Code | Year | Make | Body Type | Model | Color | Registration | State | VIN |
|---|--------------|------|------|-----------|-------|-------|--------------|-------|-----|
| 1 | | | | | | | | | |
| 2 | | | | | | | | | |
| 3 | | | | | | | | | |
| 4 | | | | | | | | | |

Narrative:

On Sunday, November 14, 2021, at approximately 2:32 P.M., P.O. P. West #299 and I responded to 44 West Englewood Avenue, on a report of two children being bite by a dog.

Officer of Record:

Date:

Other Reports Filed:

Reviewed By:

| | | | | | | | | | | | |
|-----------------------|----------|-----|--------|-------|-----|------|------|-----|------|------|--------|
| PO Daiana Jackson 369 | 11/14/21 | MVA | Arrest | DV | DWI | DWIQ | Tow | SD | CI | TRO | jhosey |
| | | SHA | Prop. | Video | UOF | Prst | Supp | Juv | Bias | Pris | |



Teaneck Police Department

900 Teaneck Rd, Teaneck, NJ 07666

Phone: 201-837-2600 Fax: 201-837-1880 Mun. Code: 0260

Incident Report



Narrative Continued (Page 2)

Case Number

21-063221

Upon arrival, I met with [REDACTED] who stated that they were in the backyard of 44 W Englewood for a family cookout. They stated that the kids were in the backyard throwing a plastic ball around. [REDACTED] stated that the ball went over the fence onto Graham Place, and the kids walked over to Graham Place to retrieve the ball. As they were walking back she observed a white and black Pitbull following them, back toward the residence. She stated that the kids walked into the backyard, and the dog followed. Ms. Hutson stated that the dog began walking up to the adults as they were sitting and began sniffing them. She stated that out of nowhere the dog ran over to the [REDACTED] as they were swinging on the swings, and began pulling them off of the swing set.

I then responded to 61 Graham Place to speak to the owner of the dog [REDACTED]. He stated that he was in the backyard of his home cleaning out the dog cage. He stated that he did not notice that his dog was loose until he heard kids crying and began looking for his dog. He stated that he immediately ran over to 44 W Englewood and gained control of his dog. [REDACTED] stated that his dog was not licensed.

A Teaneck Animal Bite form was completed, signed and faxed over to the Health department, for further investigation.

Officer of Record:

Date:

PO Daiana Jackson 369

11/14/21



Teaneck Police Department

900 Teaneck Rd, Teaneck, NJ 07666

Phone: 201-837-2600 Fax: 201-837-1880 Mun. Code: 0260



Incident Report - Additional Contacts

| Incident Details: | | | | | | | | | |
|-------------------|---------------|---------------|---------------|---------------|-----------------------------------|---------------|---------------|-----|-----------|
| Case Number | Time Reported | Date Reported | Time Occurred | Date Occurred | Occurrence Between Date / Time of | Time Occurred | Date Occurred | 911 | Completed |
| 21-063221 | 14:32 | 11/14/21 | 14:32 | 11/14/21 | | | | | X |

| Incident Type: | Incident Location: |
|----------------------------|--|
| Animal Incident - Domestic | Street # Street Name Intersection / Cross Street of: |
| | 44 W Englewood Ave W Englewood Ave / |
| | Business / Common Location Name |

Contact Information: Victim Suspect Complainant Witness Driver Arrest Passenger Missing Business Other



| | | | | | | | | | |
|---------|----------------|----|--------|-----|------------|------|-----|------------|--|
| Address | | | | | Home Phone | | | Cell Phone | |
| Code | Contact Name # | MI | Suffix | Age | Sex | Race | DOB | SSN | |
| Address | | | | | Home Phone | | | Cell Phone | |

| Officer of | Date | Other Reports Filed: | | | | | | | | | | Reviewed |
|-----------------------|----------|----------------------|--------|------|-----|------|------|-----|------|------|--|----------|
| PO Daiana Jackson 369 | 11/14/21 | MVA <T | Arrest | DV | DWI | DWIQ | Tow | SD | CI | TRO | | JHOSE |
| | | SHA | Prop | Evdn | UOF | Prst | Supp | Juv | Bias | Pris | | |



Teaneck Police Department

900 Teaneck Rd, Teaneck, NJ 07666

Phone: 201-837-2600 Fax: 201-837-1880 Mun. Code: 0260

Incident Report



| Incident Details: | | | | | | | | | |
|-------------------|---------------|---------------|---------------|---------------|-----------------------------------|---------------|---------------|-----|-----------|
| Case Number | Time Reported | Date Reported | Time Occurred | Date Occurred | Occurrence Between Date / Time of | Time Occurred | Date Occurred | 911 | Completed |
| 22-028136 | 13:00 | 05/19/22 | 13:00 | 05/19/22 | | | | X | X |

| Incident Type: | Incident Location: |
|-------------------|---|
| Medical Emergency | Street # Street Name 44 W Englewood Ave Intersection / Cross Street of: W Englewood Ave / Business / Common Location Name |

Contact Information: Victim Suspect Complainant Witness Driver Arrest Passenger Missing Involved Other

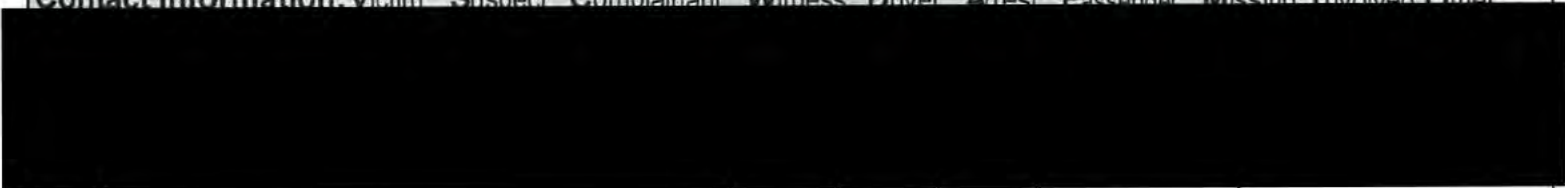

| | | | | | | | | | |
|---------|-----------------|----|--------|-----|-----|------------|-----|------------|--|
| Address | | | | | | Home Phone | | Cell Phone | |
| Code | Contact Name #3 | MI | Suffix | Age | Sex | Race | DOB | SSN | |
| Address | | | | | | Home Phone | | Cell Phone | |
| Code | Contact Name #4 | MI | Suffix | Age | Sex | Race | DOB | SSN | |
| Address | | | | | | Home Phone | | Cell Phone | |

| Property Information: | | | | | | | |
|------------------------------------|----------|---------|------|----------|------|-------|-------|
| Value of Stolen Property | Currency | Jewelry | Furs | Clothing | Auto | Misc. | Total |
| Value of Stolen Property Recovered | | | | | | | |

| Automobile Information: | | | | | | | | | |
|-------------------------|--------------|------|------|-----------|-------|-------|--------------|-------|-----|
| 1 | Vehicle Code | Year | Make | Body Type | Model | Color | Registration | State | VIN |
| 2 | | | | | | | | | |
| 3 | | | | | | | | | |
| 4 | | | | | | | | | |

Narrative:
 On Thursday, May 19, 2022, at approximately 1:00 PM, I responded to 44 W. Englewood Avenue, on a report of a [REDACTED] I responded in motor patrol vehicle #18 in routine manner.
 Upon arrival, members of the Teaneck Volunteer Ambulance Corps. (TVAC) responded to assist. Patient was subsequently transported to Holy Name Medical Center (HNMC) for further medical evaluation.

| Officer of Record: | Date: | Other Reports Filed: | Reviewed By: |
|--------------------|----------|---|--------------|
| PO Kevin Gibbs 363 | 05/19/22 | MVA Arrest DV DWI DWIQ Tow SD CI TRO SHA Prop. Video UOF Prst Supp Juv Blas Pris | rboswell |



Teaneck Police Department

900 Teaneck Rd, Teaneck, NJ 07666

Phone: 201-837-2600 Fax: 201-837-1880 Mun. Code: 0260

CAD Report



| Incident Details: | | | Incident Location: | | Disposition |
|-------------------|-------|----------|-----------------------------|--|------------------|
| Case Number | Time | Date | Address | | Disposition |
| PD-17-047010 | 21:37 | 12/27/17 | 26 W ENGLEWOOD AVE, TEANECK | | Report Completed |

| Incident Type: | | | | Dispatched By | | Created By | |
|------------------------|---------|-----------------|---------|---------------|---------|--------------|---------|
| Obstruction Of Justice | | | | Abull | | Dkazm | |
| Unit | Officer | Unit | Officer | Unit | Officer | Unit | Officer |
| 336 | Jlync | 328 | Alohs | 349 | Kflor | | |
| Time Received | | Time Dispatched | | Time Arrived | | Time Cleared | |
| 2137 | | 2137 | | 2138 | | 2213 | |

| Contact Information: | | | | | | | | |
|----------------------|--------------|---------|--|--|-----|-----|------|-------|
| Role | Contact Name | Address | | | DOB | Sex | Race | Phone |
| | | | | | | | | |

| Auto Information: | | | | | | | |
|-------------------|-------|------|-------|-------|------|-----|--|
| Registration | State | Make | Model | Color | Year | VIN | |
| | | | | | | | |

| Summonses: | | | | | |
|---------------|------|-----------|------|---------|--|
| Ticket Number | Date | Violation | Name | Officer | |
| | | | | | |

Narrative:
 Input abull 12 27 2017 21 38 20 Edited abull 12 27 2017 21 38 20 SYLVIA 201 598 2022 REQUESTS HER DAUGHTERS BOYFRIEND [REDACTED] BE REMOVED FROM THE RESIDENCE. ISSUE HAS HAPPENED BEFORE.
 Input dkazm 12 27 2017 21 45 25 Edited dkazm 12 27 2017 21 45 25 [REDACTED] Input dkazm 12 27 2017 21 53 02 Edited dkazm 12 27 2017 21 53 02 PARTY SHOWING SEVERAL ACTIVE 91 S Input dkazm 12 27 2017 21 53 17 Edited dkazm 12 27 2017 21 53 17 NJ P35851678256982 Input dkazm 12 27 2017 21 53 51 Edited dkazm 12 27 2017 21 53 51 1 MALE 66 FOR OBSTRUCTION. Input abull 12 27 2017 21 54 51 Edited abull 12 27 2017 21 54 51 ZKE91P Input dkazm 12 27 2017 21 55 24 Edited dkazm 12 27 2017 21 55 24 NJ ZKE91P Input dkazm 12 27 2017 21 59 40 Edited dkazm 12 27 2017 21 59 40 336 349 TRANSPORTING 1 MALE 66 TO HQ IN CAR 18 S M 17532 328 FOLLOWING Input dkazm 12 27 2017 22 02 12 Edited dkazm 12 27 2017 22 02 40 E M 17538



Teaneck Police Department

900 Teaneck Rd, Teaneck, NJ 07666

Phone: 201-837-2600 Fax: 201-837-1880 Mun. Code: 0260



Incident Report

| Incident Details: | | | Incident Location: | Disposition |
|------------------------|-------|----------|-----------------------------|------------------|
| Case Number | Time | Date | Address | Disposition |
| PD-17-047010 | 21:37 | 12/27/17 | 26 W ENGLEWOOD AVE, TEANECK | Report Completed |
| Incident Type: | | | | |
| Obstruction Of Justice | | | | |
| Narrative | | Officer | Approving Officer | |
| | | jlynch | rharv | |

On Wednesday December 27 2017 at approximately 9 37 P.M. Officer Lohsen 328 Officer Lynch 336 and I were dispatched to the residence of 26 West Englewood Avenue on a report of an unwanted party



and his property were turned over to Hackensack Police Officer Katsaroans 326. Police Officer Kevin Florio 349.



Teaneck Police Department

900 Teaneck Rd, Teaneck, NJ 07666

Phone: 201-837-2600 Fax: 201-837-1880 Mun. Code: 0260

Incident Report



Incident Details:

| | | | | | | | | | |
|-------------|---------------|---------------|---------------|---------------|-----------------------------------|---------------|---------------|-----|-----------|
| Case Number | Time Reported | Date Reported | Time Occurred | Date Occurred | Occurrence Between Date / Time of | Time Occurred | Date Occurred | 911 | Completed |
| 18-055139 | 15:48 | 11/08/18 | 18:00 | 11/02/18 | | 08:00 | 11/06/18 | | X |

| | | | | | | | | | |
|-----------------------|--|--|---------------------------------|--|--|--|---------------------------------|--|--|
| Incident Type: | | | Incident Location: | | | | | | |
| Theft 2C:20-3 | | | Street # Street Name | | | | Intersection / Cross Street of: | | |
| | | | 26 W Englewood Ave | | | | W Englewood Ave / Teaneck | | |
| | | | Business / Common Location Name | | | | | | |

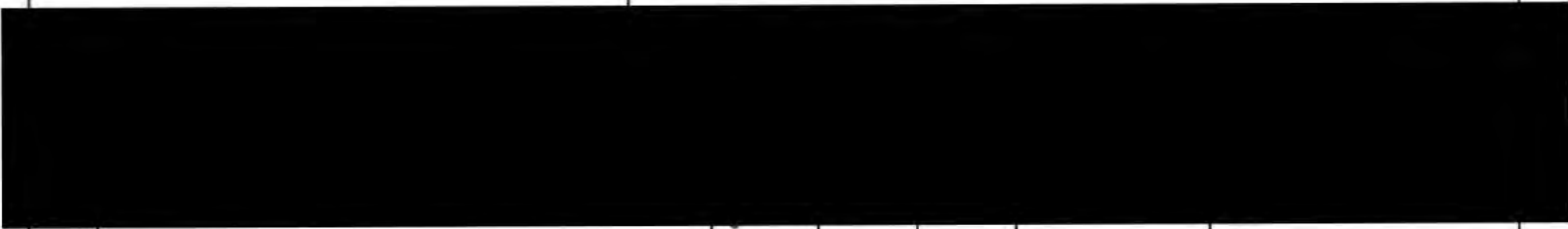

| | | | | | | | | | |
|---------|-----------------|----|--------|-----|-----|------------|-----|------------|--|
| Address | | | | | | Home Phone | | Cell Phone | |
| Code | Contact Name #3 | MI | Suffix | Age | Sex | Race | DOB | SSN | |
| Address | | | | | | Home Phone | | Cell Phone | |
| Code | Contact Name #4 | MI | Suffix | Age | Sex | Race | DOB | SSN | |
| Address | | | | | | Home Phone | | Cell Phone | |

Property Information:

| | | | | | | | |
|------------------------------------|----------|---------|------|----------|------|----------|----------|
| Value of Stolen Property | Currency | Jewelry | Furs | Clothing | Auto | Misc. | Total |
| | | | | | | \$550.00 | \$550.00 |
| Value of Stolen Property Recovered | | | | | | | |

Automobile Information:

| | Vehicle Code | Year | Make | Body Type | Model | Color | Registration | State | VIN |
|---|--------------|------|------|-----------|-------|-------|--------------|-------|-----|
| 1 | | | | | | | | | |
| 2 | | | | | | | | | |
| 3 | | | | | | | | | |
| 4 | | | | | | | | | |

Narrative:

On Thursday, November 8, 2018 at 1548 hrs [REDACTED] (the victim) walked into headquarters and filed a "Civilian Report" form stating that she was the victim of a theft.

The victim stated that sometime between 1800 hrs Friday, November 2, 2018 and 0800 hrs Monday, November 5, 2018 some unknown actor(s) took a "Red Max" brand backpack blower. The blower was secured/affixed to a landscape type low boy trailer. The trailer was parked in the rear yard of 26 West Englewood Ave Teaneck, NJ 07666.

The victim described the blower as red in color, with the wing nut on the air filter cover missing and

| | | | | | | | | | | | |
|---------------------------|--------------|-----------------------------|--------|-------|-----|------|------|----|-----|---------------------|-----------|
| Officer of Record: | Date: | Other Reports Filed: | | | | | | | | Reviewed By: | |
| PO Joseph Careccio | 232 11/08/18 | MVA | Arrest | DV | DWI | DWIQ | Tow | SD | CI | TRO | pforrest- |
| | | SHA | Prop. | Video | UOF | Prst | Supp | 1 | Juv | Bias | |



Teaneck Police Department

900 Teaneck Rd, Teaneck, NJ 07666

Phone: 201-837-2600 Fax: 201-837-1880 Mun. Code: 0260

Incident Report



Narrative Continued (Page 2)

Case Number

18-055139

brown and tan duct tape covering a hole on the blower tube.

The victim stated that the replacement cost of this item is approximately five hundred and fifty dollars (\$550.00), and that she does not have the serial number of this unit.

Officer of Record:

Date:

PO Joseph Careccio 232

11/08/18



Teaneck Police Department

900 Teaneck Rd, Teaneck, NJ 07666

Phone: 201-837-2600 Fax: 201-837-1880 Mun. Code: 0260

Incident Report



Incident Details:

| | | | | | | | | | |
|-------------|---------------|---------------|---------------|---------------|-----------------------------------|---------------|---------------|-----|-----------|
| Case Number | Time Reported | Date Reported | Time Occurred | Date Occurred | Occurrence Between Date / Time of | Time Occurred | Date Occurred | 911 | Completed |
| 20-000280 | 07:40 | 01/02/20 | 07:40 | 01/02/20 | | | | X | X |

Incident Type:

Medical Emergency

Incident Location:

Street # Street Name Intersection / Cross Street of:
 26 W Englewood Ave W Englewood Ave / Teaneck
 Business / Common Location Name

Contact Information: Victim Suspect Complainant Witness Driver Arrest Passenger Missing Involved Other

| | | | | | | | | |
|---------|-----------------|----|--------|-----|-----|------------|-----|------------|
| Code | Contact Name #2 | MI | Suffix | Age | Sex | Race | DOB | SSN |
| Address | | | | | | Home Phone | | Cell Phone |
| Code | Contact Name #3 | MI | Suffix | Age | Sex | Race | DOB | SSN |
| Address | | | | | | Home Phone | | Cell Phone |
| Code | Contact Name #4 | MI | Suffix | Age | Sex | Race | DOB | SSN |
| Address | | | | | | Home Phone | | Cell Phone |

Property Information:

| | | | | | | | |
|------------------------------------|----------|---------|------|----------|------|-------|-------|
| Value of Stolen Property | Currency | Jewelry | Furs | Clothing | Auto | Misc. | Total |
| Value of Stolen Property Recovered | | | | | | | |

Automobile Information:

| 1 | Vehicle Code | Year | Make | Body Type | Model | Color | Registration | State | VIN |
|---|--------------|------|------|-----------|-------|-------|--------------|-------|-----|
| 2 | | | | | | | | | |
| 3 | | | | | | | | | |
| 4 | | | | | | | | | |

Narrative:

1 to Holy Name Hospital.

Officer of Record:

Date:

Other Reports Filed:

Reviewed By:

| | | | | | | | | | | | |
|---------------------|----------|-----|--------|-------|-----|------|------|-----|------|------|--------|
| PO Zachary Reed 352 | 01/02/20 | MVA | Arrest | DV | DWI | DWIQ | Tow | SD | CI | TRO | ttully |
| | | SHA | Prop. | Video | UOF | Prst | Supp | Juv | Bias | Pris | |



Teaneck Police Department

900 Teaneck Rd, Teaneck, NJ 07666

Phone: 201-837-2600 Fax: 201-837-1880 Mun. Code: 0260

Incident Report



Incident Details:

| | | | | | | | | | |
|-------------|---------------|---------------|---------------|---------------|-----------------------------------|---------------|---------------|-----|-----------|
| Case Number | Time Reported | Date Reported | Time Occurred | Date Occurred | Occurrence Between Date / Time of | Time Occurred | Date Occurred | 911 | Completed |
| 20-063538 | 20:34 | 12/25/20 | 20:34 | 12/25/20 | | | | X | X |

Incident Type:

Medical Emergency

Incident Location:

| | | |
|---------------------------------|-----------------|---------------------------------|
| Street # | Street Name | Intersection / Cross Street of: |
| 26 | W Englewood Ave | W Englewood Ave / Teaneck |
| Business / Common Location Name | | |

| | | | | | | | | | |
|---------|-----------------|----|--------|-----|------------|------|-----|------------|--|
| Address | | | | | Home Phone | | | Cell Phone | |
| Code | Contact Name #4 | MI | Suffix | Age | Sex | Race | DOB | SSN | |
| Address | | | | | Home Phone | | | Cell Phone | |

Property Information:

| | | | | | | | |
|------------------------------------|----------|---------|------|----------|------|-------|-------|
| Value of Stolen Property | Currency | Jewelry | Furs | Clothing | Auto | Misc. | Total |
| Value of Stolen Property Recovered | | | | | | | |

Automobile Information:

| | Vehicle Code | Year | Make | Body Type | Model | Color | Registration | State | VIN |
|---|--------------|------|------|-----------|-------|-------|--------------|-------|-----|
| 1 | | | | | | | | | |
| 2 | | | | | | | | | |
| 3 | | | | | | | | | |
| 4 | | | | | | | | | |

Narrative:

On Friday December 25, 2020 at approximately 8:34pm, I responded with my emergency lights to 26 West Englewood Ave on a report of a young female choking.

Upon my arrival I was met by a [REDACTED] who stated that her daughter [REDACTED] choked on a candy cane. The candy cane was removed and [REDACTED] was breathing upon my arrival. Teaneck Volunteer Ambulance Corps arrived and evaluated [REDACTED] with no concerning issues [REDACTED] signed a RMA.

My Arbitrator 360 dash camera was activated.

| | | | |
|---------------------------|--------------|---|---------------------|
| Officer of Record: | Date: | Other Reports Filed: | Reviewed By: |
| PO Michael Spann 344 | 12/25/20 | MVA Arrest DV DWI DWIQ Tow SD CI TRO SHA Prop. Video UOF Prst Supp Juv Bias Pris | cantineri |



Teaneck Police Department

900 Teaneck Rd, Teaneck, NJ 07666

Phone: 201-837-2600 Fax: 201-837-1880 Mun. Code: 0260

Incident Report



Incident Details:

| | | | | | | | | | |
|-------------|---------------|---------------|---------------|---------------|-----------------------------------|---------------|---------------|-----|-----------|
| Case Number | Time Reported | Date Reported | Time Occurred | Date Occurred | Occurrence Between Date / Time of | Time Occurred | Date Occurred | 911 | Completed |
| 21-063129 | 00:14 | 11/14/21 | 00:14 | 11/14/21 | | | | X | X |

Incident Type:

Medical Emergency

Incident Location:

| | | |
|---------------------------------|-----------------|---------------------------------|
| Street # | Street Name | Intersection / Cross Street of: |
| 26 | W Englewood Ave | W Englewood Ave / Teaneck |
| Business / Common Location Name | | |

Contact Information: Victim Suspect Complainant Witness Driver Arrest Passenger Missing Involved Other



| | | | | | | | | | |
|---------|-----------------|----|--------|-----|-----|------------|-----|------------|--|
| Address | | | | | | Home Phone | | Cell Phone | |
| Code | Contact Name #3 | MI | Suffix | Age | Sex | Race | DOB | SSN | |
| Address | | | | | | Home Phone | | Cell Phone | |
| Code | Contact Name #4 | MI | Suffix | Age | Sex | Race | DOB | SSN | |
| Address | | | | | | Home Phone | | Cell Phone | |

Property Information:

| | | | | | | | |
|------------------------------------|----------|---------|------|----------|------|-------|-------|
| Value of Stolen Property | Currency | Jewelry | Furs | Clothing | Auto | Misc. | Total |
| Value of Stolen Property Recovered | | | | | | | |

Automobile Information:

| 1 | Vehicle Code | Year | Make | Body Type | Model | Color | Registration | State | VIN |
|---|--------------|------|------|-----------|-------|-------|--------------|-------|-----|
| 2 | | | | | | | | | |
| 3 | | | | | | | | | |
| 4 | | | | | | | | | |

Narrative:

On Sunday, November 14, 2021, at approximately 12:14 am, The Teaneck Volunteer Ambulance Corps (TVAC) and I responded to 26 West Englewood, on a report of a male party having difficulty breathing.

Upon arrival, the ambulance members met with [REDACTED]. They assessed him on scene and he refused further medical attention.

Submitted By: Wilbert Pena #372

| | | | | | | | | | | | | |
|---------------------------|--------------|-----------------------------|--------|-------|-----|------|------|-----|------|------|--|---------------------|
| Officer of Record: | Date: | Other Reports Filed: | | | | | | | | | | Reviewed By: |
| PO Wilbert Pena 372 | 11/14/21 | MVA | Arrest | DV | DWI | DWIQ | Tow | SD | CI | TRO | | jgarland |
| | | SHA | Prop. | Video | UOF | Prst | Supp | Juv | Bias | Pris | | |



Teaneck Police Department

900 Teaneck Rd, Teaneck, NJ 07666

Phone: 201-837-2600 Fax: 201-837-1880 Mun. Code: 0260

Incident Report



| Incident Details: | | | | | | | | | |
|-------------------|---------------|---------------|---------------|---------------|-----------------------------------|---------------|---------------|-----|-----------|
| Case Number | Time Reported | Date Reported | Time Occurred | Date Occurred | Occurrence Between Date / Time of | Time Occurred | Date Occurred | 911 | Completed |
| 21-063169 | 08:16 | 11/14/21 | 08:16 | 11/14/21 | | | | X | X |

| Incident Type: | | Incident Location: | |
|-------------------|--|--|-----------------|
| Medical Emergency | | Street # | Street Name |
| | | 26 | W Englewood Ave |
| | | Intersection / Cross Street of: W Englewood Ave / Teaneck | |
| | | Business / Common Location Name | |

Contact Information: Victim Suspect Complainant Witness Driver Arrest Recipient Missing Involved Other

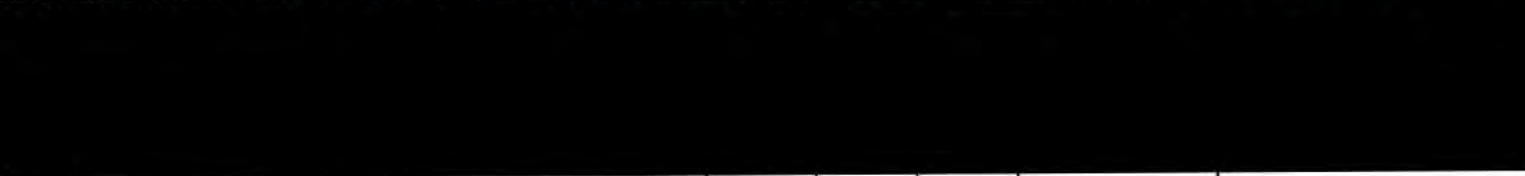

| | | | | | | | |
|---------|-----------------|------------|-----|------------|------|-----|-----|
| Address | | Home Phone | | Cell Phone | | | |
| Code | Contact Name #3 | MI Suffix | Age | Sex | Race | DOB | SSN |
| Address | | Home Phone | | Cell Phone | | | |
| Code | Contact Name #4 | MI Suffix | Age | Sex | Race | DOB | SSN |
| Address | | Home Phone | | Cell Phone | | | |

| Property Information: | | | | | | | |
|------------------------------------|----------|---------|------|----------|------|-------|-------|
| Value of Stolen Property | Currency | Jewelry | Furs | Clothing | Auto | Misc. | Total |
| Value of Stolen Property Recovered | | | | | | | |

| Automobile Information: | | | | | | | | | |
|-------------------------|--------------|------|------|-----------|-------|-------|--------------|-------|-----|
| 1 | Vehicle Code | Year | Make | Body Type | Model | Color | Registration | State | VIN |
| 2 | | | | | | | | | |
| 3 | | | | | | | | | |
| 4 | | | | | | | | | |

Narrative:
 On Sunday, November 14, 2021, at approximately 8:16 AM, I responded to 26 W. Englewood Avenue on a report of a nineteen (19) year old male, shaking and vomiting. I responded in motor patrol vehicle #10.
 Upon arrival, members of the Teaneck Volunteer Ambulance Corps. (TVAC) responded to assist. Patient was subsequently transported to Holy Name Medical Center (HNMC) for further medical evaluation.

| Officer of Record: | Date: | Other Reports Filed: | | | | | | | | | | Reviewed By: |
|--------------------|----------|----------------------|--------|-------|-----|------|------|-----|------|------|--|--------------|
| PO Kevin Gibbs 363 | 11/14/21 | MVA | Arrest | DV | DWI | DWIQ | Tow | SD | CI | TRO | | jhosey |
| | | SHA | Prop. | Video | UOF | Prst | Supp | Juv | Bias | Pris | | |



Teaneck Police Department

900 Teaneck Rd, Teaneck, NJ 07666

Phone: 201-837-2600 Fax: 201-837-1880 Mun. Code: 0260

Incident Report



Incident Details:

| | | | | | | | | | |
|-------------|---------------|---------------|---------------|---------------|-----------------------------------|---------------|---------------|-----|-----------|
| Case Number | Time Reported | Date Reported | Time Occurred | Date Occurred | Occurrence Between Date / Time of | Time Occurred | Date Occurred | 911 | Completed |
| 21-065953 | 01:06 | 11/29/21 | 01:06 | 11/29/21 | | | | X | X |

Incident Type:

Psych Case
Commitment

Incident Location:

Street # Street Name Intersection / Cross Street of:
 26 W Englewood Ave W Englewood Ave / Teaneck
 Business / Common Location Name

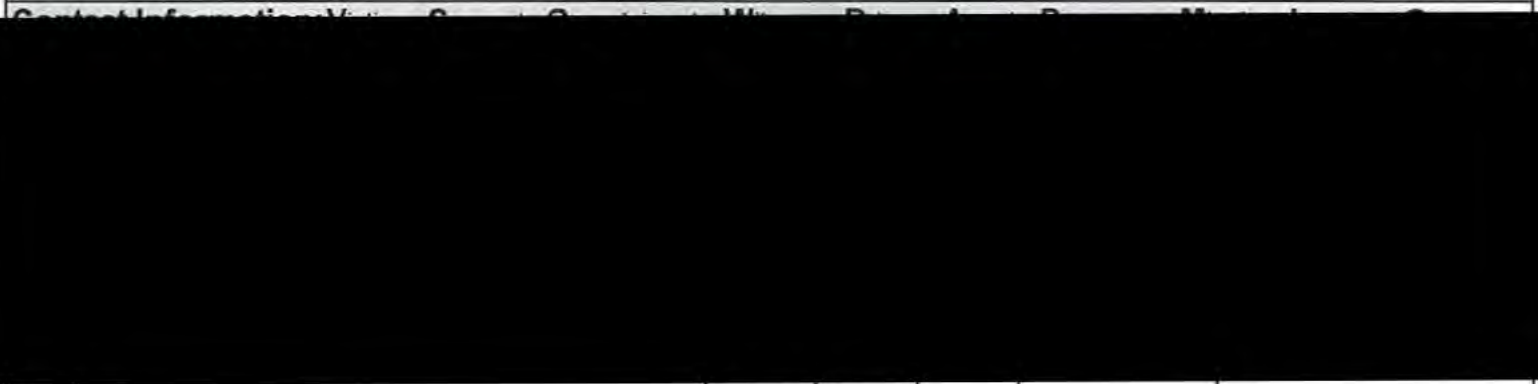

| | | | | | | | | |
|---------|-----------------|----|--------|-----|------------|------|------------|-----|
| Address | | | | | Home Phone | | Cell Phone | |
| Code | Contact Name #4 | MI | Suffix | Age | Sex | Race | DOB | SSN |
| Address | | | | | Home Phone | | Cell Phone | |

Property Information:

| | | | | | | | |
|------------------------------------|----------|---------|------|----------|------|-------|-------|
| Value of Stolen Property | Currency | Jewelry | Furs | Clothing | Auto | Misc. | Total |
| Value of Stolen Property Recovered | | | | | | | |

Automobile Information:

| 1 | Vehicle Code | Year | Make | Body Type | Model | Color | Registration | State | VIN |
|---|--------------|------|------|-----------|-------|-------|--------------|-------|-----|
| 2 | | | | | | | | | |
| 3 | | | | | | | | | |
| 4 | | | | | | | | | |

Narrative:

On Monday, November 29, 2021, at approximately 1:06 A.M., Sergeant R. Morales #306, Officer F. Tise #370, and I were dispatched to 26 West Englewood Avenue, on a report of a male party breaking items in the residence. I responded with emergency lights, audible sirens, and the Arbitrator Mobile Video Recorder activated.

| | | | | | | | | | | | | |
|---------------------------|--------------|-----------------------------|--------|-------|-----|------|------|-----|------|------|--|---------------------|
| Officer of Record: | Date: | Other Reports Filed: | | | | | | | | | | Reviewed By: |
| PO Justin Cochran 367 | 11/29/21 | MVA | Arrest | DV | DWI | DWIQ | Tow | SD | CI | TRO | | jgarland |
| | | SHA | Prop. | Video | UOF | Prst | Supp | Juv | Bias | Pris | | |



Teaneck Police Department

900 Teaneck Rd, Teaneck, NJ 07666

Phone: 201-837-2600 Fax: 201-837-1880 Mun. Code: 0260

Incident Report



Narrative Continued (Page 2)

Case Number

21-065952

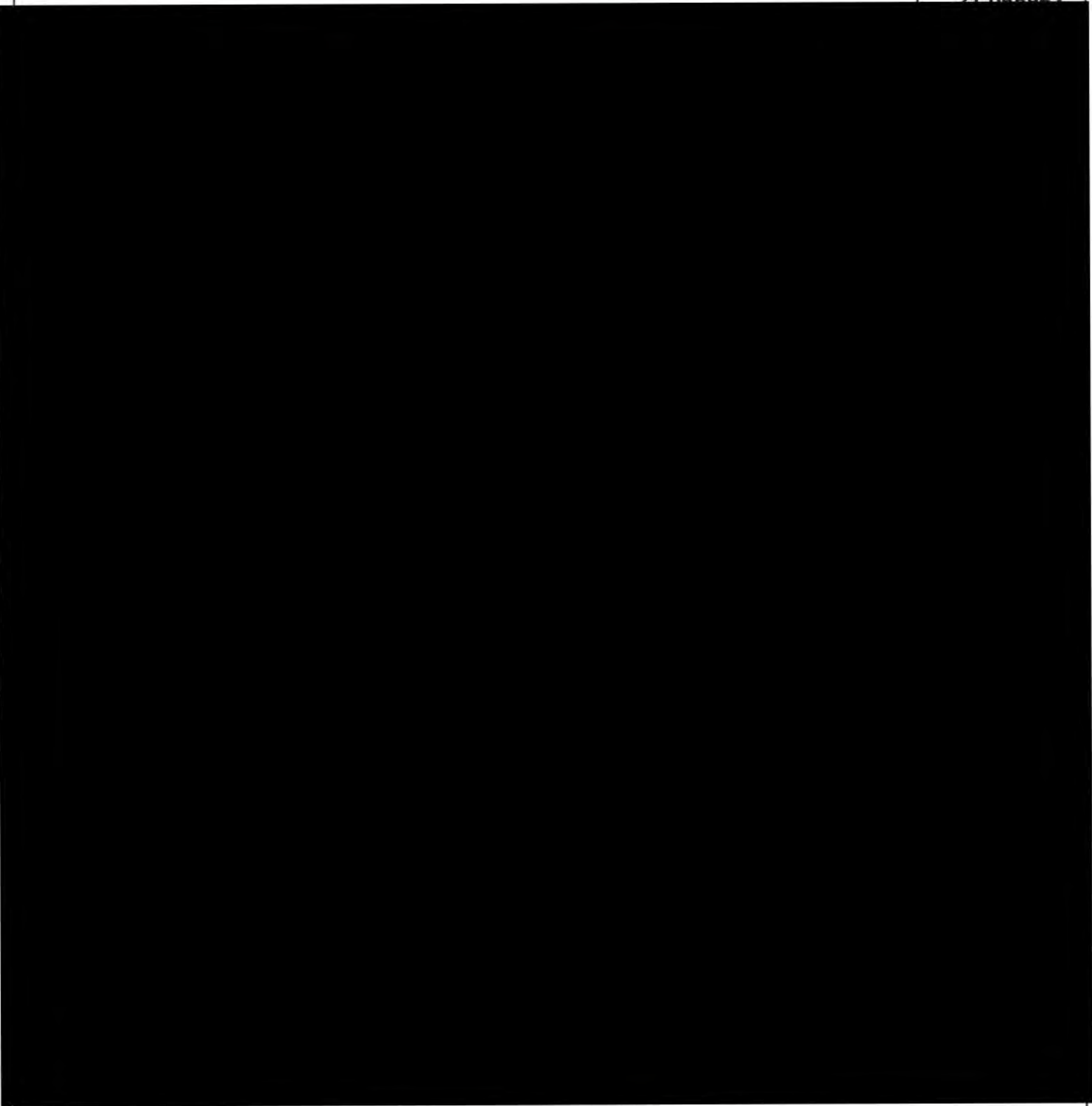

Officer of Record:

Date:

PO Justin Cochran 367

11/29/21



Teaneck Police Department

900 Teaneck Rd, Teaneck, NJ 07666

Phone: 201-837-2600 Fax: 201-837-1880 Mun. Code: 0260

Incident Report



Narrative Continued (Page 3)

Case Number

21-065953



Officer of Record:

Date:

PO Justin Cochran 367

11/29/21



Teaneck Police Department

900 Teaneck Rd, Teaneck, NJ 07666

Phone: 201-837-2600 Fax: 201-837-1880 Mun. Code: 0260

Incident Report



Incident Details:

| | | | | | | | | | |
|-------------|---------------|---------------|---------------|---------------|-----------------------------------|---------------|---------------|-----|-----------|
| Case Number | Time Reported | Date Reported | Time Occurred | Date Occurred | Occurrence Between Date / Time of | Time Occurred | Date Occurred | 911 | Completed |
| 21-071068 | 20:14 | 12/27/21 | 20:14 | 12/27/21 | | | | X | X |

| | |
|-----------------------|---|
| Incident Type: | Incident Location: |
| Missing Person | Street # Street Name 26 W Englewood Ave Intersection / Cross Street of: W Englewood Ave / Teaneck Business / Common Location Name |

Contact Information: Victim Suspect Complainant Witness Driver Arrest Recipient Missing Injured Other



| | | |
|---|------------|------------|
| Address | Home Phone | Cell Phone |
| Code Contact Name #4 MI Suffix Age Sex Race DOB SSN | | |
| Address | Home Phone | Cell Phone |

Property Information:

| | | | | | | | |
|------------------------------------|----------|---------|------|----------|------|-------|-------|
| Value of Stolen Property | Currency | Jewelry | Furs | Clothing | Auto | Misc. | Total |
| Value of Stolen Property Recovered | | | | | | | |

Automobile Information:

| 1 | Vehicle Code | Year | Make | Body Type | Model | Color | Registration | State | VIN |
|---|--------------|------|------|-----------|-------|-------|--------------|-------|-----|
| 2 | | | | | | | | | |
| 3 | | | | | | | | | |
| 4 | | | | | | | | | |

Narrative:

On Monday, December 27, 2021, at approximately 8:14 PM, Sergeant R. Boswell #308 Officer Graham #354 and I responded 26 West Englewood Avenue on a report of a missing person.

Upon arrival, I spoke with the caller, [REDACTED], who reported that her son [REDACTED] has not been seen since 9:30am on 12/27/2021.

Officer of Record: Date: Other Reports Filed: Reviewed By:

| | | |
|-----------------------------------|---|--------------|
| PO Michael Pellegrino 37112/27/21 | MVA Arrest DV DWI DWIQ Tow SD CI TRO SHA Prop. Video UOF Prst Supp 2 Juv Bias Pris | wbrittingham |
|-----------------------------------|---|--------------|



Teaneck Police Department

900 Teaneck Rd, Teaneck, NJ 07666

Phone: 201-837-2600 Fax: 201-837-1880 Mun. Code: 0260

Incident Report



Narrative Continued (Page 2)

Case Number

21-071068

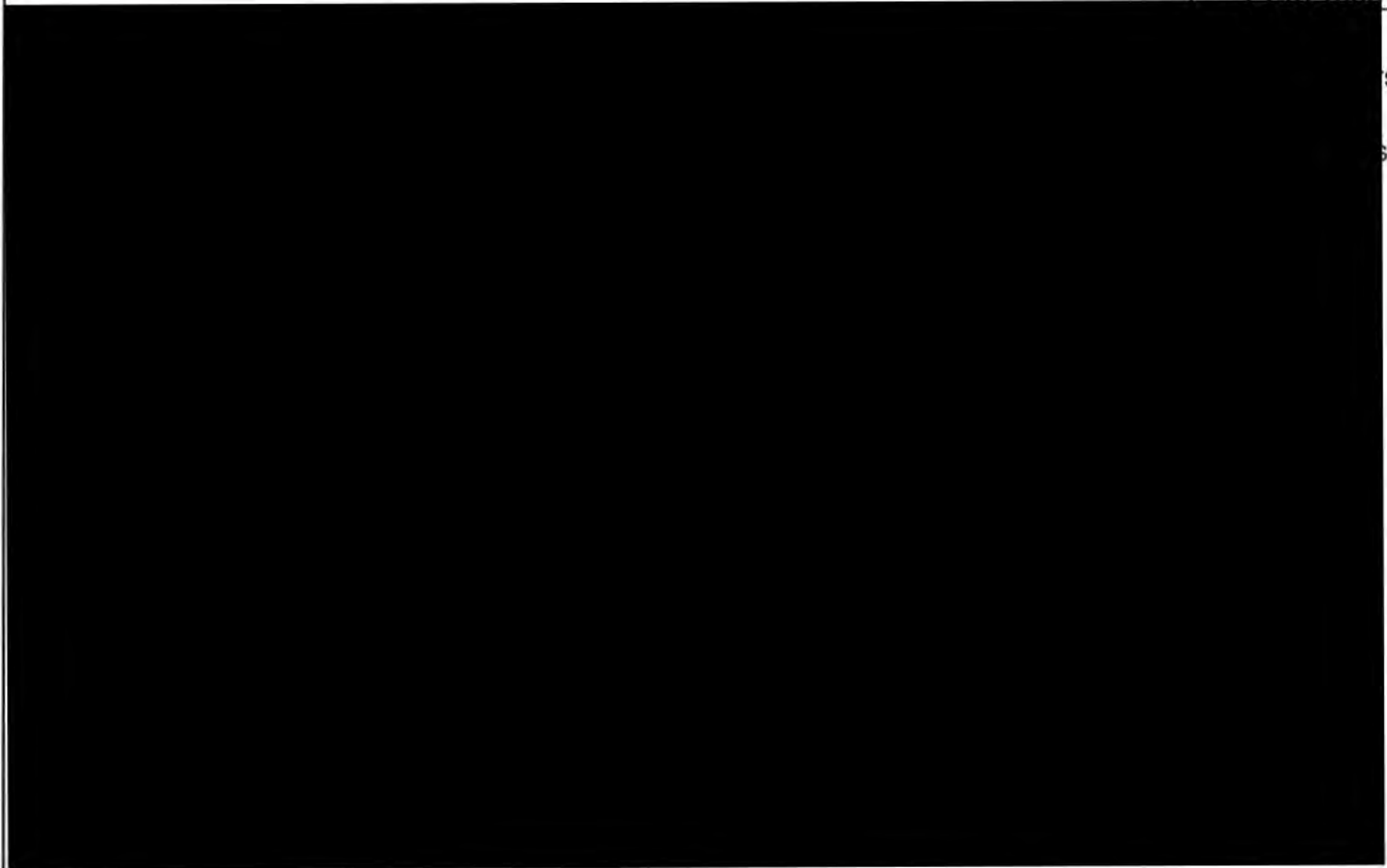

Officer of Record:

Date:

PO Michael Pellegrino 371

12/27/21



Teaneck Police Department

900 Teaneck Rd, Teaneck, NJ 07666

Phone: 201-837-2600 Fax: 201-837-1880 Mun. Code: 0260



Supplemental Investigation Report

| Incident Details: | | | | | | | | | |
|-------------------|---------------|---------------|---------------|---------------|-----------------------------------|---------------|---------------|-----|-----------|
| Case Number | Time Reported | Date Reported | Time Occurred | Date Occurred | Occurrence Between Date / Time of | Time Occurred | Date Occurred | 911 | Completed |
| 21-071068A | 03:51 | 12/28/21 | 03:51 | 12/28/21 | | | | | X |

| Incident Type: | Incident Location: |
|--|---|
| Investigation Follow-Up Missing Person Return | Street # Street Name 26 W Englewood Ave Intersection / Cross Street of: W Englewood Ave / Teaneck Business / Common Location Name |

Contact Information: Victim Suspect Complainant Witness Driver Arrest Party Missing Person Contact Other

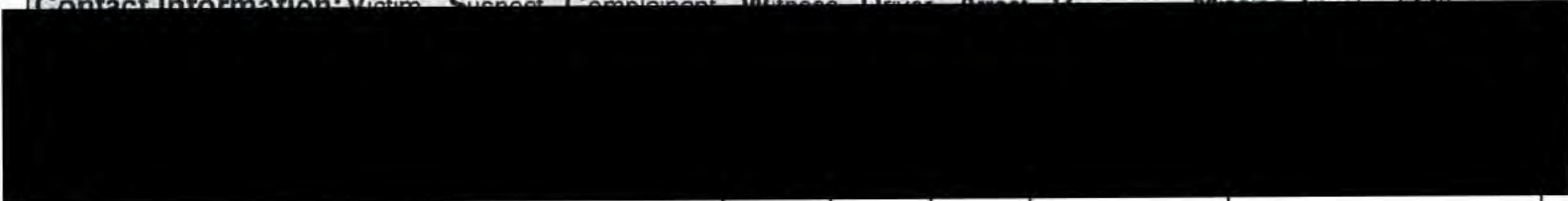

| | | | | | | | | | |
|---------|-----------------|----|--------|-----|-----|------------|-----|------------|--|
| Address | | | | | | Home Phone | | Cell Phone | |
| Code | Contact Name #3 | MI | Suffix | Age | Sex | Race | DOB | SSN | |
| Address | | | | | | Home Phone | | Cell Phone | |
| Code | Contact Name #4 | MI | Suffix | Age | Sex | Race | DOB | SSN | |
| Address | | | | | | Home Phone | | Cell Phone | |

| Property Information: | | | | | | | |
|------------------------------------|----------|---------|------|----------|------|-------|-------|
| Value of Stolen Property | Currency | Jewelry | Furs | Clothing | Auto | Misc. | Total |
| Value of Stolen Property Recovered | | | | | | | |

| Automobile Information: | | | | | | | | | |
|-------------------------|--------------|------|------|-----------|-------|-------|--------------|-------|-----|
| 1 | Vehicle Code | Year | Make | Body Type | Model | Color | Registration | State | VIN |
| 2 | | | | | | | | | |
| 3 | | | | | | | | | |
| 4 | | | | | | | | | |

Narrative:

On Tuesday, December 28, 2021, at approximately 3:51 AM, The Stroud Area Regional Police Department contacted the Teaneck Police Department with a HIT confirmation regarding a missing person out of our jurisdiction [REDACTED] PO R. Overpeck #0001 of the Stroud Area Regional Police Department arrested [REDACTED] see their departments report #2021-028781 for further information.

Once confirmed, a Return of a Missing Persons Form was completed and [REDACTED] was removed from NCIC as a missing person (NIC #M326546349) by Dispatcher Cullen. For further info regarding this case see report #21-071068.

| Officer of Record: | Date: | Other Reports Filed: | Reviewed By: |
|-----------------------|------------|---|--------------|
| PO Michael Pellegrino | 3712/28/21 | MVA Arrest DV DWI DWIQ Tow SD CI TRO SHA Prop. Video UOF Prst Supp 2 Juv Bias Pris | wbrittingham |



Teaneck Police Department

900 Teaneck Rd, Teaneck, NJ 07666

Phone: 201-837-2600 Fax: 201-837-1880 Mun. Code: 0260

CAD Report



| Incident Details: | | | Incident Location: | | Disposition |
|-------------------|-------|----------|--------------------------------|--|------------------|
| Case Number | Time | Date | Address | | Disposition |
| PD-17-034070 | 22:03 | 09/14/17 | 22 WEST ENGLEWOOD AVE, TEANECK | | Report Completed |

| Incident Type: | | Dispatched By | | Created By | |
|--------------------------------|---------|-----------------|---------|--------------|---------|
| First Aid / Medical Assistance | | Ndeca | | Ndeca | |
| Unit | Officer | Unit | Officer | Unit | Officer |
| 347 | Wdrin | | | | |
| Time Received | | Time Dispatched | | Time Arrived | |
| 2203 | | 2205 | | 2206 | |
| | | | | Time Cleared | |
| | | | | 2218 | |

| Contact Information: | | | | | |
|----------------------|--------------|---------|-----|-----|-------|
| Role | Contact Name | Address | DOB | Sex | Phone |
| | | | | | |
| | | | | | |
| | | | | | |
| | | | | | |
| | | | | | |
| | | | | | |
| | | | | | |
| | | | | | |
| | | | | | |

| Auto Information: | | | | | | |
|-------------------|-------|------|-------|-------|------|-----|
| Registration | State | Make | Model | Color | Year | VIN |
| | | | | | | |
| | | | | | | |
| | | | | | | |
| | | | | | | |
| | | | | | | |
| | | | | | | |
| | | | | | | |
| | | | | | | |
| | | | | | | |

| Summonses: | | | | |
|---------------|------|-----------|------|---------|
| Ticket Number | Date | Violation | Name | Officer |
| | | | | |
| | | | | |
| | | | | |
| | | | | |
| | | | | |
| | | | | |
| | | | | |
| | | | | |
| | | | | |

Narrative:
 Input ndeca 09 14 2017 22 04 14 Edited ndeca 09 14 2017 22 04 14 30YO MALE NOT FEELING WELL MIGHT PASS OUT
 Input ndeca 09 14 2017 22 04 48 Edited ndeca 09 14 2017 22 04 48 201 575 8085 WILL BE OUTSIDE
 Input ndeca 09 14 2017 22 05 27 Edited ndeca 09 14 2017 22 05 27 TVAC CONTACTED Input ndeca 09 14 2017 22 17 34 Edited ndeca 09 14 2017 22 17 34 1 TO HNH



Teaneck Police Department

900 Teaneck Rd, Teaneck, NJ 07666

Phone: 201-837-2600 Fax: 201-837-1880 Mun. Code: 0260

Incident Report



Incident Details:

| | | | | | | | | | |
|-------------|---------------|---------------|---------------|---------------|-----------------------------------|---------------|---------------|-----|-----------|
| Case Number | Time Reported | Date Reported | Time Occurred | Date Occurred | Occurrence Between Date / Time of | Time Occurred | Date Occurred | 911 | Completed |
| 18-037384 | 00:36 | 08/10/18 | 00:36 | 08/10/18 | | | | | X |

Incident Type:

Medical Emergency

Incident Location:

| | | |
|---------------------------------|-----------------|---------------------------------|
| Street # | Street Name | Intersection / Cross Street of: |
| 22 | W Englewood Ave | W Englewood Ave / Teaneck |
| Business / Common Location Name | | |

Contact Information: Victim Suspect Complainant Witness Driver Arrest Recipient Missing Involved Other

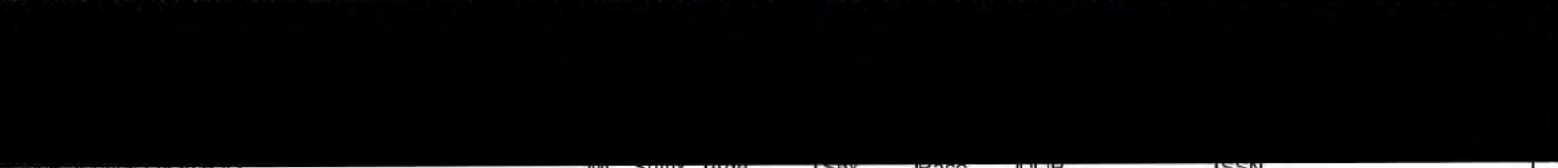

| | | | | | | | | |
|---------|-----------------|----|--------|-----|-----|------------|------------|-----|
| Code | Contact Name #2 | MI | Suffix | Age | Sex | Race | DOB | SSN |
| Address | | | | | | Home Phone | Cell Phone | |
| Code | Contact Name #3 | MI | Suffix | Age | Sex | Race | DOB | SSN |
| Address | | | | | | Home Phone | Cell Phone | |
| Code | Contact Name #4 | MI | Suffix | Age | Sex | Race | DOB | SSN |
| Address | | | | | | Home Phone | Cell Phone | |

Property Information:

| | | | | | | | |
|------------------------------------|----------|---------|------|----------|------|-------|-------|
| Value of Stolen Property | Currency | Jewelry | Furs | Clothing | Auto | Misc. | Total |
| Value of Stolen Property Recovered | | | | | | | |

Automobile Information:

| 1 | Vehicle Code | Year | Make | Body Type | Model | Color | Registration | State | VIN |
|---|--------------|------|------|-----------|-------|-------|--------------|-------|-----|
| 2 | | | | | | | | | |
| 3 | | | | | | | | | |
| 4 | | | | | | | | | |

Narrative:

On Friday August 10, 2018 at 12:36 AM, Teaneck Volunteer Ambulance Corp. (TVAC) and I responded to 22 W Englewood Ave Apt 2, on a report of a female with back pain. Upon my arrival, I met with the caller [REDACTED]. Shortly after, she was transported to Englewood Hospital by TVAC.

| | | | |
|---------------------------|--------------|---|---------------------|
| Officer of Record: | Date: | Other Reports Filed: | Reviewed By: |
| PO Jon-Ryan Meyer 340 | 08/10/18 | MVA Arrest DV DWI DWIQ Tow SD CI TRO SHA Prop. Video UOF Prst Supp Juv Bias Pris | kjohnson |



Teaneck Police Department

900 Teaneck Rd, Teaneck, NJ 07666

Phone: 201-837-2600 Fax: 201-837-1880 Mun. Code: 0260

Incident Report



| Incident Details: | | | | | | | | | |
|-------------------|---------------|---------------|---------------|---------------|-----------------------------------|---------------|---------------|-----|-----------|
| Case Number | Time Reported | Date Reported | Time Occurred | Date Occurred | Occurrence Between Date / Time of | Time Occurred | Date Occurred | 911 | Completed |
| 18-038390 | 08:07 | 08/15/18 | 08:07 | 08/15/18 | | | | X | X |

| Incident Type: | Incident Location: |
|-------------------|--|
| Medical Emergency | Street # Street Name Intersection / Cross Street of: 22 W Englewood Ave W Englewood Ave / Teaneck |
| | Business / Common Location Name |

Contact Information: Victim Suspect Complainant Witness Driver Arrest Passenger Missing Involved Other



| | | | | | | | | |
|---------|-----------------|----|--------|-----|-----|------------|------------|-----|
| Code | Contact Name #2 | MI | Suffix | Age | Sex | Race | DOB | SSN |
| Address | | | | | | Home Phone | Cell Phone | |
| Code | Contact Name #3 | MI | Suffix | Age | Sex | Race | DOB | SSN |
| Address | | | | | | Home Phone | Cell Phone | |
| Code | Contact Name #4 | MI | Suffix | Age | Sex | Race | DOB | SSN |
| Address | | | | | | Home Phone | Cell Phone | |

| Property Information: | | | | | | | |
|------------------------------------|----------|---------|------|----------|------|-------|-------|
| Value of Stolen Property | Currency | Jewelry | Furs | Clothing | Auto | Misc. | Total |
| Value of Stolen Property Recovered | | | | | | | |

| Automobile Information: | | | | | | | | | |
|-------------------------|--------------|------|------|-----------|-------|-------|--------------|-------|-----|
| 1 | Vehicle Code | Year | Make | Body Type | Model | Color | Registration | State | VIN |
| 2 | | | | | | | | | |
| 3 | | | | | | | | | |
| 4 | | | | | | | | | |

Narrative:
 On Wednesday, August 15, 2018, I responded, along with TVAC ambulance 75 to 22 West Englewood Avenue, Apt. 2, on a report of a party with back pain [REDACTED] was transported to Englewood Hospital.

| Officer of Record: | Date: | Other Reports Filed: | Reviewed By: |
|----------------------|----------|---|--------------|
| PO Raymond Byrne 234 | 08/15/18 | MVA Arrest DV DWI DWIQ Tow SD CI TRO SHA Prop. Video UOF Prst Supp Juv Bias Pris | dalcott |



Teaneck Police Department

900 Teaneck Rd, Teaneck, NJ 07666

Phone: 201-837-2600 Fax: 201-837-1880 Mun. Code: 0260

Incident Report



Incident Details:

| | | | | | | | | | |
|-------------|---------------|---------------|---------------|---------------|-----------------------------------|---------------|---------------|-----|-----------|
| Case Number | Time Reported | Date Reported | Time Occurred | Date Occurred | Occurrence Between Date / Time of | Time Occurred | Date Occurred | 911 | Completed |
| 18-040060 | 10:44 | 08/23/18 | 10:44 | 08/23/18 | | | | X | X |

| | |
|-----------------------|--|
| Incident Type: | Incident Location: |
| Medical Emergency | Street # Street Name Intersection / Cross Street of: 22 W Englewood Ave W Englewood Ave / Teaneck |
| | Business / Common Location Name |

Contact Information: Victim: Support: Complainant: Witness: Driver: Arrest: Defendant: Must be 18

| | | | | | | | | |
|---------|-----------------|----|--------|-----|-----|------------|-----|------------|
| Code | Contact Name #3 | MI | Suffix | Age | Sex | Race | DOB | SSN |
| Address | | | | | | Home Phone | | Cell Phone |
| Code | Contact Name #4 | MI | Suffix | Age | Sex | Race | DOB | SSN |
| Address | | | | | | Home Phone | | Cell Phone |

| | | | | | | | |
|------------------------------------|----------|---------|------|----------|------|-------|-------|
| Property Information: | | | | | | | |
| Value of Stolen Property | Currency | Jewelry | Furs | Clothing | Auto | Misc. | Total |
| Value of Stolen Property Recovered | | | | | | | |

| | | | | | | | | | |
|--------------------------------|--------------|------|------|-----------|-------|-------|--------------|-------|-----|
| Automobile Information: | | | | | | | | | |
| 1 | Vehicle Code | Year | Make | Body Type | Model | Color | Registration | State | VIN |
| 2 | | | | | | | | | |
| 3 | | | | | | | | | |
| 4 | | | | | | | | | |

Narrative:
Complaint of back pain. Transported to Englewood Hospital by TVAC.

| | | | | | | | | | | | | |
|---------------------------|--------------|-----------------------------|--------|-------|-----|------|------|-----|------|------|--|---------------------|
| Officer of Record: | Date: | Other Reports Filed: | | | | | | | | | | Reviewed By: |
| PO Kevin Florio 349 | 08/23/18 | MVA | Arrest | DV | DWI | DWIQ | Tow | SD | CI | TRO | | jgarland |
| | | SHA | Prop. | Video | UOF | Prst | Supp | Juv | Bias | Pris | | |



Teaneck Police Department

900 Teaneck Rd, Teaneck, NJ 07666

Phone: 201-837-2600 Fax: 201-837-1880 Mun. Code: 0260

Incident Report



Incident Details:

| | | | | | | | | | |
|-------------|---------------|---------------|---------------|---------------|-----------------------------------|---------------|---------------|-----|-----------|
| Case Number | Time Reported | Date Reported | Time Occurred | Date Occurred | Occurrence Between Date / Time of | Time Occurred | Date Occurred | 911 | Completed |
| 18-044047 | 07:48 | 09/12/18 | 07:48 | 09/12/18 | | | | X | X |

| | | | | | | | | | | |
|-----------------------|--|--|---------------------------------|-----------------|--|--|---------------------------------|--|--|--|
| Incident Type: | | | Incident Location: | | | | | | | |
| Medical Emergency | | | Street # | Street Name | | | Intersection / Cross Street of: | | | |
| | | | 22 | W Englewood Ave | | | W Englewood Ave / Teaneck | | | |
| | | | Business / Common Location Name | | | | | | | |

Contact Information: Victim Suspect Complainant Witness Driver Arrest Passenger Missing Involved Other

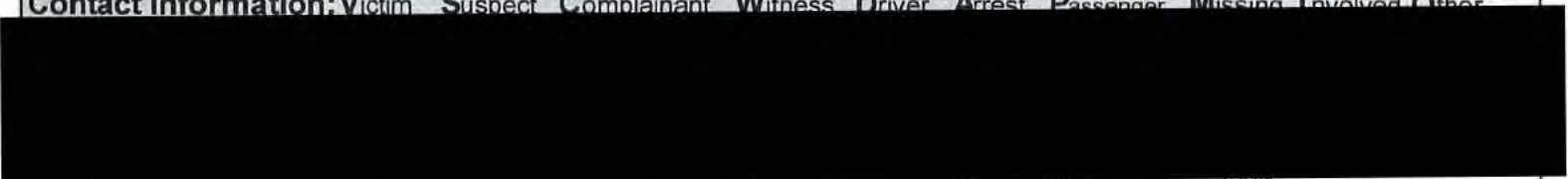

| | | | | | | | | | |
|---------|-----------------|----|--------|-----|------------|------------|-----|-----|--|
| Address | | | | | Home Phone | Cell Phone | | | |
| Code | Contact Name #3 | MI | Suffix | Age | Sex | Race | DOB | SSN | |
| Address | | | | | Home Phone | Cell Phone | | | |
| Code | Contact Name #4 | MI | Suffix | Age | Sex | Race | DOB | SSN | |
| Address | | | | | Home Phone | Cell Phone | | | |

Property Information:

| | | | | | | | |
|------------------------------------|----------|---------|------|----------|------|-------|-------|
| Value of Stolen Property | Currency | Jewelry | Furs | Clothing | Auto | Misc. | Total |
| Value of Stolen Property Recovered | | | | | | | |

Automobile Information:

| 1 | Vehicle Code | Year | Make | Body Type | Model | Color | Registration | State | VIN |
|---|--------------|------|------|-----------|-------|-------|--------------|-------|-----|
| 2 | | | | | | | | | |
| 3 | | | | | | | | | |
| 4 | | | | | | | | | |

Narrative:

complained of severe back pain, prior to transport to Englewood Hospital.

Officer of Record: **Date:** **Other Reports Filed:** **Reviewed By:**

| | | | |
|----------------------|----------|---|--------|
| PO Patrick Haase 341 | 09/12/18 | MVA Arrest DV DWI DWIQ Tow SD CI TRO SHA Prop. Video UOF Prst Supp Juv Bias Pris | ttully |
|----------------------|----------|---|--------|



Teaneck Police Department

900 Teaneck Rd, Teaneck, NJ 07666

Phone: 201-837-2600 Fax: 201-837-1880 Mun. Code: 0260

Incident Report



| Incident Details: | | | | | | | | | |
|-------------------|---------------|---------------|---------------|---------------|-----------------------------------|---------------|---------------|-----|-----------|
| Case Number | Time Reported | Date Reported | Time Occurred | Date Occurred | Occurrence Between Date / Time of | Time Occurred | Date Occurred | 911 | Completed |
| 18-045221 | 22:03 | 09/17/18 | 22:03 | 09/17/18 | | | | X | X |

| Incident Type: | | | Incident Location: | | |
|-------------------|--|--|---------------------------------|-----------------|---------------------------------|
| Medical Emergency | | | Street # | Street Name | Intersection / Cross Street of: |
| | | | 22 | W Englewood Ave | W Englewood Ave / Teaneck |
| | | | Business / Common Location Name | | |

Contact Information: Victim Suspect Complainant Witness Driver Arrest Passenger Missing Involved Other



| | | |
|---|------------|------------|
| Address | Home Phone | Cell Phone |
| Code Contact Name #3 MI Suffix Age Sex Race DOB SSN | | |
| Address | Home Phone | Cell Phone |
| Code Contact Name #4 MI Suffix Age Sex Race DOB SSN | | |
| Address | Home Phone | Cell Phone |

| Property Information: | | | | | | | |
|------------------------------------|----------|---------|------|----------|------|-------|-------|
| Value of Stolen Property | Currency | Jewelry | Furs | Clothing | Auto | Misc. | Total |
| Value of Stolen Property Recovered | | | | | | | |

| Automobile Information: | | | | | | | | | |
|-------------------------|--------------|------|------|-----------|-------|-------|--------------|-------|-----|
| 1 | Vehicle Code | Year | Make | Body Type | Model | Color | Registration | State | VIN |
| 2 | | | | | | | | | |
| 3 | | | | | | | | | |
| 4 | | | | | | | | | |

Narrative:

| Officer of Record: | Date: | Other Reports Filed: | Reviewed By: |
|---------------------|----------|---|--------------|
| PO James Hoover 339 | 09/17/18 | MVA Arrest DV DWI DWIQ Tow SD CI TRO SHA Prop. Video UOF Prst Supp Juv Bias Pris | kegbert |



Teaneck Police Department

900 Teaneck Rd, Teaneck, NJ 07666

Phone: 201-837-2600 Fax: 201-837-1880 Mun. Code: 0260

Incident Report



Incident Details:

| | | | | | | | | | |
|-------------|---------------|---------------|---------------|---------------|-----------------------------------|---------------|---------------|-----|-----------|
| Case Number | Time Reported | Date Reported | Time Occurred | Date Occurred | Occurrence Between Date / Time of | Time Occurred | Date Occurred | 911 | Completed |
| 18-045505 | 11:08 | 09/19/18 | 11:08 | 09/20/18 | | | | X | X |

Incident Type:

Medical Emergency

Incident Location:

| | | |
|---------------------------------|-----------------|---------------------------------|
| Street # | Street Name | Intersection / Cross Street of: |
| 22 | W Englewood Ave | W Englewood Ave / Teaneck |
| Business / Common Location Name | | |

Contact Information: Victim Suspect Complainant Witness Driver Arrest Passenger Missing Involved Other

| | | | | | | | | |
|---------|-----------------|----|--------|-----|-----|------------|------------|-----|
| Code | Contact Name #2 | MI | Suffix | Age | Sex | Race | DOB | SSN |
| Address | | | | | | Home Phone | Cell Phone | |
| Code | Contact Name #3 | MI | Suffix | Age | Sex | Race | DOB | SSN |
| Address | | | | | | Home Phone | Cell Phone | |
| Code | Contact Name #4 | MI | Suffix | Age | Sex | Race | DOB | SSN |
| Address | | | | | | Home Phone | Cell Phone | |

Property Information:

| | | | | | | | |
|------------------------------------|----------|---------|------|----------|------|-------|-------|
| Value of Stolen Property | Currency | Jewelry | Furs | Clothing | Auto | Misc. | Total |
| Value of Stolen Property Recovered | | | | | | | |

Automobile Information:

| 1 | Vehicle Code | Year | Make | Body Type | Model | Color | Registration | State | VIN |
|---|--------------|------|------|-----------|-------|-------|--------------|-------|-----|
| 2 | | | | | | | | | |
| 3 | | | | | | | | | |
| 4 | | | | | | | | | |

Narrative:

One to Holy Name Medical Center.

Officer of Record: Date: Other Reports Filed: Reviewed By:

| | | | |
|----------------------|----------|---|---------|
| PO Michael Ayala 332 | 09/19/18 | MVA Arrest DV DWI DWIQ Tow SD CI TRO | dalcott |
| | | SHA Prop. Video UOF Prst Supp Juv Bias Pris | |



Teaneck Police Department

900 Teaneck Rd, Teaneck, NJ 07666

Phone: 201-837-2600 Fax: 201-837-1880 Mun. Code: 0260

Incident Report



Incident Details:

| | | | | | | | | | |
|-------------|---------------|---------------|---------------|---------------|-----------------------------------|---------------|---------------|-----|-----------|
| Case Number | Time Reported | Date Reported | Time Occurred | Date Occurred | Occurrence Between Date / Time of | Time Occurred | Date Occurred | 911 | Completed |
| 18-045720 | 08:59 | 09/20/18 | 08:59 | 09/20/18 | | | | X | X |

Incident Type:

Medical Emergency

Incident Location:

Street # Street Name Intersection / Cross Street of:
 22 W Englewood Ave W Englewood Ave / Teaneck
 Business / Common Location Name

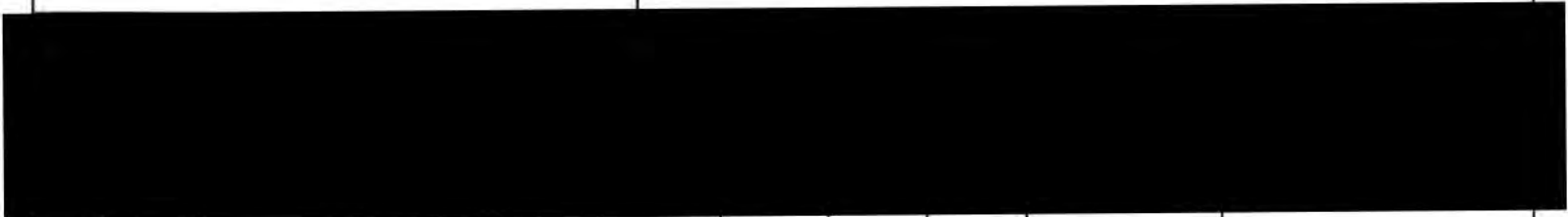

| | | | | | | | | | |
|---------|-----------------|----|--------|-----|-----|------------|-----|------------|--|
| Address | | | | | | Home Phone | | Cell Phone | |
| Code | Contact Name #3 | MI | Suffix | Age | Sex | Race | DOB | SSN | |
| Address | | | | | | Home Phone | | Cell Phone | |
| Code | Contact Name #4 | MI | Suffix | Age | Sex | Race | DOB | SSN | |
| Address | | | | | | Home Phone | | Cell Phone | |

Property Information:

| | | | | | | | |
|------------------------------------|----------|---------|------|----------|------|-------|-------|
| Value of Stolen Property | Currency | Jewelry | Furs | Clothing | Auto | Misc. | Total |
| Value of Stolen Property Recovered | | | | | | | |

Automobile Information:

| 1 | Vehicle Code | Year | Make | Body Type | Model | Color | Registration | State | VIN |
|---|--------------|------|------|-----------|-------|-------|--------------|-------|-----|
| 2 | | | | | | | | | |
| 3 | | | | | | | | | |
| 4 | | | | | | | | | |

Narrative:

One to Holy Name Medical Center.

Officer of Record:

Date:

Other Reports Filed:

Reviewed By:

| | | | | |
|----------------------|----------|--------------------------------------|---|---------|
| PO Michael Ayala 332 | 09/20/18 | MVA Arrest DV DWI DWIQ Tow SD CI TRO | SHA Prop. Video UOF Prst Supp Juv Bias Pris | dalcott |
|----------------------|----------|--------------------------------------|---|---------|



Teaneck Police Department

900 Teaneck Rd, Teaneck, NJ 07666

Phone: 201-837-2600 Fax: 201-837-1880 Mun. Code: 0260

Incident Report



Incident Details:

| | | | | | | | | | |
|-------------|---------------|---------------|---------------|---------------|-----------------------------------|---------------|---------------|-----|-----------|
| Case Number | Time Reported | Date Reported | Time Occurred | Date Occurred | Occurrence Between Date / Time of | Time Occurred | Date Occurred | 911 | Completed |
| 18-058416 | 12:00 | 11/26/18 | 12:00 | 11/26/18 | | | | | X |

Incident Type:

Medical Emergency

Incident Location:

Street # Street Name Intersection / Cross Street of:
 22 W Englewood Ave W Englewood Ave / Teaneck
 Business / Common Location Name

Contact Information: Victim Suspect Complainant Witness Driver Arrest Passenger Missing Involved Other

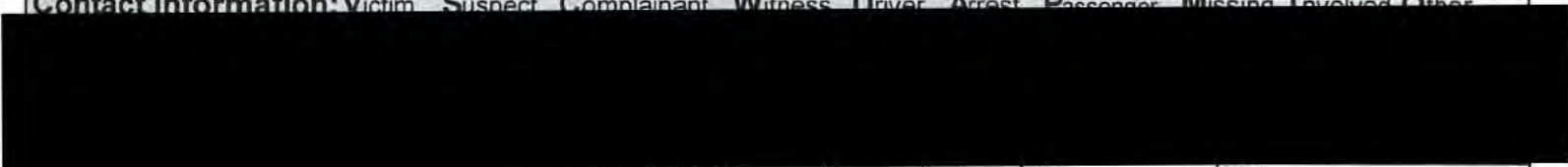

| | | | | | | | | |
|------|-----------------|----|--------|-----|-----|------|-----|-----|
| Code | Contact Name #2 | MI | Suffix | Age | Sex | Race | DOB | SSN |
|------|-----------------|----|--------|-----|-----|------|-----|-----|

| | | |
|---------|------------|------------|
| Address | Home Phone | Cell Phone |
|---------|------------|------------|

| | | | | | | | | |
|------|-----------------|----|--------|-----|-----|------|-----|-----|
| Code | Contact Name #3 | MI | Suffix | Age | Sex | Race | DOB | SSN |
|------|-----------------|----|--------|-----|-----|------|-----|-----|

| | | |
|---------|------------|------------|
| Address | Home Phone | Cell Phone |
|---------|------------|------------|

| | | | | | | | | |
|------|-----------------|----|--------|-----|-----|------|-----|-----|
| Code | Contact Name #4 | MI | Suffix | Age | Sex | Race | DOB | SSN |
|------|-----------------|----|--------|-----|-----|------|-----|-----|

| | | |
|---------|------------|------------|
| Address | Home Phone | Cell Phone |
|---------|------------|------------|

Property Information:

| | | | | | | | |
|--------------------------|----------|---------|------|----------|------|-------|-------|
| Value of Stolen Property | Currency | Jewelry | Furs | Clothing | Auto | Misc. | Total |
|--------------------------|----------|---------|------|----------|------|-------|-------|

| | | | | | | | |
|------------------------------------|--|--|--|--|--|--|--|
| Value of Stolen Property Recovered | | | | | | | |
|------------------------------------|--|--|--|--|--|--|--|

Automobile Information:

| 1 | Vehicle Code | Year | Make | Body Type | Model | Color | Registration | State | VIN |
|---|--------------|------|------|-----------|-------|-------|--------------|-------|-----|
| 2 | | | | | | | | | |
| 3 | | | | | | | | | |
| 4 | | | | | | | | | |

Narrative:

One transported to Holy Name.

Officer of Record:

PO Philip Apreda 330

Date:

11/26/18

Other Reports Filed:

MVA Arrest DV DWI DWIQ Tow SD CI TRO
 SHA Prop. Video UOF Prst Supp Juv Bias Pris

Reviewed By:

pforrest



Teaneck Police Department

900 Teaneck Rd, Teaneck, NJ 07666

Phone: 201-837-2600 Fax: 201-837-1880 Mun. Code: 0260

Incident Report



Incident Details:

| | | | | | | | | | |
|-------------|---------------|---------------|---------------|---------------|-----------------------------------|---------------|---------------|-----|-----------|
| Case Number | Time Reported | Date Reported | Time Occurred | Date Occurred | Occurrence Between Date / Time of | Time Occurred | Date Occurred | 911 | Completed |
| 19-016078 | 12:39 | 03/23/19 | 12:39 | 03/23/19 | | | | X | X |

Incident Type:

Medical Emergency

Incident Location:

| | | |
|---------------------------------|-----------------|---------------------------------|
| Street # | Street Name | Intersection / Cross Street of: |
| 22 | W Englewood Ave | W Englewood Ave / Teaneck |
| Business / Common Location Name | | |

Contact Information: Victim Suspect Complainant Witness Driver Arrest Passenger Missing Involved Other

| | | |
|---|------------|------------|
| Address | Home Phone | Cell Phone |
| Code Contact Name #3 MI Suffix Age Sex Race DOB SSN | | |
| Address | Home Phone | Cell Phone |
| Code Contact Name #4 MI Suffix Age Sex Race DOB SSN | | |
| Address | Home Phone | Cell Phone |

Property Information:

| | | | | | | | |
|------------------------------------|----------|---------|------|----------|------|-------|-------|
| Value of Stolen Property | Currency | Jewelry | Furs | Clothing | Auto | Misc. | Total |
| Value of Stolen Property Recovered | | | | | | | |

Automobile Information:

| 1 | Vehicle Code | Year | Make | Body Type | Model | Color | Registration | State | VIN |
|---|--------------|------|------|-----------|-------|-------|--------------|-------|-----|
| 2 | | | | | | | | | |
| 3 | | | | | | | | | |
| 4 | | | | | | | | | |

Narrative:

One transported to Holy Name.

Officer of Record: Date: Other Reports Filed: Reviewed By:

| | | | |
|----------------------|----------|---|----------|
| PO Philip Apreda 330 | 03/23/19 | MVA Arrest DV DWI DWIQ Tow SD CI TRO SHA Prop. Video UOF Prst Supp Juv Bias Pris | pforrest |
|----------------------|----------|---|----------|



Teaneck Police Department

900 Teaneck Rd, Teaneck, NJ 07666

Phone: 201-837-2600 Fax: 201-837-1880 Mun. Code: 0260

Incident Report



Incident Details:

| | | | | | | | | | |
|-------------|---------------|---------------|---------------|---------------|-----------------------------------|---------------|---------------|-----|-----------|
| Case Number | Time Reported | Date Reported | Time Occurred | Date Occurred | Occurrence Between Date / Time of | Time Occurred | Date Occurred | 911 | Completed |
| 19-056409 | 23:52 | 10/14/19 | 23:52 | 10/14/19 | | | | | X |

Incident Type:

Medical Emergency

Incident Location:

Street # Street Name Intersection / Cross Street of:
 22 W Englewood Ave W Englewood Ave / Teaneck
 Business / Common Location Name

Contact Information: Victim Suspect Complainant Witness Driver Arrest Passenger Missing Involved Other

| | | | | | | | | |
|---------|-----------------|----|--------|-----|-----|------------|------------|-----|
| Code | Contact Name #2 | MI | Suffix | Age | Sex | Race | DOB | SSN |
| Address | | | | | | Home Phone | Cell Phone | |
| Code | Contact Name #3 | MI | Suffix | Age | Sex | Race | DOB | SSN |
| Address | | | | | | Home Phone | Cell Phone | |
| Code | Contact Name #4 | MI | Suffix | Age | Sex | Race | DOB | SSN |
| Address | | | | | | Home Phone | Cell Phone | |

Property Information:

| | | | | | | | |
|------------------------------------|----------|---------|------|----------|------|-------|-------|
| Value of Stolen Property | Currency | Jewelry | Furs | Clothing | Auto | Misc. | Total |
| Value of Stolen Property Recovered | | | | | | | |

Automobile Information:

| 1 | Vehicle Code | Year | Make | Body Type | Model | Color | Registration | State | VIN |
|---|--------------|------|------|-----------|-------|-------|--------------|-------|-----|
| 2 | | | | | | | | | |
| 3 | | | | | | | | | |
| 4 | | | | | | | | | |

Narrative:

TVAC transported one male party to Englewood Hospital.

Officer of Record: PO Nicholas Ruscigno **Date:** 10/14/19 **Other Reports Filed:** MVA Arrest DV DWI DWIQ Tow SD CI TRO SHA Prop. Video UOF Prst Supp Juv Bias Pris **Reviewed By:** dquinn



Teaneck Police Department

900 Teaneck Rd, Teaneck, NJ 07666

Phone: 201-837-2600 Fax: 201-837-1880 Mun. Code: 0260

Incident Report



Incident Details:

| | | | | | | | | | |
|-------------|---------------|---------------|---------------|---------------|-----------------------------------|---------------|---------------|-----|-----------|
| Case Number | Time Reported | Date Reported | Time Occurred | Date Occurred | Occurrence Between Date / Time of | Time Occurred | Date Occurred | 911 | Completed |
| 19-061144 | 06:40 | 11/08/19 | 06:40 | 11/08/19 | | | | X | X |

Incident Type:

Medical Emergency

Incident Location:

| | | |
|---------------------------------|-----------------|---------------------------------|
| Street # | Street Name | Intersection / Cross Street of: |
| 22 | W Englewood Ave | W Englewood Ave / Teaneck |
| Business / Common Location Name | | |

Contact Information: Victim Suspect Complainant Witness Driver Arrest Recusor Missing Involved Other

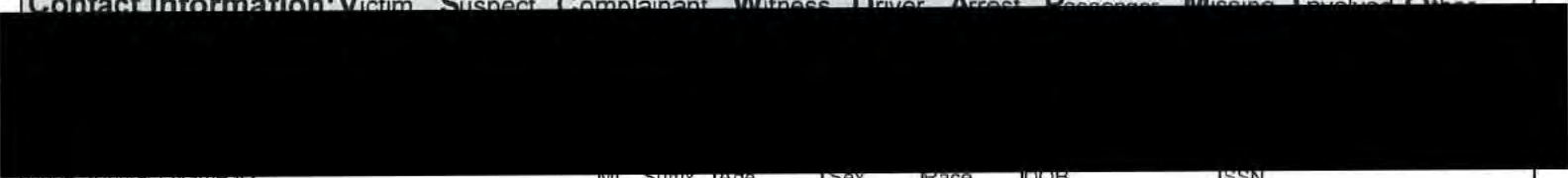

| | | | | | | | | |
|---------|-----------------|----|--------|-----|-----|------------|------------|-----|
| Code | Contact Name #2 | MI | Suffix | Age | Sex | Race | DOB | SSN |
| Address | | | | | | Home Phone | Cell Phone | |
| Code | Contact Name #3 | MI | Suffix | Age | Sex | Race | DOB | SSN |
| Address | | | | | | Home Phone | Cell Phone | |
| Code | Contact Name #4 | MI | Suffix | Age | Sex | Race | DOB | SSN |
| Address | | | | | | Home Phone | Cell Phone | |

Property Information:

| | | | | | | | |
|------------------------------------|----------|---------|------|----------|------|-------|-------|
| Value of Stolen Property | Currency | Jewelry | Furs | Clothing | Auto | Misc. | Total |
| Value of Stolen Property Recovered | | | | | | | |

Automobile Information:

| 1 | Vehicle Code | Year | Make | Body Type | Model | Color | Registration | State | VIN |
|---|--------------|------|------|-----------|-------|-------|--------------|-------|-----|
| 2 | | | | | | | | | |
| 3 | | | | | | | | | |
| 4 | | | | | | | | | |

Narrative:

| | | | | | | | | | | | | |
|---------------------------|--------------|-----------------------------|--------|-------|-----|------|------|-----|------|------|--|---------------------|
| Officer of Record: | Date: | Other Reports Filed: | | | | | | | | | | Reviewed By: |
| PO Wesley Drinker 347 | 11/08/19 | MVA | Arrest | DV | DWI | DWIQ | Tow | SD | CI | TRO | | cantinori |
| | | SHA | Prop. | Video | UOF | Prst | Supp | Juv | Bias | Pris | | |



Teaneck Police Department

900 Teaneck Rd, Teaneck, NJ 07666

Phone: 201-837-2600 Fax: 201-837-1880 Mun. Code: 0260

Incident Report



Incident Details:

| | | | | | | | | | |
|-------------|---------------|---------------|---------------|---------------|-----------------------------------|---------------|---------------|-----|-----------|
| Case Number | Time Reported | Date Reported | Time Occurred | Date Occurred | Occurrence Between Date / Time of | Time Occurred | Date Occurred | 911 | Completed |
| 19-067623 | 09:44 | 12/12/19 | 09:44 | 12/12/19 | | | | X | X |

Incident Type:

Medical Emergency

Incident Location:

| | | |
|---------------------------------|-----------------|---------------------------------|
| Street # | Street Name | Intersection / Cross Street of: |
| 22 | W Englewood Ave | W Englewood Ave / Teaneck |
| Business / Common Location Name | | |

Contact Information: Victim, Suspect, Complainant, Witness, Driver, Arrest, Police, Minor, Contact, Other

| | | | | | | | | |
|---------|-----------------|----|--------|-----|-----|------------|------------|-----|
| Code | Contact Name #2 | MI | Suffix | Age | Sex | Race | DOB | SSN |
| Address | | | | | | Home Phone | Cell Phone | |
| Code | Contact Name #3 | MI | Suffix | Age | Sex | Race | DOB | SSN |
| Address | | | | | | Home Phone | Cell Phone | |
| Code | Contact Name #4 | MI | Suffix | Age | Sex | Race | DOB | SSN |
| Address | | | | | | Home Phone | Cell Phone | |

Property Information:

| | | | | | | | |
|------------------------------------|----------|---------|------|----------|------|-------|-------|
| Value of Stolen Property | Currency | Jewelry | Furs | Clothing | Auto | Misc. | Total |
| Value of Stolen Property Recovered | | | | | | | |

Automobile Information:

| 1 | Vehicle Code | Year | Make | Body Type | Model | Color | Registration | State | VIN |
|---|--------------|------|------|-----------|-------|-------|--------------|-------|-----|
| 2 | | | | | | | | | |
| 3 | | | | | | | | | |
| 4 | | | | | | | | | |

Narrative:

TVAC transporting one to Holy Name Hospital.

Officer of Record: PO Michael Apreda 355 **Date:** 12/12/19 **Other Reports Filed:** MVA Arrest DV DWI DWIQ Tow SD CI TRO **Reviewed By:** dalcott

| | | | | | | | | | | |
|-----------------------|----------|-----------|-------|-----|------|------|-----|------|------|---------|
| PO Michael Apreda 355 | 12/12/19 | SHA Prop. | Video | UOF | Prst | Supp | Juv | Bias | Pris | dalcott |
|-----------------------|----------|-----------|-------|-----|------|------|-----|------|------|---------|



Teaneck Police Department

900 Teaneck Rd, Teaneck, NJ 07666

Phone: 201-837-2600 Fax: 201-837-1880 Mun. Code: 0260

Incident Report



Incident Details:

| | | | | | | | | | |
|-------------|---------------|---------------|---------------|---------------|-----------------------------------|---------------|---------------|-----|-----------|
| Case Number | Time Reported | Date Reported | Time Occurred | Date Occurred | Occurrence Between Date / Time of | Time Occurred | Date Occurred | 911 | Completed |
| 20-021751 | 10:02 | 05/01/20 | 10:02 | 05/01/20 | | | | X | X |

Incident Type:

Medical Emergency

Incident Location:

| | | |
|---------------------------------|-----------------|---------------------------------|
| Street # | Street Name | Intersection / Cross Street of: |
| 22 | W Englewood Ave | W Englewood Ave / Teaneck |
| Business / Common Location Name | | |

Contact Information: Victim Suspect Complainant Witness Driver Arrest Passenger Missing Involved Other

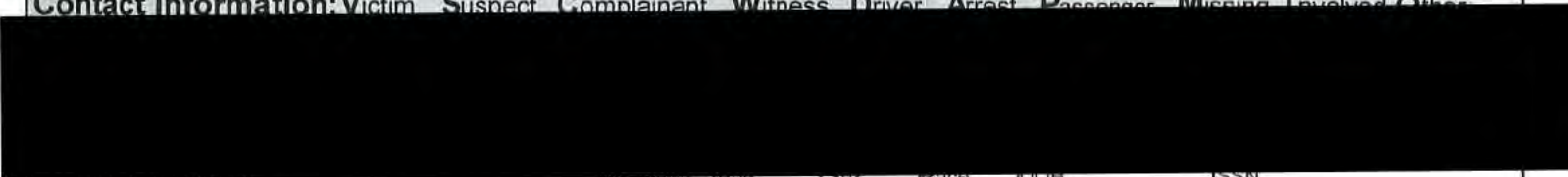

| | | | | | | | | |
|---------|-----------------|----|--------|-----|-----|------------|------------|-----|
| Code | Contact Name #1 | MI | Suffix | Age | Sex | Race | DOB | SSN |
| Address | | | | | | Home Phone | Cell Phone | |
| Code | Contact Name #3 | MI | Suffix | Age | Sex | Race | DOB | SSN |
| Address | | | | | | Home Phone | Cell Phone | |
| Code | Contact Name #4 | MI | Suffix | Age | Sex | Race | DOB | SSN |
| Address | | | | | | Home Phone | Cell Phone | |

Property Information:

| | | | | | | | |
|------------------------------------|----------|---------|------|----------|------|-------|-------|
| Value of Stolen Property | Currency | Jewelry | Furs | Clothing | Auto | Misc. | Total |
| Value of Stolen Property Recovered | | | | | | | |

Automobile Information:

| 1 | Vehicle Code | Year | Make | Body Type | Model | Color | Registration | State | VIN |
|---|--------------|------|------|-----------|-------|-------|--------------|-------|-----|
| 2 | | | | | | | | | |
| 3 | | | | | | | | | |
| 4 | | | | | | | | | |

Narrative:

On Friday, May 1, 2020, at 10:02 AM, the Teaneck Volunteer Ambulance #75 responded to 22 West Englewood Avenue on a report of a female individual suffering from back pain.

Upon arrival, they met with the injured party, [REDACTED]. The ambulance members assessed [REDACTED] and then transported her to Holy Name Medical Center for further medical treatment.

Police Officer: Constantinos Skoufas

Officer of Record: Date: Other Reports Filed: Reviewed By:

| | | | |
|-------------------------|----------|---|----------|
| PO Constantinos Skoufas | 05/01/20 | MVA Arrest DV DWI DWIQ Tow SD CI TRO | pforrest |
| | | SHA Prop. Video UOF Prst Supp Juv Bias Pris | |



Teaneck Police Department

900 Teaneck Rd, Teaneck, NJ 07666

Phone: 201-837-2600 Fax: 201-837-1880 Mun. Code: 0260

Incident Report



Incident Details:

| | | | | | | | | | |
|-------------|---------------|---------------|---------------|---------------|-----------------------------------|---------------|---------------|-----|-----------|
| Case Number | Time Reported | Date Reported | Time Occurred | Date Occurred | Occurrence Between Date / Time of | Time Occurred | Date Occurred | 911 | Completed |
| 20-031474 | 20:00 | 06/29/20 | 20:00 | 06/29/20 | | | | X | X |

Incident Type:

Medical Emergency

Incident Location:

| | | |
|---------------------------------|-----------------|---------------------------------|
| Street # | Street Name | Intersection / Cross Street of: |
| 22 | W Englewood Ave | W Englewood Ave / Teaneck |
| Business / Common Location Name | | |

Contact Information: Victim Suspect Complainant Witness Driver Arrest Passenger Missing Involved Other

| | | | | | | | | |
|---------|-----------------|----|--------|-----|-----|------------|------------|-----|
| Code | Contact Name #2 | MI | Suffix | Age | Sex | Race | DOB | SSN |
| Address | | | | | | Home Phone | Cell Phone | |
| Code | Contact Name #3 | MI | Suffix | Age | Sex | Race | DOB | SSN |
| Address | | | | | | Home Phone | Cell Phone | |
| Code | Contact Name #4 | MI | Suffix | Age | Sex | Race | DOB | SSN |
| Address | | | | | | Home Phone | Cell Phone | |

Property Information:

| | | | | | | | |
|------------------------------------|----------|---------|------|----------|------|-------|-------|
| Value of Stolen Property | Currency | Jewelry | Furs | Clothing | Auto | Misc. | Total |
| Value of Stolen Property Recovered | | | | | | | |

Automobile Information:

| 1 | Vehicle Code | Year | Make | Body Type | Model | Color | Registration | State | VIN |
|---|--------------|------|------|-----------|-------|-------|--------------|-------|-----|
| 2 | | | | | | | | | |
| 3 | | | | | | | | | |
| 4 | | | | | | | | | |

Narrative:

Officer of Record: Date: Other Reports Filed: Reviewed By:

| | | |
|---|--------------------------------------|---------|
| PO Brandon Graham 354 06/29/20 | MVA Arrest DV DWI DWIQ Tow SD CI TRO | gwright |
| SHA Prop. Video UOF Prst Supp Juv Bias Pris | | |



Teaneck Police Department

900 Teaneck Rd, Teaneck, NJ 07666

Phone: 201-837-2600 Fax: 201-837-1880 Mun. Code: 0260



Incident Report

| Incident Details: | | | Incident Location: | Disposition |
|-------------------|-------|----------|-----------------------------|------------------|
| Case Number | Time | Date | Address | Disposition |
| PD-17-030270 | 16:02 | 08/16/17 | 20 W ENGLEWOOD AVE, TEANECK | Report Completed |

Incident Type:

| | |
|--------------------------------|--|
| Impounded Or Abandoned Vehicle | |
|--------------------------------|--|

| Narrative | Officer | Approving Officer |
|-----------|---------|-------------------|
| | vsuar | |

On Wednesday August 16 2017 at approximately 4 02 p.m. while patrolling the Teaneck Road and West Englewood area I observed a black 2010 Nissan Altima parked in front of 20 West Englewood Avenue in a No Parking Any Time Zone. After conducting a query for the license plate I discovered that the vehicle s registration was expired on July 2017 7 2017 . I requested police headquarters to dispatched the duty town for the vehicle s impound. Degraw services arrived on scene and impounded the vehicle to their impound lot. I issued the registered owner [REDACTED] who arrived on scene the following summons E17 010428 in violation of Teaneck Township statute 36-12 No Parking Any Time and E17 010430 in violation of 39 3-4 Driving or Parking Unregistered Motor Vehicle. Mr. [REDACTED] was advised on how to go about retrieving his vehicle back. Submitted by P.O. V. Suárez 320



Teaneck Police Department

900 Teaneck Rd, Teaneck, NJ 07666

Phone: 201-837-2600 Fax: 201-837-1880 Mun. Code: 0260

Incident Report



| Incident Details: | | | | | | | | | |
|-------------------|---------------|---------------|---------------|---------------|-----------------------------------|---------------|---------------|-----|-----------|
| Case Number | Time Reported | Date Reported | Time Occurred | Date Occurred | Occurrence Between Date / Time of | Time Occurred | Date Occurred | 911 | Completed |
| 22-004733 | 01:12 | 01/25/22 | 01:12 | 01/25/22 | | | | X | X |

| Incident Type: | Incident Location: |
|--|---|
| Aggravated Assault - Strangulation (DV) Terroristic Threats 2C:12-3 Domestic Violence 2C:25-21 | Street # Street Name 20 W Englewood Ave Intersection / Cross Street of: W Englewood Ave / Teaneck Business / Common Location Name |

Contact Information: Victim Suspect Complainant Witness Driver Arrest Passenger Missing Involved Other

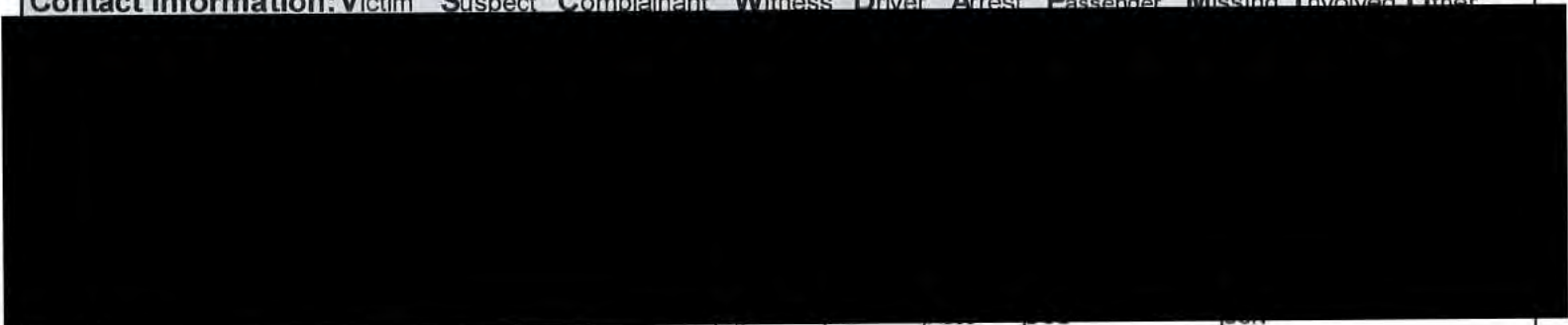

| | | | | | | | | | |
|---------|-----------------|----|--------|-----|-----|------------|-----|------------|--|
| Address | | | | | | Home Phone | | Cell Phone | |
| Code | Contact Name #4 | MI | Suffix | Age | Sex | Race | DOB | SSN | |
| Address | | | | | | Home Phone | | Cell Phone | |

| Property Information: | | | | | | | |
|------------------------------------|----------|---------|------|----------|------|-------|-------|
| Value of Stolen Property | Currency | Jewelry | Furs | Clothing | Auto | Misc. | Total |
| Value of Stolen Property Recovered | | | | | | | |

| Automobile Information: | | | | | | | | | |
|-------------------------|--------------|------|------|-----------|-------|-------|--------------|-------|-----|
| 1 | Vehicle Code | Year | Make | Body Type | Model | Color | Registration | State | VIN |
| 2 | | | | | | | | | |
| 3 | | | | | | | | | |
| 4 | | | | | | | | | |

Narrative:



| | | | |
|---------------------------|--------------|---|---------------------|
| Officer of Record: | Date: | Other Reports Filed: | Reviewed By: |
| PO Jorge Cano Vanegas | 01/25/22 | MVA Arrest 1 DV 1 DWI DWIQ Tow SD CI TRO SHA Prop. Video UOF Prst Supp 1 Juv Bias Pris 1 | gwright |



Teaneck Police Department

900 Teaneck Rd, Teaneck, NJ 07666

Phone: 201-837-2600 Fax: 201-837-1880 Mun. Code: 0260

Incident Report



Narrative Continued (Page 2)

Case Number

22-004733

Officer of Record:

Date:

PO Jorge Cano Vanegas 348

01/25/22



Teaneck Police Department

900 Teaneck Rd, Teaneck, NJ 07666

Phone: 201-837-2600 Fax: 201-837-1880 Mun. Code: 0260

Incident Report



Narrative Continued (Page 3)

Case Number

22-004733

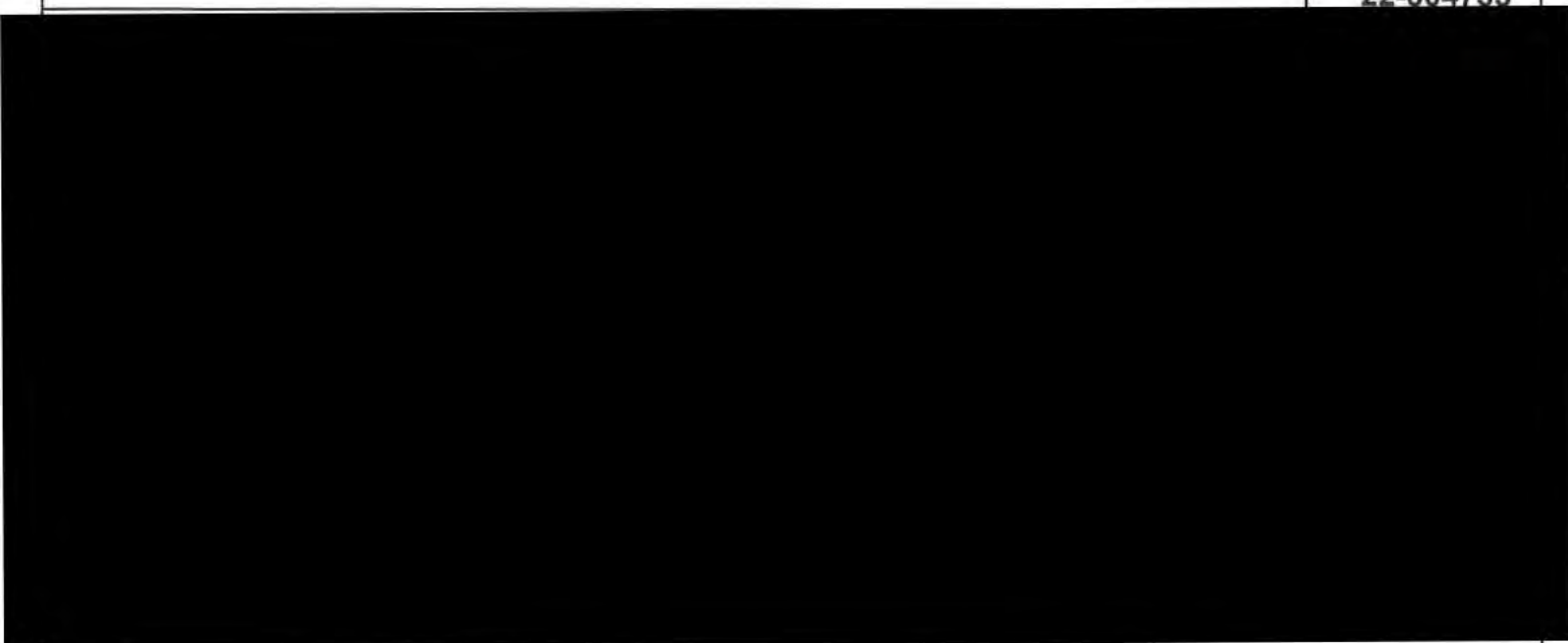

Officer of Record:

Date:

PO Jorge Cano Vanegas 348

01/25/22



Teaneck Police Department

900 Teaneck Rd, Teaneck, NJ 07666

Phone: 201-837-2600 Fax: 201-837-1880 Mun. Code: 0260

Incident Report



Incident Details:

| | | | | | | | | | |
|-------------|---------------|---------------|---------------|---------------|-----------------------------------|---------------|---------------|-----|-----------|
| Case Number | Time Reported | Date Reported | Time Occurred | Date Occurred | Occurrence Between Date / Time of | Time Occurred | Date Occurred | 911 | Completed |
| 22-031902 | 12:31 | 06/05/22 | 12:31 | 06/05/22 | | | | | X |

| | |
|-----------------------|---|
| Incident Type: | Incident Location: |
| Parking Offense | Street # Street Name 20 W Englewood Ave Intersection / Cross Street of: W Englewood Ave / Teaneck Business / Common Location Name |

Contact Information: Victim Suspect Complainant Witness Driver Arrest Passenger Missing Involved Other

| Code | Contact Name #1 | MI | Suffix | Age | Sex | Race | DOB | SSN |
|---------|-----------------|----|--------|-----|-----|------------|------------|-----|
| Address | | | | | | | | |
| | | | | | | Home Phone | Cell Phone | |
| Code | Contact Name #2 | MI | Suffix | Age | Sex | Race | DOB | SSN |
| Address | | | | | | | | |
| | | | | | | Home Phone | Cell Phone | |
| Code | Contact Name #3 | MI | Suffix | Age | Sex | Race | DOB | SSN |
| Address | | | | | | | | |
| | | | | | | Home Phone | Cell Phone | |
| Code | Contact Name #4 | MI | Suffix | Age | Sex | Race | DOB | SSN |
| Address | | | | | | | | |
| | | | | | | Home Phone | Cell Phone | |

Property Information:

| | | | | | | | |
|------------------------------------|----------|---------|------|----------|------|-------|-------|
| Value of Stolen Property | Currency | Jewelry | Furs | Clothing | Auto | Misc. | Total |
| Value of Stolen Property Recovered | | | | | | | |

Automobile Information:

| 1 | Vehicle Code | Year | Make | Body Type | Model | Color | Registration | State | VIN |
|---|--------------|------|------|-----------|-------|-------|--------------|-------|-----|
| 2 | | | | | | | | | |
| 3 | | | | | | | | | |
| 4 | | | | | | | | | |

Narrative:

no report

Officer of Record: Date: Other Reports Filed: Reviewed By:

| | | | |
|------------------------|----------|---|---------|
| PO Rafael Vallejos 362 | 06/05/22 | MVA Arrest DV DWI DWIQ Tow SD CI TRO SHA Prop. Video UOF Prst Supp Juv Bias Pris | papreda |
|------------------------|----------|---|---------|



Teaneck Police Department

900 Teaneck Rd, Teaneck, NJ 07666

Phone: 201-837-2600 Fax: 201-837-1880 Mun. Code: 0260

CAD Report



| CAD # | Case # | Date | Time of Call | Dispatched | Arrived | Cleared | 911 |
|-----------|--------|----------|--------------|------------|---------|---------|-----|
| 22-031902 | 22 | 06/05/22 | 12:31 | 12:39 | 12:39 | 12:41 | |

| Reg. | St. | Race Code | Citations | Warning |
|------|-----|-----------|-----------|---------|
| | | | | |

| Incident Type | Business / School / Location Name |
|-----------------|-----------------------------------|
| Parking Offense | |

| Location: | | | | |
|-----------|-----------------|-------|-------------------------------------|------|
| Street # | Street Name | Apt.# | Cross Street / Nearest Intersection | Zone |
| 20 | W Englewood Ave | | W Englewood Ave / Teaneck Road | 2S |

| Contact (Lastname, Firstname) | Contact Address | Contact Phone |
|-------------------------------|-----------------|---------------|
| | | |

| Notes | Time | Entered By |
|--|----------------|------------|
| black pickup truck blocking driveway | 06/05/22 12:32 | jnogueras |
| vehicle moved..no summons issued | 06/05/22 12:41 | jnogueras |
| report made in error..no report needed | 06/05/22 13:28 | lthomas |

| Officer(s) | Car(s) | Date | Dispatched | Arrived | Cleared | Time on Scene |
|------------------------|--------|----------|------------|---------|---------|---------------|
| PO Rafael Vallejos 362 | 28 | 6/5/2022 | 12:39 | 12:39 | 12:41 | 00:01 |

| Average Response Time for this Call: | Dispatched By: | Disposition: |
|--------------------------------------|----------------|--------------|
| 00:00:02 | jnogueras | Cleared |



Teaneck Police Department

900 Teaneck Rd, Teaneck, NJ 07666

Phone: 201-837-2600 Fax: 201-837-1880 Mun. Code: 0260

CAD Report



| Incident Details: | | | Incident Location: | | Disposition |
|-------------------|-------|----------|-----------------------------|--|------------------|
| Case Number | Time | Date | Address | | Disposition |
| PD-18-017827 | 12:17 | 05/06/18 | 18 W ENGLEWOOD AVE, TEANECK | | Report Completed |

| Incident Type: | | | | Dispatched By | | | | Created By | |
|----------------|---------|-----------------|---------|---------------|---------|--------------|---------|------------|--|
| Simple Assault | | | | Bmaye | | | | Bmaye | |
| Unit | Officer | Unit | Officer | Unit | Officer | Unit | Officer | | |
| 350 | Arami | 330 | Papre | 299 | Pwest | 266 | Wcroo | | |
| Time Received | | Time Dispatched | | Time Arrived | | Time Cleared | | | |
| 1217 | | 1218 | | 1218 | | 1219 | | | |

| Contact Information: | | | | | | | |
|----------------------|--------------|---------|--|-----|-----|------|-------|
| Role | Contact Name | Address | | DOB | Sex | Race | Phone |
| | | | | | | | |

| Auto Information: | | | | | | |
|-------------------|-------|------|-------|-------|------|-------------------|
| Registration | State | Make | Model | Color | Year | VIN |
| 027784 | NJ | TOYT | SNA | WHI | 2017 | 5TDKZ3DC5HS814061 |

| Summonses: | | | | |
|---------------|------|-----------|------|---------|
| Ticket Number | Date | Violation | Name | Officer |
| | | | | |
| | | | | |
| | | | | |
| | | | | |

Narrative:
 Input bmaye 05 06 2018 12 20 26 Edited bmaye 05 06 2018 12 20 26 ENGLEWOOD ADVISING A FIGHT 6 MALES Input bmaye 05 06 2018 12 20 33 Edited bmaye 05 06 2018 12 20 33 REQ FOR AN AMBULANCE Input bmaye 05 06 2018 12 25 44 Edited bmaye 05 06 2018 12 25 44 NJ S42FHZ Input bmaye 05 06 2018 12 25 52 Edited bmaye 05 06 2018 12 25 52 NJ REG 027784 Input vsuar 05 06 2018 12 27 03 Edited vsuar 05 06 2018 12 27 03 [REDACTED] 11 06 [REDACTED] Input bmaye 05 06 2018 12 33 47 Edited bmaye 05 06 2018 12 33 47 REFUSED MEDICAL AID



Teaneck Police Department

900 Teaneck Rd, Teaneck, NJ 07666

Phone: 201-837-2600 Fax: 201-837-1880 Mun. Code: 0260



Incident Report

| Incident Details: | | | Incident Location: | | Disposition |
|-------------------|-------|----------|-----------------------------|-------------------|------------------|
| Case Number | Time | Date | Address | | Disposition |
| PD-18-017827 | 12:17 | 05/06/18 | 18 W ENGLEWOOD AVE, TEANECK | | Report Completed |
| Incident Type: | | | | | |
| Simple Assault | | | | | |
| Narrative | | Officer | | Approving Officer | |
| | | arami | | pforr | |

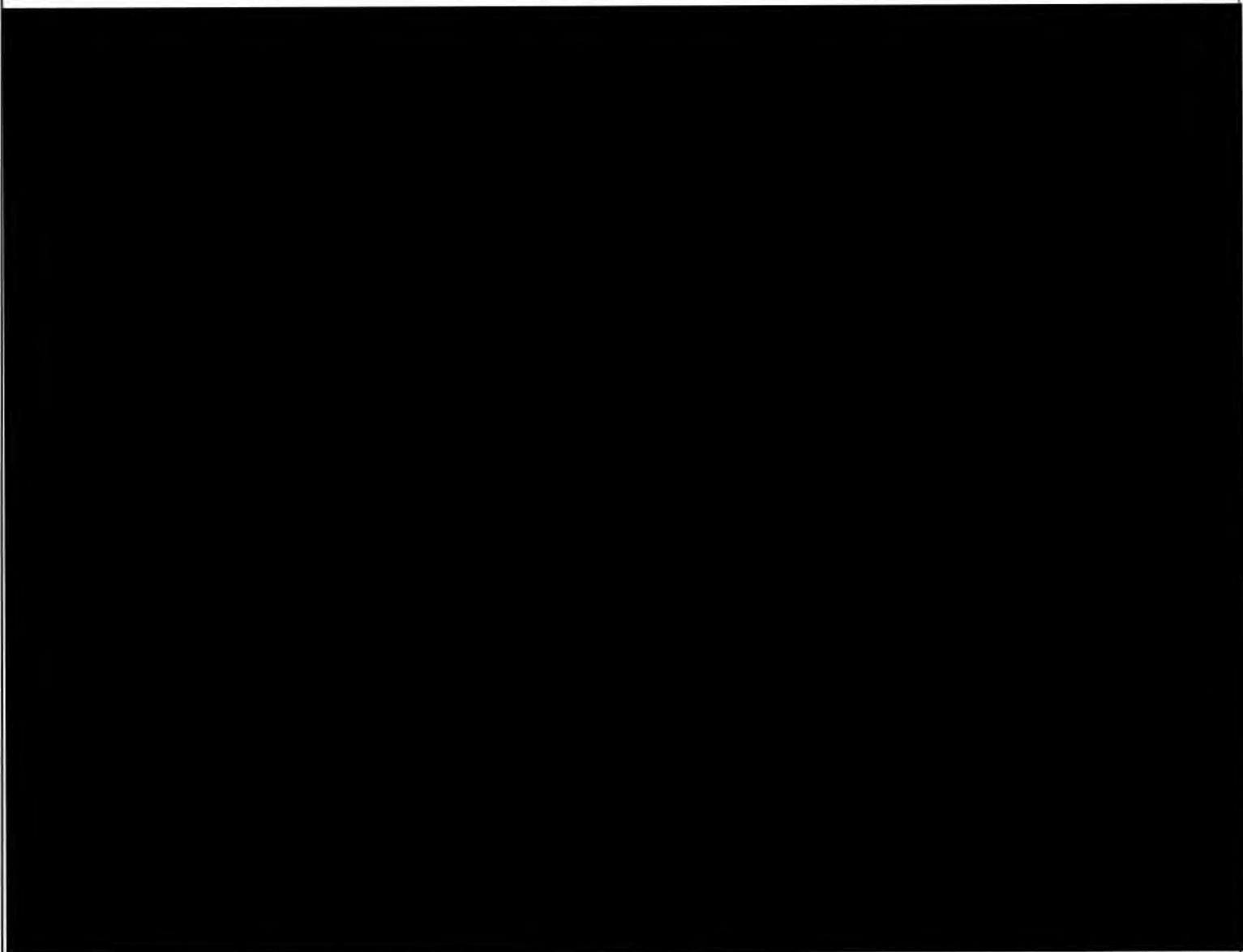



Teaneck Police Department

900 Teaneck Rd, Teaneck, NJ 07666

Phone: 201-837-2600 Fax: 201-837-1880 Mun. Code: 0260

Incident Report



Incident Details:

| | | | | | | | | | |
|-------------|---------------|---------------|---------------|---------------|-----------------------------------|---------------|---------------|-----|-----------|
| Case Number | Time Reported | Date Reported | Time Occurred | Date Occurred | Occurrence Between Date / Time of | Time Occurred | Date Occurred | 911 | Completed |
| 18-021935 | 09:57 | 05/26/18 | 09:57 | 05/26/18 | | | | | X |

| | |
|-----------------------|--|
| Incident Type: | Incident Location: |
| Medical Emergency | Street # Street Name 18 W Englewood Ave Intersection / Cross Street of: Business / Common Location Name |

Contact Information: Victim Suspect Complainant Witness Driver Arrest Passenger Missing Involved Other



| | | |
|---|------------|------------|
| Address | Home Phone | Cell Phone |
| Code Contact Name #3 MI Suffix Age Sex Race DOB SSN | | |
| Address | Home Phone | Cell Phone |
| Code Contact Name #4 MI Suffix Age Sex Race DOB SSN | | |
| Address | Home Phone | Cell Phone |

Property Information:

| | | | | | | | |
|------------------------------------|----------|---------|------|----------|------|-------|-------|
| Value of Stolen Property | Currency | Jewelry | Furs | Clothing | Auto | Misc. | Total |
| Value of Stolen Property Recovered | | | | | | | |

Automobile Information:

| 1 | Vehicle Code | Year | Make | Body Type | Model | Color | Registration | State | VIN |
|---|--------------|------|------|-----------|-------|-------|--------------|-------|-----|
| 2 | | | | | | | | | |
| 3 | | | | | | | | | |
| 4 | | | | | | | | | |

Narrative:

TVAC ambulance 72 was transported to Holy Name Hospital.

Officer of Record: **Date:** **Other Reports Filed:** **Reviewed By:**

| | | |
|-------------------------------|---|----------|
| PO Raymond Byrne 234 05/26/18 | MVA Arrest DV DWI DWIQ Tow SD CI TRO SHA Prop. Video UOF Prst Supp Juv Bias Pris | rmehnert |
|-------------------------------|---|----------|



Teaneck Police Department

900 Teaneck Rd, Teaneck, NJ 07666

Phone: 201-837-2600 Fax: 201-837-1880 Mun. Code: 0260

Incident Report



| Incident Details: | | | | | | | | | |
|-------------------|---------------|---------------|---------------|---------------|-----------------------------------|---------------|---------------|-----|-----------|
| Case Number | Time Reported | Date Reported | Time Occurred | Date Occurred | Occurrence Between Date / Time of | Time Occurred | Date Occurred | 911 | Completed |
| 18-023556 | 22:53 | 06/03/18 | | | | | | | X |

| Incident Type: | | | Incident Location: | | |
|---------------------------------|--|--|--------------------|-----------------|---------------------------------|
| Medical Emergency | | | Street # | Street Name | Intersection / Cross Street of: |
| | | | 18 | W Englewood Ave | W Englewood Ave / Teaneck |
| Business / Common Location Name | | | | | |

Contact Information: Victim Suspect Complainant Witness Driver Arrest Passenger Missing Involved Other

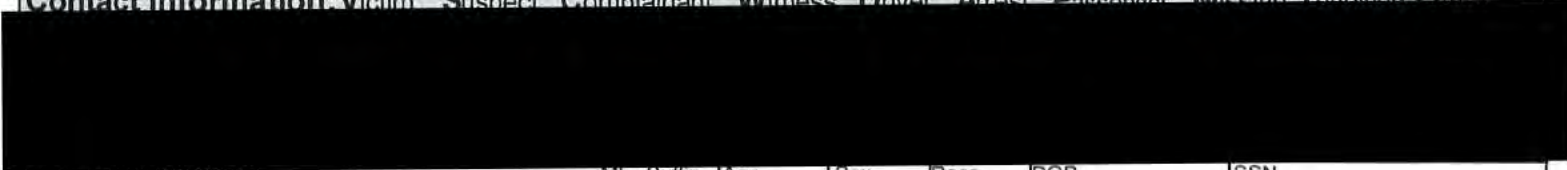

| | | | | | | | | |
|---------|-----------------|----|--------|-----|-----|------------|------------|-----|
| Code | Contact Name #2 | MI | Suffix | Age | Sex | Race | DOB | SSN |
| Address | | | | | | Home Phone | Cell Phone | |
| Code | Contact Name #3 | MI | Suffix | Age | Sex | Race | DOB | SSN |
| Address | | | | | | Home Phone | Cell Phone | |
| Code | Contact Name #4 | MI | Suffix | Age | Sex | Race | DOB | SSN |
| Address | | | | | | Home Phone | Cell Phone | |

| Property Information: | | | | | | | |
|------------------------------------|----------|---------|------|----------|------|-------|-------|
| Value of Stolen Property | Currency | Jewelry | Furs | Clothing | Auto | Misc. | Total |
| Value of Stolen Property Recovered | | | | | | | |

| Automobile Information: | | | | | | | | | |
|-------------------------|--------------|------|------|-----------|-------|-------|--------------|-------|-----|
| 1 | Vehicle Code | Year | Make | Body Type | Model | Color | Registration | State | VIN |
| 2 | | | | | | | | | |
| 3 | | | | | | | | | |
| 4 | | | | | | | | | |

Narrative:

| | | | |
|---------------------------|--------------|---|---------------------|
| Officer of Record: | Date: | Other Reports Filed: | Reviewed By: |
| PO Thomas Caruso 270 | 06/03/18 | MVA Arrest DV DWI DWIQ Tow SD CI TRO SHA Prop. Video UOF Prst Supp Juv Bias Pris | jwilliams |



Teaneck Police Department

900 Teaneck Rd, Teaneck, NJ 07666

Phone: 201-837-2600 Fax: 201-837-1880 Mun. Code: 0260

Incident Report



Incident Details:

| | | | | | | | | | |
|-------------|---------------|---------------|---------------|---------------|-----------------------------------|---------------|---------------|-----|-----------|
| Case Number | Time Reported | Date Reported | Time Occurred | Date Occurred | Occurrence Between Date / Time of | Time Occurred | Date Occurred | 911 | Completed |
| 18-023910 | 18:41 | 06/05/18 | 18:41 | 06/05/18 | | | | X | X |

| | |
|-----------------------|--|
| Incident Type: | Incident Location: |
| Medical Emergency | Street # Street Name 18 W Englewood Ave Intersection / Cross Street of: Business / Common Location Name |

Contact Information: Victim Suspect Complainant Witness Driver Arrest Passenger Missing Involved Other



| | | | | | | | | |
|---------|-----------------|----|--------|-----|-----|------------|------------|-----|
| Code | Contact Name #2 | MI | Suffix | Age | Sex | Race | DOB | SSN |
| Address | | | | | | Home Phone | Cell Phone | |
| Code | Contact Name #3 | MI | Suffix | Age | Sex | Race | DOB | SSN |
| Address | | | | | | Home Phone | Cell Phone | |
| Code | Contact Name #4 | MI | Suffix | Age | Sex | Race | DOB | SSN |
| Address | | | | | | Home Phone | Cell Phone | |

Property Information:

| | | | | | | | |
|------------------------------------|----------|---------|------|----------|------|-------|-------|
| Value of Stolen Property | Currency | Jewelry | Furs | Clothing | Auto | Misc. | Total |
| Value of Stolen Property Recovered | | | | | | | |

Automobile Information:

| 1 | Vehicle Code | Year | Make | Body Type | Model | Color | Registration | State | VIN |
|---|--------------|------|------|-----------|-------|-------|--------------|-------|-----|
| 2 | | | | | | | | | |
| 3 | | | | | | | | | |
| 4 | | | | | | | | | |

Narrative:

1 transported to HHH via tvac 75

Officer of Record: Date: Other Reports Filed: Reviewed By:

| | | | |
|------------------------|----------|---|----------|
| PO Daniel Antinori 351 | 06/05/18 | MVA Arrest DV DWI DWIQ Tow SD CI TRO SHA Prop. Video UOF Prst Supp Juv Bias Pris | rmehnert |
|------------------------|----------|---|----------|



Teaneck Police Department

900 Teaneck Rd, Teaneck, NJ 07666

Phone: 201-837-2600 Fax: 201-837-1880 Mun. Code: 0260

Incident Report



Incident Details:

| | | | | | | | | | |
|-------------|---------------|---------------|---------------|---------------|-----------------------------------|---------------|---------------|-----|-----------|
| Case Number | Time Reported | Date Reported | Time Occurred | Date Occurred | Occurrence Between Date / Time of | Time Occurred | Date Occurred | 911 | Completed |
| 18-025421 | 09:05 | 06/12/18 | 09:05 | 06/12/18 | | | | X | X |

Incident Type:

Medical Emergency

Incident Location:

Street # Street Name Intersection / Cross Street of:
 18 W Englewood Ave W Englewood Ave / Teaneck
 Business / Common Location Name

Contact Information: Victim Suspect Complainant Witness Driver Arrest Recipient Missing Injured Other

| | | | | | | | | | |
|---------|-----------------|----|--------|-----|-----|------------|-----|------------|--|
| Address | | | | | | Home Phone | | Cell Phone | |
| Code | Contact Name #3 | MI | Suffix | Age | Sex | Race | DOB | SSN | |
| Address | | | | | | Home Phone | | Cell Phone | |
| Code | Contact Name #4 | MI | Suffix | Age | Sex | Race | DOB | SSN | |
| Address | | | | | | Home Phone | | Cell Phone | |

Property Information:

| | | | | | | | |
|------------------------------------|----------|---------|------|----------|------|-------|-------|
| Value of Stolen Property | Currency | Jewelry | Furs | Clothing | Auto | Misc. | Total |
| Value of Stolen Property Recovered | | | | | | | |

Automobile Information:

| 1 | Vehicle Code | Year | Make | Body Type | Model | Color | Registration | State | VIN |
|---|--------------|------|------|-----------|-------|-------|--------------|-------|-----|
| 2 | | | | | | | | | |
| 3 | | | | | | | | | |
| 4 | | | | | | | | | |

Narrative:

One transported to Englewood Hospital.

Officer of Record: Date: Other Reports Filed: Reviewed By:

| | | | |
|----------------------|----------|---|--------|
| PO Philip Apreda 330 | 06/12/18 | MVA Arrest DV DWI DWIQ Tow SD CI TRO SHA Prop. Video UOF Prst Supp Juv Bias Pris | ttully |
|----------------------|----------|---|--------|



Teaneck Police Department

900 Teaneck Rd, Teaneck, NJ 07666

Phone: 201-837-2600 Fax: 201-837-1880 Mun. Code: 0260

Incident Report



Incident Details:

| | | | | | | | | | |
|-------------|---------------|---------------|---------------|---------------|-----------------------------------|---------------|---------------|-----|-----------|
| Case Number | Time Reported | Date Reported | Time Occurred | Date Occurred | Occurrence Between Date / Time of | Time Occurred | Date Occurred | 911 | Completed |
| 18-043915 | 16:58 | 09/11/18 | 16:58 | 09/11/18 | | | | X | X |

Incident Type:

Medical Emergency

Incident Location:

Street # Street Name Intersection / Cross Street of:
 18 W Englewood Ave W Englewood Ave / Teaneck
 Business / Common Location Name

Contact Information: Victim Suspect Complainant Witness Driver Arrest Passenger Missing Involved Other

| | | | | | | | | | |
|---------|-----------------|----|--------|-----|-----|------------|-----|------------|--|
| Address | | | | | | Home Phone | | Cell Phone | |
| Code | Contact Name #3 | MI | Suffix | Age | Sex | Race | DOB | SSN | |
| Address | | | | | | Home Phone | | Cell Phone | |
| Code | Contact Name #4 | MI | Suffix | Age | Sex | Race | DOB | SSN | |
| Address | | | | | | Home Phone | | Cell Phone | |

Property Information:

| | | | | | | | |
|------------------------------------|----------|---------|------|----------|------|-------|-------|
| Value of Stolen Property | Currency | Jewelry | Furs | Clothing | Auto | Misc. | Total |
| Value of Stolen Property Recovered | | | | | | | |

Automobile Information:

| 1 | Vehicle Code | Year | Make | Body Type | Model | Color | Registration | State | VIN |
|---|--------------|------|------|-----------|-------|-------|--------------|-------|-----|
| 2 | | | | | | | | | |
| 3 | | | | | | | | | |
| 4 | | | | | | | | | |

Narrative:

[Redacted] Transported to Englewood Hospital by TVAC.

Officer of Record: Date: Other Reports Filed: Reviewed By:

| | | | |
|---------------------|----------|---|---------|
| PO Kevin Florio 349 | 09/11/18 | MVA Arrest DV DWI DWIQ Tow SD CI TRO SHA Prop. Video UOF Prst Supp Juv Bias Pris | dalcott |
|---------------------|----------|---|---------|



Teaneck Police Department

900 Teaneck Rd, Teaneck, NJ 07666

Phone: 201-837-2600 Fax: 201-837-1880 Mun. Code: 0260

Incident Report



Incident Details:

| | | | | | | | | | |
|-------------|---------------|---------------|---------------|---------------|-----------------------------------|---------------|---------------|-----|-----------|
| Case Number | Time Reported | Date Reported | Time Occurred | Date Occurred | Occurrence Between Date / Time of | Time Occurred | Date Occurred | 911 | Completed |
| 18-062775 | 18:31 | 12/19/18 | 18:31 | 12/19/18 | | | | X | X |

Incident Type:

Medical Emergency

Incident Location:

Street # Street Name Intersection / Cross Street of:
 18 W Englewood Ave W Englewood Ave / Teaneck
 Business / Common Location Name

| | | | | | | | | |
|---------|-----------------|----|--------|-----|-----|------------|------------|-----|
| Code | Contact Name #2 | MI | Suffix | Age | Sex | Race | DOB | SSN |
| Address | | | | | | Home Phone | Cell Phone | |
| Code | Contact Name #3 | MI | Suffix | Age | Sex | Race | DOB | SSN |
| Address | | | | | | Home Phone | Cell Phone | |
| Code | Contact Name #4 | MI | Suffix | Age | Sex | Race | DOB | SSN |
| Address | | | | | | Home Phone | Cell Phone | |

Property Information:

| | | | | | | | |
|------------------------------------|----------|---------|------|----------|------|-------|-------|
| Value of Stolen Property | Currency | Jewelry | Furs | Clothing | Auto | Misc. | Total |
| Value of Stolen Property Recovered | | | | | | | |

Automobile Information:

| 1 | Vehicle Code | Year | Make | Body Type | Model | Color | Registration | State | VIN |
|---|--------------|------|------|-----------|-------|-------|--------------|-------|-----|
| 2 | | | | | | | | | |
| 3 | | | | | | | | | |
| 4 | | | | | | | | | |

Narrative:

One transported to Holy Name Hospital.

Officer of Record:

Date:

Other Reports Filed:

Reviewed By:

| | | | | |
|----------------------|----------|--------------------------------------|---|--------|
| PO Philip Apreda 330 | 12/19/18 | MVA Arrest DV DWI DWIQ Tow SD CI TRO | SHA Prop. Video UOF Prst Supp Juv Bias Pris | ttully |
|----------------------|----------|--------------------------------------|---|--------|



Teaneck Police Department

900 Teaneck Rd, Teaneck, NJ 07666

Phone: 201-837-2600 Fax: 201-837-1880 Mun. Code: 0260

Incident Report



| Incident Details: | | | | | | | | | |
|-------------------|---------------|---------------|---------------|---------------|-----------------------------------|---------------|---------------|-----|-----------|
| Case Number | Time Reported | Date Reported | Time Occurred | Date Occurred | Occurrence Between Date / Time of | Time Occurred | Date Occurred | 911 | Completed |
| 19-012534 | 10:13 | 03/05/19 | 10:13 | 03/05/19 | | | | | X |

| Incident Type: | Incident Location: |
|-------------------|---|
| Medical Emergency | Street # Street Name 18 W Englewood Ave Intersection / Cross Street of: W Englewood Ave / Teaneck Business / Common Location Name |



| | | | | | | | | | | | |
|------|-----------------|----|--------|-----|-----|------|-----|-----|---------|------------|------------|
| Code | Contact Name #1 | MI | Suffix | Age | Sex | Race | DOB | SSN | Address | Home Phone | Cell Phone |
| Code | Contact Name #3 | MI | Suffix | Age | Sex | Race | DOB | SSN | Address | Home Phone | Cell Phone |
| Code | Contact Name #4 | MI | Suffix | Age | Sex | Race | DOB | SSN | Address | Home Phone | Cell Phone |

| Property Information: | | | | | | | |
|------------------------------------|----------|---------|------|----------|------|-------|-------|
| Value of Stolen Property | Currency | Jewelry | Furs | Clothing | Auto | Misc. | Total |
| Value of Stolen Property Recovered | | | | | | | |

| Automobile Information: | | | | | | | | | |
|-------------------------|--------------|------|------|-----------|-------|-------|--------------|-------|-----|
| 1 | Vehicle Code | Year | Make | Body Type | Model | Color | Registration | State | VIN |
| 2 | | | | | | | | | |
| 3 | | | | | | | | | |
| 4 | | | | | | | | | |

Narrative:
1 to Holy Name

| Officer of Record: | Date: | Other Reports Filed: | Reviewed By: |
|-----------------------|----------|---|--------------|
| PO Steven Batista 325 | 03/05/19 | MVA Arrest DV DWI DWIQ Tow SD CI TRO SHA Prop. Video UOF Prst Supp Juv Bias Pris | wcroonquist |



Teaneck Police Department

900 Teaneck Rd, Teaneck, NJ 07666

Phone: 201-837-2600 Fax: 201-837-1880 Mun. Code: 0260

Incident Report



Incident Details:

| | | | | | | | | | |
|-------------|---------------|---------------|---------------|---------------|-----------------------------------|---------------|---------------|-----|-----------|
| Case Number | Time Reported | Date Reported | Time Occurred | Date Occurred | Occurrence Between Date / Time of | Time Occurred | Date Occurred | 911 | Completed |
| 19-015064 | 14:41 | 03/18/19 | 14:41 | 03/18/19 | | | | X | X |

Incident Type:

Medical Emergency

Incident Location:

| | | |
|---------------------------------|-----------------|---------------------------------|
| Street # | Street Name | Intersection / Cross Street of: |
| 18 | W Englewood Ave | W Englewood Ave / Teaneck |
| Business / Common Location Name | | |



| | | | | | | | | |
|--------------------------|-----------------|----|--------|-----|-----|------------|-----|--------------|
| 18 West Englewood Avenue | | | | | | | | SSN-555-5556 |
| Code | Contact Name #3 | MI | Suffix | Age | Sex | Race | DOB | SSN |
| Address | | | | | | Home Phone | | Cell Phone |
| Code | Contact Name #4 | MI | Suffix | Age | Sex | Race | DOB | SSN |
| Address | | | | | | Home Phone | | Cell Phone |

Property Information:

| | | | | | | | |
|------------------------------------|----------|---------|------|----------|------|-------|-------|
| Value of Stolen Property | Currency | Jewelry | Furs | Clothing | Auto | Misc. | Total |
| Value of Stolen Property Recovered | | | | | | | |

Automobile Information:

| 1 | Vehicle Code | Year | Make | Body Type | Model | Color | Registration | State | VIN |
|---|--------------|------|------|-----------|-------|-------|--------------|-------|-----|
| 2 | | | | | | | | | |
| 3 | | | | | | | | | |
| 4 | | | | | | | | | |

Name: [Redacted]
 BO [Redacted] and requested transport to Englewood Hospital.

Officer of Record:

Date:

Other Reports Filed:

Reviewed By:

| | | | |
|----------------------|----------|---|----------|
| PO Patrick Haase 341 | 03/18/19 | MVA Arrest DV DWI DWIQ Tow SD CI TRO SHA Prop. Video UOF Prst Supp Juv Bias Pris | pforrest |
|----------------------|----------|---|----------|



Teaneck Police Department

900 Teaneck Rd, Teaneck, NJ 07666

Phone: 201-837-2600 Fax: 201-837-1880 Mun. Code: 0260

Incident Report



Incident Details:

| | | | | | | | | | |
|-------------|---------------|---------------|---------------|---------------|-----------------------------------|---------------|---------------|-----|-----------|
| Case Number | Time Reported | Date Reported | Time Occurred | Date Occurred | Occurrence Between Date / Time of | Time Occurred | Date Occurred | 911 | Completed |
| 19-028902 | 17:09 | 05/28/19 | 17:09 | 05/28/19 | | | | | X |

Incident Type:

Medical Emergency

Incident Location:

| | | |
|---------------------------------|-----------------|---------------------------------|
| Street # | Street Name | Intersection / Cross Street of: |
| 18 | W Englewood Ave | W Englewood Ave / Teaneck |
| Business / Common Location Name | | |

Contact Information: Victim Support Complainant Witness Driver Arrest Recipient Missing Involved Other

| | | | | | | | | | |
|---------|-----------------|----|--------|-----|-----|------------|-----|------------|--|
| Address | | | | | | Home Phone | | Cell Phone | |
| Code | Contact Name #3 | MI | Suffix | Age | Sex | Race | DOB | SSN | |
| Address | | | | | | Home Phone | | Cell Phone | |
| Code | Contact Name #4 | MI | Suffix | Age | Sex | Race | DOB | SSN | |
| Address | | | | | | Home Phone | | Cell Phone | |

Property Information:

| | | | | | | | |
|------------------------------------|----------|---------|------|----------|------|-------|-------|
| Value of Stolen Property | Currency | Jewelry | Furs | Clothing | Auto | Misc. | Total |
| Value of Stolen Property Recovered | | | | | | | |

Automobile Information:

| 1 | Vehicle Code | Year | Make | Body Type | Model | Color | Registration | State | VIN |
|---|--------------|------|------|-----------|-------|-------|--------------|-------|-----|
| 2 | | | | | | | | | |
| 3 | | | | | | | | | |
| 4 | | | | | | | | | |

Narrative:

1 to Holy Name Hospital

Officer of Record: Date: Other Reports Filed: Reviewed By:

| | | | |
|---------------------|----------|---|--------|
| PO Zachary Reed 352 | 05/28/19 | MVA Arrest DV DWI DWIQ Tow SD CI TRO SHA Prop. Video UOF Prst Supp Juv Bias Pris | ttully |
|---------------------|----------|---|--------|



Teaneck Police Department

900 Teaneck Rd, Teaneck, NJ 07666

Phone: 201-837-2600 Fax: 201-837-1880 Mun. Code: 0260

Incident Report



Incident Details:

| | | | | | | | | | |
|-------------|---------------|---------------|---------------|---------------|-----------------------------------|---------------|---------------|-----|-----------|
| Case Number | Time Reported | Date Reported | Time Occurred | Date Occurred | Occurrence Between Date / Time of | Time Occurred | Date Occurred | 911 | Completed |
| 19-037628 | 23:58 | 07/11/19 | 23:58 | 07/12/19 | | | | | X |

Incident Type:

Medical Emergency

Incident Location:

| | | |
|---------------------------------|-----------------|---------------------------------|
| Street # | Street Name | Intersection / Cross Street of: |
| 18 | W Englewood Ave | W Englewood Ave / Teaneck |
| Business / Common Location Name | | |

Contact Information: Victim, Suspect, Complainant, Witness, Driver, Arrest, Police Officer, Officer #

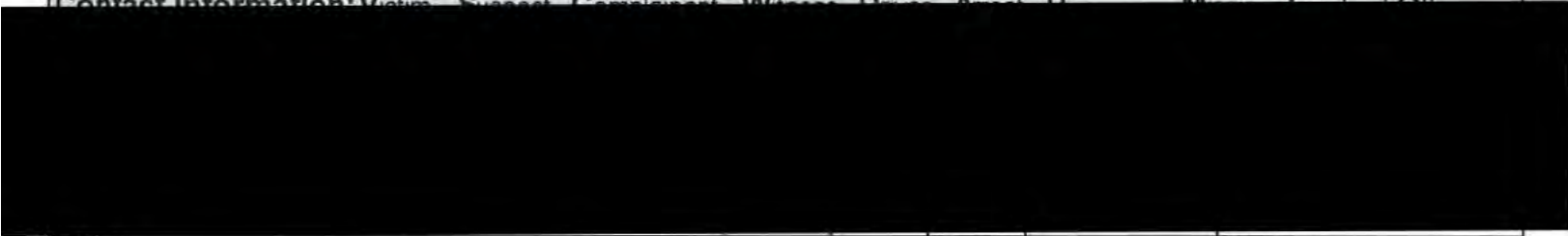

| | | | | | | | | | |
|---------|-----------------|----|--------|-----|------------|------|-----|------------|--|
| Address | | | | | Home Phone | | | Cell Phone | |
| Code | Contact Name #3 | MI | Suffix | Age | Sex | Race | DOB | SSN | |
| Address | | | | | Home Phone | | | Cell Phone | |
| Code | Contact Name #4 | MI | Suffix | Age | Sex | Race | DOB | SSN | |
| Address | | | | | Home Phone | | | Cell Phone | |

Property Information:

| | | | | | | | |
|------------------------------------|----------|---------|------|----------|------|-------|-------|
| Value of Stolen Property | Currency | Jewelry | Furs | Clothing | Auto | Misc. | Total |
| Value of Stolen Property Recovered | | | | | | | |

Automobile Information:

| 1 | Vehicle Code | Year | Make | Body Type | Model | Color | Registration | State | VIN |
|---|--------------|------|------|-----------|-------|-------|--------------|-------|-----|
| 2 | | | | | | | | | |
| 3 | | | | | | | | | |
| 4 | | | | | | | | | |

Narrative:



Police Officer James M. Hoover #339

Officer of Record: Date: Other Reports Filed: Reviewed By:

| | | | |
|---------------------|----------|---|---------|
| PO James Hoover 339 | 07/11/19 | MVA Arrest DV DWI DWIQ Tow SD CI TRO | rharvey |
| | | SHA Prop. Video UOF Prst Supp Juv Bias Pris | |



Teaneck Police Department

900 Teaneck Rd, Teaneck, NJ 07666

Phone: 201-837-2600 Fax: 201-837-1880 Mun. Code: 0260

Incident Report



| Incident Details: | | | | | | | | | |
|-------------------|---------------|---------------|---------------|---------------|-----------------------------------|---------------|---------------|-----|-----------|
| Case Number | Time Reported | Date Reported | Time Occurred | Date Occurred | Occurrence Between Date / Time of | Time Occurred | Date Occurred | 911 | Completed |
| 19-049364 | 18:05 | 09/08/19 | 18:05 | 09/08/19 | | | | | X |

| Incident Type: | | | Incident Location: | | |
|---------------------------------|--|--|--------------------|-----------------|---------------------------------|
| Medical Emergency | | | Street # | Street Name | Intersection / Cross Street of: |
| | | | 18 | W Englewood Ave | W Englewood Ave / Teaneck |
| Business / Common Location Name | | | | | |

Contact Information: Victim Suspect Complainant Witness Driver Arrest Passenger Missing Involved Other

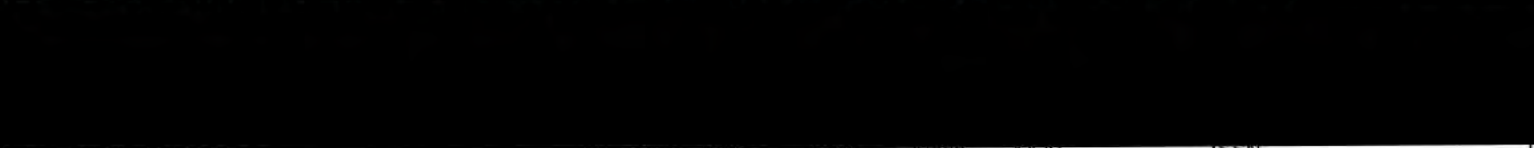

| | | | | | | | | |
|---------|-----------------|----|--------|-----|-----|------------|------------|-----|
| Code | Contact Name #2 | MI | Suffix | Age | Sex | Race | DOB | SSN |
| Address | | | | | | Home Phone | Cell Phone | |
| Code | Contact Name #3 | MI | Suffix | Age | Sex | Race | DOB | SSN |
| Address | | | | | | Home Phone | Cell Phone | |
| Code | Contact Name #4 | MI | Suffix | Age | Sex | Race | DOB | SSN |
| Address | | | | | | Home Phone | Cell Phone | |

| Property Information: | | | | | | | |
|------------------------------------|----------|---------|------|----------|------|-------|-------|
| Value of Stolen Property | Currency | Jewelry | Furs | Clothing | Auto | Misc. | Total |
| Value of Stolen Property Recovered | | | | | | | |

| Automobile Information: | | | | | | | | | |
|-------------------------|--------------|------|------|-----------|-------|-------|--------------|-------|-----|
| 1 | Vehicle Code | Year | Make | Body Type | Model | Color | Registration | State | VIN |
| 2 | | | | | | | | | |
| 3 | | | | | | | | | |
| 4 | | | | | | | | | |

Narrative:
Transported to HNMC.

| Officer of Record: | Date: | Other Reports Filed: | Reviewed By: |
|--------------------|----------|---|--------------|
| PO Arno Peters 280 | 09/08/19 | MVA Arrest DV DWI DWIQ Tow SD CI TRO SHA Prop. Video UOF Prst Supp Juv Bias Pris | pforrest |



Teaneck Police Department

900 Teaneck Rd, Teaneck, NJ 07666

Phone: 201-837-2600 Fax: 201-837-1880 Mun. Code: 0260

Incident Report



| Incident Details: | | | | | | | | | |
|-------------------|---------------|---------------|---------------|---------------|-----------------------------------|---------------|---------------|-----|-----------|
| Case Number | Time Reported | Date Reported | Time Occurred | Date Occurred | Occurrence Between Date / Time of | Time Occurred | Date Occurred | 911 | Completed |
| 20-020052 | 11:39 | 04/17/20 | 11:39 | 04/17/20 | | | | X | X |

| Incident Type: | Incident Location: |
|-------------------|---|
| Medical Emergency | Street # Street Name 18 W Englewood Ave Intersection / Cross Street of: W Englewood Ave / Teaneck Business / Common Location Name |

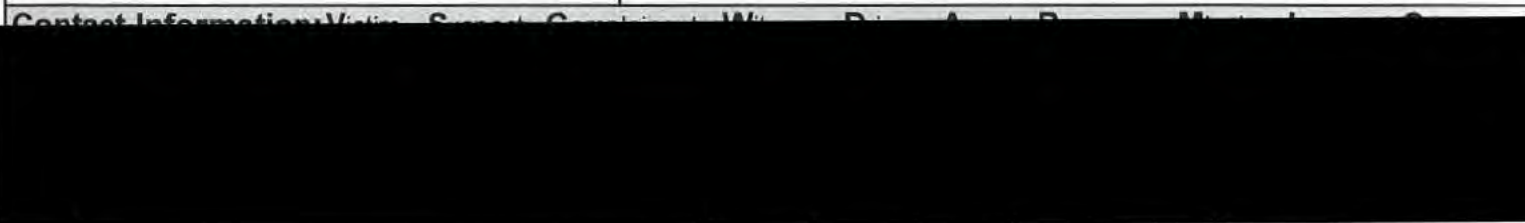

| | | | | | | | | | |
|---------|-----------------|----|--------|-----|-----|------------|-----|------------|--|
| Address | | | | | | Home Phone | | Cell Phone | |
| Code | Contact Name #3 | MI | Suffix | Age | Sex | Race | DOB | SSN | |
| Address | | | | | | Home Phone | | Cell Phone | |
| Code | Contact Name #4 | MI | Suffix | Age | Sex | Race | DOB | SSN | |
| Address | | | | | | Home Phone | | Cell Phone | |

| Property Information: | | | | | | | |
|------------------------------------|----------|---------|------|----------|------|-------|-------|
| Value of Stolen Property | Currency | Jewelry | Furs | Clothing | Auto | Misc. | Total |
| Value of Stolen Property Recovered | | | | | | | |

| Automobile Information: | | | | | | | | | |
|-------------------------|--------------|------|------|-----------|-------|-------|--------------|-------|-----|
| 1 | Vehicle Code | Year | Make | Body Type | Model | Color | Registration | State | VIN |
| 2 | | | | | | | | | |
| 3 | | | | | | | | | |
| 4 | | | | | | | | | |

Narrative:
One to Holy Name Medical Center.

| Officer of Record: | Date: | Other Reports Filed: | Reviewed By: |
|---------------------|----------|---|--------------|
| PO James Hoover 339 | 04/17/20 | MVA Arrest DV DWI DWIQ Tow SD CI TRO SHA Prop. Video UOF Prst Supp Juv Bias Pris | pforrest |



Teaneck Police Department

900 Teaneck Rd, Teaneck, NJ 07666

Phone: 201-837-2600 Fax: 201-837-1880 Mun. Code: 0260

Incident Report



Incident Details:

| | | | | | | | | | |
|-------------|---------------|---------------|---------------|---------------|-----------------------------------|---------------|---------------|-----|-----------|
| Case Number | Time Reported | Date Reported | Time Occurred | Date Occurred | Occurrence Between Date / Time of | Time Occurred | Date Occurred | 911 | Completed |
| 20-021798 | 16:53 | 05/01/20 | 16:53 | 05/01/20 | | | | X | X |

Incident Type:

Medical Emergency

Incident Location:

| | | |
|---------------------------------|-----------------|---------------------------------|
| Street # | Street Name | Intersection / Cross Street of: |
| 18 | W Englewood Ave | W Englewood Ave / Teaneck |
| Business / Common Location Name | | |

Contact Information: Victim Suspect Complainant Witness Driver Arrest Passenger Missing Involved Other

| | | | | | | | | | |
|---------|-----------------|----|--------|-----|------------|------|-----|------------|--|
| Address | | | | | Home Phone | | | Cell Phone | |
| Code | Contact Name #3 | MI | Suffix | Age | Sex | Race | DOB | SSN | |
| Address | | | | | Home Phone | | | Cell Phone | |
| Code | Contact Name #4 | MI | Suffix | Age | Sex | Race | DOB | SSN | |
| Address | | | | | Home Phone | | | Cell Phone | |

Property Information:

| | | | | | | | |
|------------------------------------|----------|---------|------|----------|------|-------|-------|
| Value of Stolen Property | Currency | Jewelry | Furs | Clothing | Auto | Misc. | Total |
| Value of Stolen Property Recovered | | | | | | | |

Automobile Information:

| 1 | Vehicle Code | Year | Make | Body Type | Model | Color | Registration | State | VIN |
|---|--------------|------|------|-----------|-------|-------|--------------|-------|-----|
| 2 | | | | | | | | | |
| 3 | | | | | | | | | |
| 4 | | | | | | | | | |

Narrative:

One to Holy Name Medical Center.

Officer of Record: Date: Other Reports Filed: Reviewed By:

| | | | |
|---------------------|----------|---|----------|
| PO James Hoover 339 | 05/01/20 | MVA Arrest DV DWI DWIQ Tow SD CI TRO SHA Prop. Video UOF Prst Supp Juv Bias Pris | pforrest |
|---------------------|----------|---|----------|



Teaneck Police Department

900 Teaneck Rd, Teaneck, NJ 07666

Phone: 201-837-2600 Fax: 201-837-1880 Mun. Code: 0260

Incident Report



Incident Details:

| | | | | | | | | | |
|-------------|---------------|---------------|---------------|---------------|-----------------------------------|---------------|---------------|-----|-----------|
| Case Number | Time Reported | Date Reported | Time Occurred | Date Occurred | Occurrence Between Date / Time of | Time Occurred | Date Occurred | 911 | Completed |
| 20-063546 | 20:49 | 12/25/20 | | | | | | X | |

Incident Type:

Medical Emergency

Incident Location:

| | | |
|---------------------------------|-----------------|---------------------------------|
| Street # | Street Name | Intersection / Cross Street of: |
| 18 | W Englewood Ave | W Englewood Ave / Teaneck |
| Business / Common Location Name | | |

Contact Information: Victim Suspect Complainant Witness Driver Arrest Passenger Missing Involved Other

| Code | Contact Name #1 | MI | Suffix | Age | Sex | Race | DOB | SSN |
|---------|-----------------|----|--------|-----|-----|------------|-----|------------|
| | | | | | | | | |
| Address | | | | | | Home Phone | | Cell Phone |
| | | | | | | | | |
| Address | | | | | | Home Phone | | Cell Phone |
| | | | | | | | | |
| Address | | | | | | Home Phone | | Cell Phone |
| | | | | | | | | |
| Address | | | | | | Home Phone | | Cell Phone |

Property Information:

| | | | | | | | |
|------------------------------------|----------|---------|------|----------|------|-------|-------|
| Value of Stolen Property | Currency | Jewelry | Furs | Clothing | Auto | Misc. | Total |
| Value of Stolen Property Recovered | | | | | | | |

Automobile Information:

| | Vehicle Code | Year | Make | Body Type | Model | Color | Registration | State | VIN |
|---|--------------|------|------|-----------|-------|-------|--------------|-------|-----|
| 1 | | | | | | | | | |
| 2 | | | | | | | | | |
| 3 | | | | | | | | | |
| 4 | | | | | | | | | |

Narrative:

Officer of Record: Date: Other Reports Filed: Reviewed By:

| | | | |
|-----------|----------|---|--|
| Ambulance | 12/25/20 | MVA Arrest DV DWI DWIQ Tow SD CI TRO SHA Prop. Video UOF Prst Supp Juv Bias Pris | |
|-----------|----------|---|--|



Teaneck Police Department

900 Teaneck Rd, Teaneck, NJ 07666

Phone: 201-837-2600 Fax: 201-837-1880 Mun. Code: 0260

Incident Report



Incident Details:

| | | | | | | | | | |
|-------------|---------------|---------------|---------------|---------------|-----------------------------------|---------------|---------------|-----|-----------|
| Case Number | Time Reported | Date Reported | Time Occurred | Date Occurred | Occurrence Between Date / Time of | Time Occurred | Date Occurred | 911 | Completed |
| 21-031220 | 23:57 | 06/13/21 | 23:57 | 06/13/21 | | | | X | X |

Incident Type:

Simple Assault 2C:12-1a
Police Information

Incident Location:

| | | |
|---------------------------------|-----------------|---------------------------------|
| Street # | Street Name | Intersection / Cross Street of: |
| 18 | W Englewood Ave | W Englewood Ave / Teaneck |
| Business / Common Location Name | | |

Contact Information: Victim Suspect Complainant Witness Driver Arrest Passenger Missing Involved Other

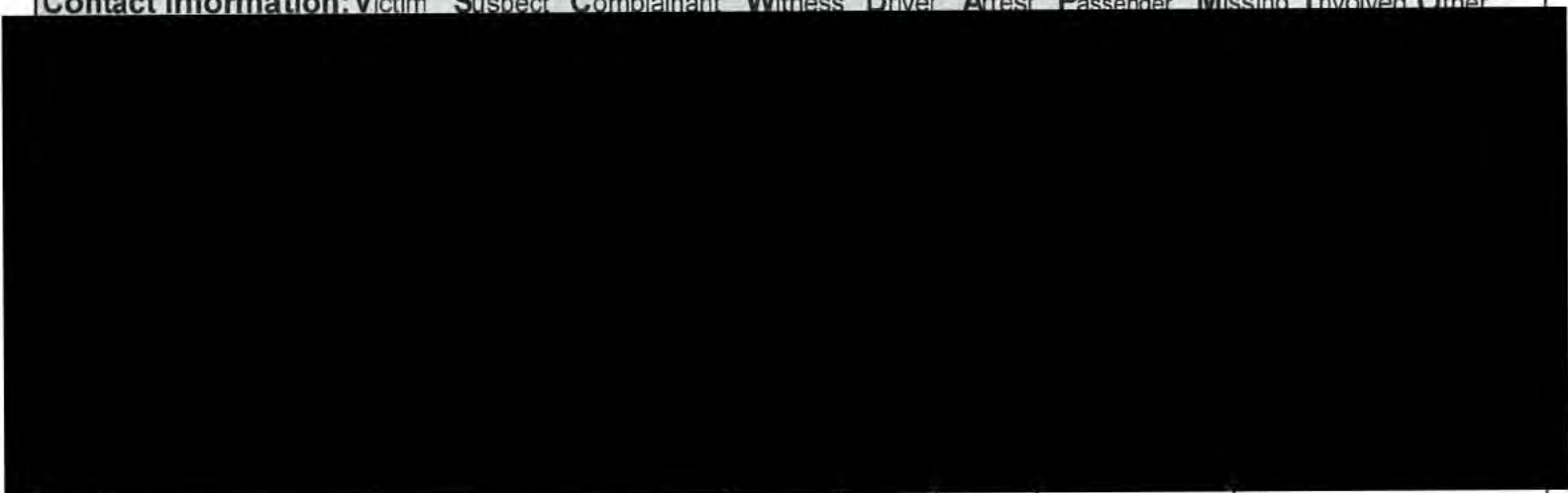

| | | |
|---------|------------|------------|
| Address | Home Phone | Cell Phone |
|---------|------------|------------|

Property Information:

| Value of Stolen Property | Currency | Jewelry | Furs | Clothing | Auto | Misc. | Total |
|------------------------------------|----------|---------|------|----------|------|-------|-------|
| Value of Stolen Property Recovered | | | | | | | |

Automobile Information:

| | Vehicle Code | Year | Make | Body Type | Model | Color | Registration | State | VIN |
|---|--------------|------|------|-----------|-------|-------|--------------|-------|-----|
| 1 | | | | | | | | | |
| 2 | | | | | | | | | |
| 3 | | | | | | | | | |
| 4 | | | | | | | | | |

Narrative:

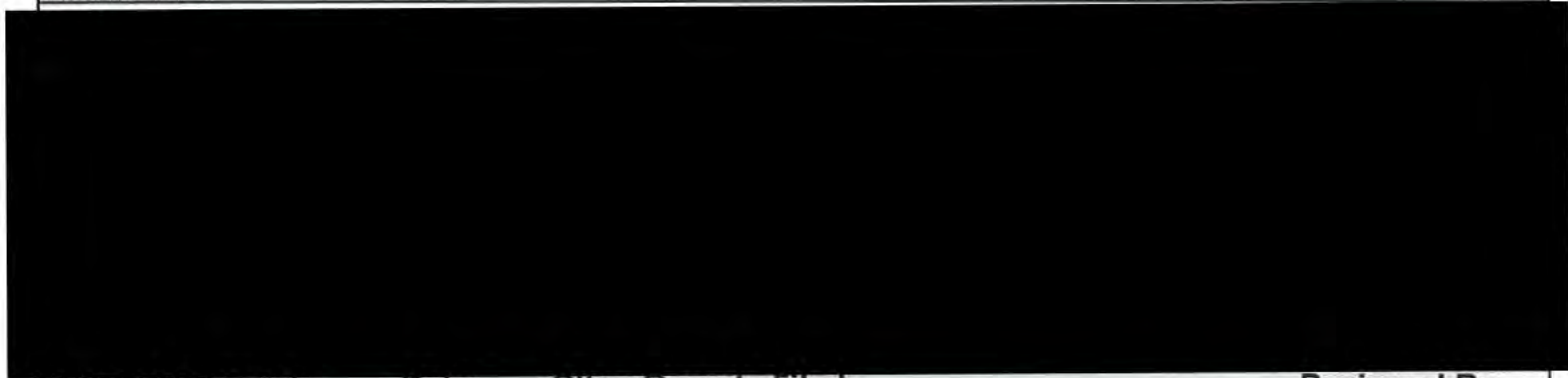

| | | | |
|-----------------------|----------|---|--------------|
| Officer of Record: | Date: | Other Reports Filed: | Reviewed By: |
| PO Douglas Strickland | 06/13/21 | MVA Arrest DV DWI DWIQ Tow SD CI TRO SHA Prop. Video UOF Prst Supp 1 Juv Bias Pris | papreda |



Teaneck Police Department

900 Teaneck Rd, Teaneck, NJ 07666

Phone: 201-837-2600 Fax: 201-837-1880 Mun. Code: 0260

Incident Report



Narrative Continued (Page 2)

Case Number

21-031220

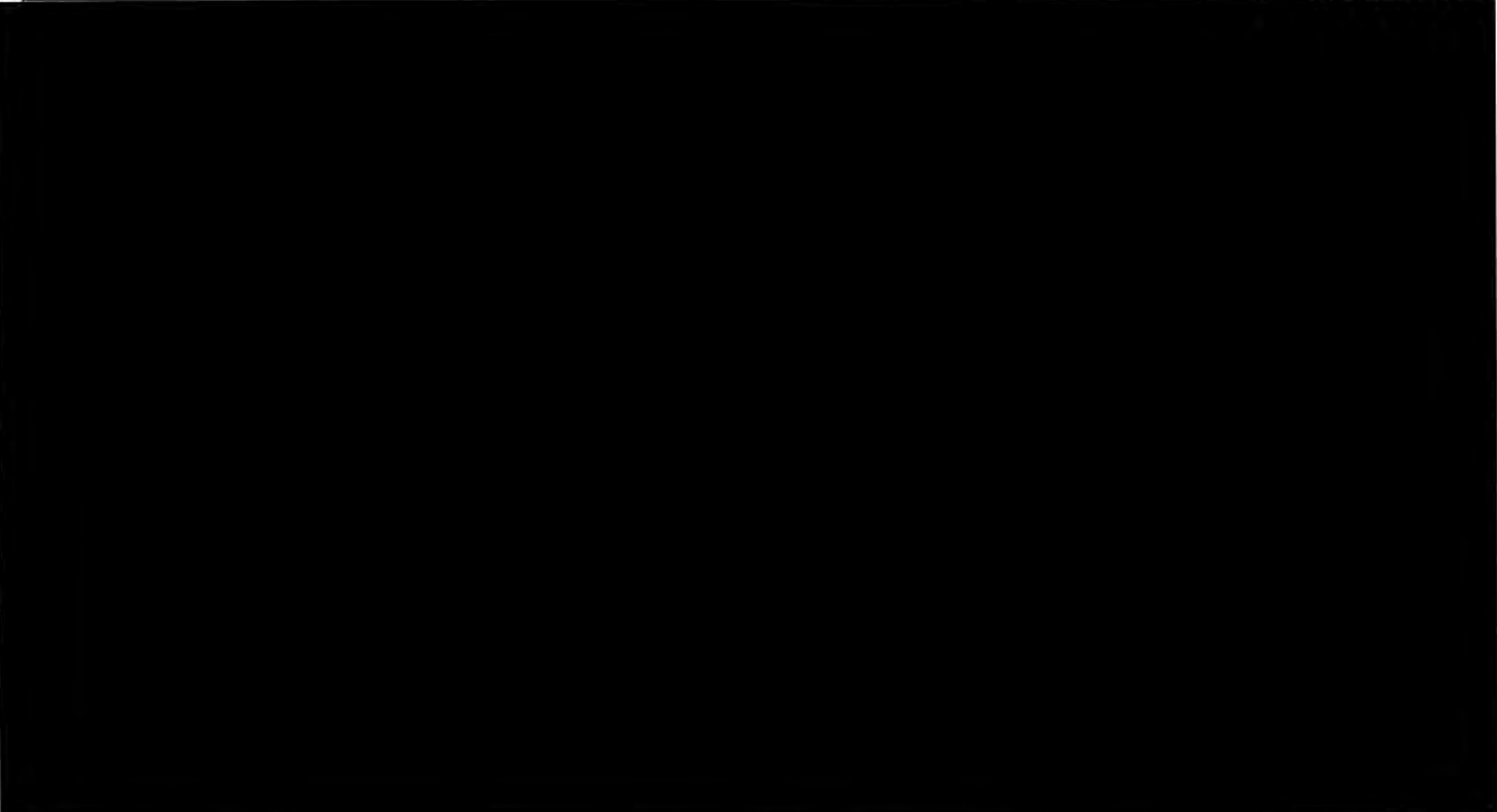

Submitted By: PO Douglas Strickland #358

Officer of Record:

Date:

PO Douglas Strickland 358

06/13/21



Teaneck Police Department

900 Teaneck Rd, Teaneck, NJ 07666

Phone: 201-837-2600 Fax: 201-837-1880 Mun. Code: 0260

Incident Report



| Incident Details: | | | | | | | | | |
|-------------------|---------------|---------------|---------------|---------------|-----------------------------------|---------------|---------------|-----|-----------|
| Case Number | Time Reported | Date Reported | Time Occurred | Date Occurred | Occurrence Between Date / Time of | Time Occurred | Date Occurred | 911 | Completed |
| 21-035826 | 15:33 | 07/06/21 | 15:33 | 07/06/21 | | | | X | X |

| Incident Type: | | | Incident Location: | | |
|-------------------|--|--|---------------------------------|-----------------|---------------------------------|
| Medical Emergency | | | Street # | Street Name | Intersection / Cross Street of: |
| | | | 18 | W Englewood Ave | W Englewood Ave / Teaneck |
| | | | Business / Common Location Name | | |



| | | | | | | | | |
|---------|-----------------|----|------------|-----|-----|------------|-----|-----|
| Address | | | Home Phone | | | Cell Phone | | |
| Code | Contact Name #3 | MI | Suffix | Age | Sex | Race | DOB | SSN |
| Address | | | Home Phone | | | Cell Phone | | |
| Code | Contact Name #4 | MI | Suffix | Age | Sex | Race | DOB | SSN |
| Address | | | Home Phone | | | Cell Phone | | |

| Property Information: | | | | | | | |
|------------------------------------|----------|---------|------|----------|------|-------|-------|
| Value of Stolen Property | Currency | Jewelry | Furs | Clothing | Auto | Misc. | Total |
| Value of Stolen Property Recovered | | | | | | | |

| Automobile Information: | | | | | | | | | |
|-------------------------|--------------|------|------|-----------|-------|-------|--------------|-------|-----|
| 1 | Vehicle Code | Year | Make | Body Type | Model | Color | Registration | State | VIN |
| 2 | | | | | | | | | |
| 3 | | | | | | | | | |
| 4 | | | | | | | | | |

Narrative:
 1 transported to HNMC.

| | | | |
|---------------------------|--------------|---|---------------------|
| Officer of Record: | Date: | Other Reports Filed: | Reviewed By: |
| PO Daiana Jackson 369 | 07/06/21 | MVA Arrest DV DWI DWIQ Tow SD CI TRO SHA Prop. Video UOF Prst Supp Juv Bias Pris | ttully |



Teaneck Police Department

900 Teaneck Rd, Teaneck, NJ 07666

Phone: 201-837-2600 Fax: 201-837-1880 Mun. Code: 0260

Incident Report



Incident Details:

| | | | | | | | | | |
|-------------|---------------|---------------|---------------|---------------|-----------------------------------|---------------|---------------|-----|-----------|
| Case Number | Time Reported | Date Reported | Time Occurred | Date Occurred | Occurrence Between Date / Time of | Time Occurred | Date Occurred | 911 | Completed |
| 21-048455 | 12:30 | 09/04/21 | 12:30 | 09/04/21 | | | | X | X |

Incident Type:

Medical Emergency

Incident Location:

| | | |
|---------------------------------|-----------------|---------------------------------|
| Street # | Street Name | Intersection / Cross Street of: |
| 18 | W Englewood Ave | W Englewood Ave / Teaneck |
| Business / Common Location Name | | |

| | | | | | | | | | |
|---------|-----------------|----|--------|-----|-----|------------|-----|------------|--|
| Address | | | | | | Home Phone | | Cell Phone | |
| Code | Contact Name #3 | MI | Suffix | Age | Sex | Race | DOB | SSN | |
| Address | | | | | | Home Phone | | Cell Phone | |
| Code | Contact Name #4 | MI | Suffix | Age | Sex | Race | DOB | SSN | |
| Address | | | | | | Home Phone | | Cell Phone | |

Property Information:

| | | | | | | | |
|------------------------------------|----------|---------|------|----------|------|-------|-------|
| Value of Stolen Property | Currency | Jewelry | Furs | Clothing | Auto | Misc. | Total |
| Value of Stolen Property Recovered | | | | | | | |

Automobile Information:

| 1 | Vehicle Code | Year | Make | Body Type | Model | Color | Registration | State | VIN |
|---|--------------|------|------|-----------|-------|-------|--------------|-------|-----|
| 2 | | | | | | | | | |
| 3 | | | | | | | | | |
| 4 | | | | | | | | | |

Narrative:

One male transported to Holy Name Medical Center.

P.O Alexis Frischer #364

Officer of Record: Date: Other Reports Filed: Reviewed By:

| | | | |
|------------------------|----------|--|----------|
| PO Alexis Frischer 364 | 09/04/21 | MVA Arrest DV DWI DWI/Q Tow SD CI TRO SHA Prop. Video UOF Prst Supp Juv Bias Pris | pforrest |
|------------------------|----------|--|----------|



Teaneck Police Department

900 Teaneck Rd, Teaneck, NJ 07666

Phone: 201-837-2600 Fax: 201-837-1880 Mun. Code: 0260

Incident Report



| Incident Details: | | | | | | | | | |
|-------------------|---------------|---------------|---------------|---------------|-----------------------------------|---------------|---------------|-----|-----------|
| Case Number | Time Reported | Date Reported | Time Occurred | Date Occurred | Occurrence Between Date / Time of | Time Occurred | Date Occurred | 911 | Completed |
| 21-060045 | 10:17 | 10/29/21 | 10:17 | 10/29/21 | | | | X | X |

| Incident Type: | | Incident Location: | |
|-------------------|--|--|-----------------|
| Medical Emergency | | Street # | Street Name |
| | | 18 | W Englewood Ave |
| | | Intersection / Cross Street of: W Englewood Ave / Teaneck | |
| | | Business / Common Location Name | |

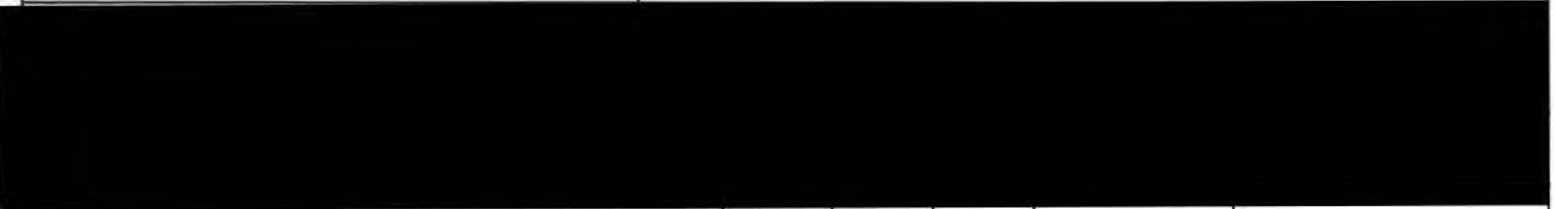

| | | | | | | | | | |
|---------|-----------------|----|--------|-----|-----|------------|-----|------------|--|
| Address | | | | | | Home Phone | | Cell Phone | |
| Code | Contact Name #3 | MI | Suffix | Age | Sex | Race | DOB | SSN | |
| Address | | | | | | Home Phone | | Cell Phone | |
| Code | Contact Name #4 | MI | Suffix | Age | Sex | Race | DOB | SSN | |
| Address | | | | | | Home Phone | | Cell Phone | |

| Property Information: | | | | | | | |
|------------------------------------|----------|---------|------|----------|------|-------|-------|
| Value of Stolen Property | Currency | Jewelry | Furs | Clothing | Auto | Misc. | Total |
| Value of Stolen Property Recovered | | | | | | | |

| Automobile Information: | | | | | | | | | |
|-------------------------|--------------|------|------|-----------|-------|-------|--------------|-------|-----|
| 1 | Vehicle Code | Year | Make | Body Type | Model | Color | Registration | State | VIN |
| 2 | | | | | | | | | |
| 3 | | | | | | | | | |
| 4 | | | | | | | | | |

Narrative:
 TVAC transported one male party to Englewood Hospital.

 Submitted by: PO. Ruscigno #356

| Officer of Record: | Date: | Other Reports Filed: | | | | | | | | | | Reviewed By: |
|----------------------|----------|----------------------|--------|-------|-----|------|------|-----|------|------|--|--------------|
| PO Nicholas Ruscigno | 10/29/21 | MVA | Arrest | DV | DWI | DWIQ | Tow | SD | CI | TRO | | wcrownquist |
| | | SHA | Prop. | Video | UOF | Prst | Supp | Juv | Bias | Pris | | |



Teaneck Police Department

900 Teaneck Rd, Teaneck, NJ 07666

Phone: 201-837-2600 Fax: 201-837-1880 Mun. Code: 0260

Incident Report



| Incident Details: | | | | | | | | | |
|-------------------|---------------|---------------|---------------|---------------|-----------------------------------|---------------|---------------|-----|-----------|
| Case Number | Time Reported | Date Reported | Time Occurred | Date Occurred | Occurrence Between Date / Time of | Time Occurred | Date Occurred | 911 | Completed |
| 18-021593 | 17:03 | 05/24/18 | 17:03 | 05/24/18 | | | | X | X |

| Incident Type: | Incident Location: | | | | | | | | | |
|---------------------------------|---|---------------------------------|-------------|---------------------------------|------|--------------|--|---------------------------------|--|--|
| Shoplifting 2C:20-11 | <table border="1"> <tr> <td>Street #</td> <td>Street Name</td> <td>Intersection / Cross Street of:</td> </tr> <tr> <td>1360</td> <td>Teaneck Road</td> <td></td> </tr> <tr> <td colspan="3">Business / Common Location Name</td> </tr> </table> | Street # | Street Name | Intersection / Cross Street of: | 1360 | Teaneck Road | | Business / Common Location Name | | |
| Street # | Street Name | Intersection / Cross Street of: | | | | | | | | |
| 1360 | Teaneck Road | | | | | | | | | |
| Business / Common Location Name | | | | | | | | | | |

Contact Information: Victim Suspect Complainant Witness Driver Arrest Passenger Missing Involved Other

| Property Information: | | | | | | | |
|------------------------------------|----------|---------|------|----------|------|--------|--------|
| Value of Stolen Property | Currency | Jewelry | Furs | Clothing | Auto | Misc. | Total |
| | | | | | | \$9.00 | \$9.00 |
| Value of Stolen Property Recovered | | | | | | | |

| Automobile Information: | | | | | | | | | |
|-------------------------|--------------|------|------|-----------|-------|-------|--------------|-------|-----|
| | Vehicle Code | Year | Make | Body Type | Model | Color | Registration | State | VIN |
| 1 | | | | | | | | | |
| 2 | | | | | | | | | |
| 3 | | | | | | | | | |
| 4 | | | | | | | | | |

Narrative:
See Page #2

Report # 18-664848 exists involving a robbery at 1360 Teaneck Road on 12/31/2018. 5 actors were arrested, however, at least one of the actors was granted an expungement which has not yet been processed.

| Officer of Record: | Date: | Other | Reviewed By: |
|-----------------------|----------|------------|-----------------------|
| PO Steven Batista 325 | 05/24/18 | MVA SHA | TRO Pris ttully |



Teaneck Police Department

900 Teaneck Rd, Teaneck, NJ 07666

Phone: 201-837-2600 Fax: 201-837-1880 Mun. Code: 0260

Incident Report



Narrative Continued (Page 2)

Case Number

18-021593

Officer of Record:

Date:

PO Steven Batista 325

05/24/18



Teaneck Police Department

900 Teaneck Rd, Teaneck, NJ 07666

Phone: 201-837-2600 Fax: 201-837-1880 Mun. Code: 0260

Incident Report



Narrative Continued (Page 3)

Case Number

18-021593

Officer Steven Batista #325

Officer of Record:

Date:

PO Steven Batista 325

05/24/18



Teaneck Police Department

900 Teaneck Rd, Teaneck, NJ 07666

Phone: 201-837-2600 Fax: 201-837-1880 Mun. Code: 0260



Incident Report - Additional Contacts

| Incident Details: | | | | | | | | | |
|----------------------|---------------|---------------|---------------|---------------------------------|-----------------------------------|---------------|---------------------------------|-----|-----------|
| Case Number | Time Reported | Date Reported | Time Occurred | Date Occurred | Occurrence Between Date / Time of | Time Occurred | Date Occurred | 911 | Completed |
| 18-021593 | 17:03 | 05/24/18 | 17:03 | 05/24/18 | | | | X | X |
| Incident Type: | | | | Incident Location: | | | | | |
| Shoplifting 2C:20-11 | | | | Street # | Street Name | | Intersection / Cross Street of: | | |
| | | | | 1360 | Teaneck Road | | | | |
| | | | | Business / Common Location Name | | | | | |

| 187 Robinson Street, Teaneck, NJ 07666 | | | | 201-862-1193 | | | | | | | |
|--|----------|----------------------|--------|--------------|-----|------|--------|-----|------|----------|-------|
| Officer of | Date | Other Reports Filed: | | | | | | | | Reviewed | |
| PO Steven Batista 325 | 05/24/18 | MVA < T | Arrest | DV | DWI | DWIQ | Tow | SD | CI | TRO | TTULL |
| | | SHA | Prop | Evdn | UOF | Prst | Supp X | Juv | Bias | Pris | |



Teaneck Police Department

900 Teaneck Rd, Teaneck, NJ 07666

Phone: 201-837-2600 Fax: 201-837-1880 Mun. Code: 0260

Supplemental Investigation Report



Incident Details:

| | | | | | | | | | |
|-------------|---------------|---------------|---------------|---------------|-----------------------------------|---------------|---------------|-----|-----------|
| Case Number | Time Reported | Date Reported | Time Occurred | Date Occurred | Occurrence Between Date / Time of | Time Occurred | Date Occurred | 911 | Completed |
| 18-021593A | | 05/24/18 | 17:03 | 05/24/18 | | | | | X |

Incident Type:

Investigation Follow-Up

Incident Location:

| | | |
|---------------------------------|--------------|---------------------------------|
| Street # | Street Name | Intersection / Cross Street of: |
| 1360 | Teaneck Road | |
| Business / Common Location Name | | |

| | | | | | | | |
|------------------------------------|----------|---------|------|----------|------|-------|-------|
| Value of Stolen Property | Currency | Jewelry | Furs | Clothing | Auto | Misc. | Total |
| Value of Stolen Property Recovered | | | | | | | |

Automobile Information:

| | Vehicle Code | Year | Make | Body Type | Model | Color | Registration | State | VIN |
|---|--------------|------|------|-----------|-------|-------|--------------|-------|-----|
| 1 | | | | | | | | | |
| 2 | | | | | | | | | |
| 3 | | | | | | | | | |
| 4 | | | | | | | | | |

Narrative:

Supplemental Report For Additional Names

| | | | |
|---------------------------|--------------|---|---------------------|
| Officer of Record: | Date: | Other Reports Filed: | Reviewed By: |
| PO Steven Batista 325 | 05/24/18 | MVA Arrest DV DWI DWIQ Tow SD CI TRO SHA Prop. Video UOF Prst Supp 2 Juv Bias Pris | ttully |



Teaneck Police Department

900 Teaneck Rd, Teaneck, NJ 07666

Phone: 201-837-2600 Fax: 201-837-1880 Mun. Code: 0260

Incident Report



Incident Details:

| | | | | | | | | | |
|-------------|---------------|---------------|---------------|---------------|-----------------------------------|---------------|---------------|-----|-----------|
| Case Number | Time Reported | Date Reported | Time Occurred | Date Occurred | Occurrence Between Date / Time of | Time Occurred | Date Occurred | 911 | Completed |
| 18-063609 | 11:54 | 12/24/18 | 10:10 | 12/24/18 | | 10:30 | 12/24/18 | | X |

Incident Type:

Lost Property

Incident Location:

| | | |
|---------------------------------|-------------|---------------------------------|
| Street # | Street Name | Intersection / Cross Street of: |
| 1360 | Teaneck Rd | |
| Business / Common Location Name | | |

| | | | | | | | |
|------------------------------------|----------|---------|------|----------|------|-------|-------|
| Value of Stolen Property | Currency | Jewelry | Furs | Clothing | Auto | Misc. | Total |
| Value of Stolen Property Recovered | | | | | | | |

Automobile Information:

| 1 | Vehicle Code | Year | Make | Body Type | Model | Color | Registration | State | VIN |
|---|--------------|------|------|-----------|-------|-------|--------------|-------|-----|
| 2 | | | | | | | | | |
| 3 | | | | | | | | | |
| 4 | | | | | | | | | |

Narrative:

On Monday, December 24, 2018, at 11:54 AM [REDACTED] responded to Teaneck Police Headquarters to report she had lost her Coach wallet.

[REDACTED] report that she lost her Coach wallet valued at \$50.00 in Ebony Beauty Supply located at 1360 Teaneck Road today between the times of 10:10 AM and 10:30 AM.

She reported that the following item's were in her wallet:

1. New Jersey Driver's License #W43920157756772
2. Bank of America Debit card

| | | | |
|---------------------------|--------------|---|---------------------|
| Officer of Record: | Date: | Other Reports Filed: | Reviewed By: |
| PO Constantinos Skoufas | 12/24/18 | MVA Arrest DV DWI DWIQ Tow SD CI TRO SHA Prop. Video UOF Prst Supp Juv Bias Pris | pforrest |



Teaneck Police Department

900 Teaneck Rd, Teaneck, NJ 07666

Phone: 201-837-2600 Fax: 201-837-1880 Mun. Code: 0260

Incident Report



Narrative Continued (Page 2)

Case Number

18-063609

3. Aetna Health Card
4. New Jersey Snap EBT Card
5. New Jersey Medicaid Card
6. Teaneck Library Card
7. \$10.00 cash

[REDACTED] reported that she cancelled her debit card and I also handed her an identity theft packet for precautionary measures for her to read over.

[REDACTED] completed a Civillian Report Form which I attached to the report.

I also notified Det. G. Breit via E-mail from the Bergen County Prosecutors Office as per protocol whenever a drivers license is lost or stolen.

Police Officer: Constantinos Skoufas #327

Officer of Record:

Date:

PO Constantinos Skoufas 327

12/24/18



Teaneck Police Department

900 Teaneck Rd, Teaneck, NJ 07666

Phone: 201-837-2600 Fax: 201-837-1880 Mun. Code: 0260

Incident Report



| Incident Details: | | | | | | | | | |
|-------------------|---------------|---------------|---------------|---------------|-----------------------------------|---------------|---------------|-----|-----------|
| Case Number | Time Reported | Date Reported | Time Occurred | Date Occurred | Occurrence Between Date / Time of | Time Occurred | Date Occurred | 911 | Completed |
| 20-047823 | 13:13 | 09/23/20 | 18:30 | 09/22/20 | | | | | X |

| Incident Type: | Incident Location: | |
|---------------------------------|---|--------------|
| Lost Property | Street # | Street Name |
| | 1360 | Teaneck Road |
| | Intersection / Cross Street of: Teaneck Road / W | |
| Business / Common Location Name | | |

Contact Information: Victim Suspect Complainant Witness Driver Arrest Passenger Missing Involved Other

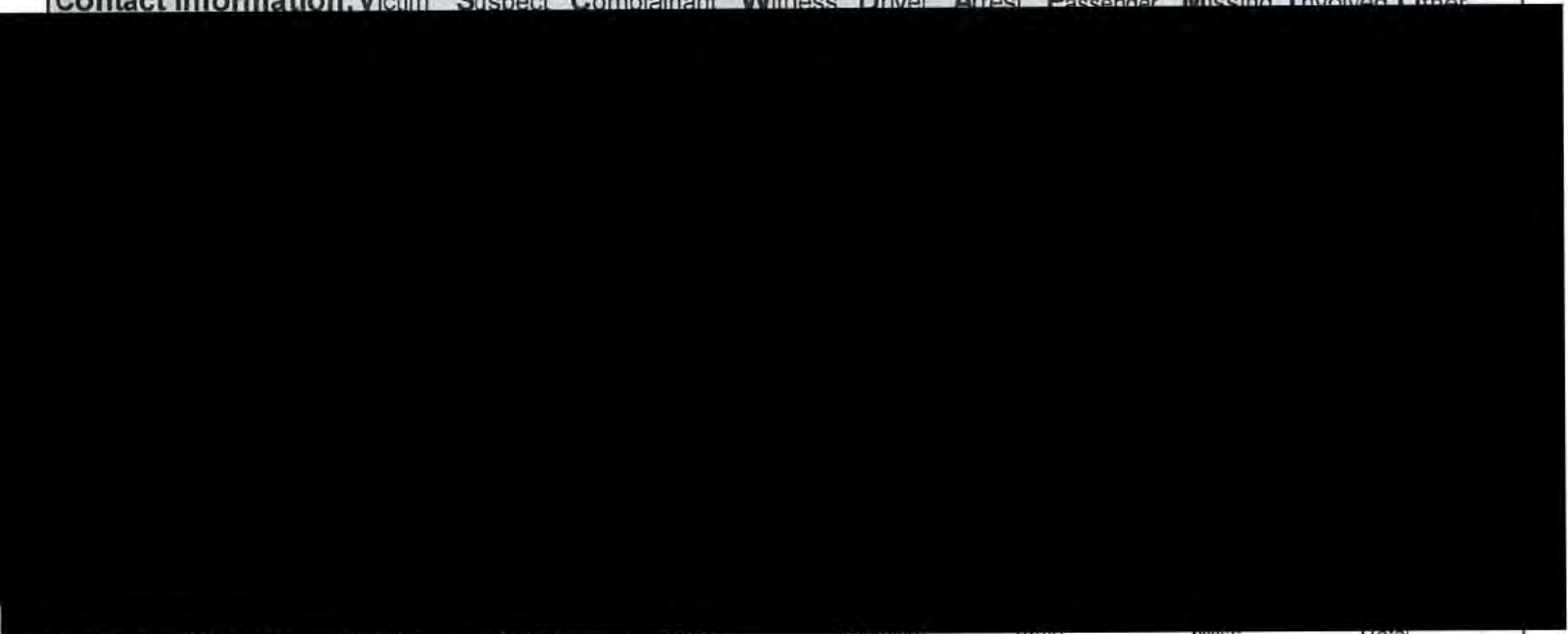

| | | | | | | | |
|------------------------------------|---------|---------|------|----------|------|-------|-------|
| Value of Stolen Property | Jewelry | Jewelry | Furs | Clothing | Auto | Misc. | Total |
| Value of Stolen Property Recovered | | | | | | | |

| Automobile Information: | | | | | | | | | |
|-------------------------|--------------|------|------|-----------|-------|-------|--------------|-------|-----|
| | Vehicle Code | Year | Make | Body Type | Model | Color | Registration | State | VIN |
| 1 | | | | | | | | | |
| 2 | | | | | | | | | |
| 3 | | | | | | | | | |
| 4 | | | | | | | | | |

Narrative:
 On Wednesday, September 23, 2020 at approximately 1:13 p.m., [REDACTED] submitted a lost wallet report via e-mail.
 She stated the following: "Went into Ebony Beauty Supply and believed to have put my wallet back in my bag upon making a purchase, I must've dropped it at some point from the store to the car or inside the store. The store reported no found wallet. Contained my license, bank card, credit cards."
 She reported the wallet lost on Tuesday, September 22, 2020 at approximately 6:30 p.m.

| Officer of Record: | Date: | Other Reports Filed: | | | | | | | | | | Reviewed By: |
|------------------------|----------|----------------------|--------|-------|-----|------|------|-----|------|------|--|--------------|
| PO Victoria Suarez 320 | 09/23/20 | MVA | Arrest | DV | DWI | DWIQ | Tow | SD | CI | TRO | | pforrest |
| | | SHA | Prop. | Video | UOF | Prst | Supp | Juv | Bias | Pris | | |



Teaneck Police Department

900 Teaneck Rd, Teaneck, NJ 07666

Phone: 201-837-2600 Fax: 201-837-1880 Mun. Code: 0260

Incident Report



Narrative Continued (Page 2)

Case Number

20-047823

██████████ stated that she contacted her financial institutions and froze her accounts. She said that she submitted an online request for a duplicate of her New Jersey driver license.

Officer of Record:

Date:

PO Victoria Suarez 320

09/23/20



Teaneck Police Department

900 Teaneck Rd, Teaneck, NJ 07666

Phone: 201-837-2600 Fax: 201-837-1880 Mun. Code: 0260

Incident Report



Incident Details:

| Case Number | Time Reported | Date Reported | Time Occurred | Date Occurred | Occurrence Between Date / Time of | Time Occurred | Date Occurred | 911 | Completed |
|-------------|---------------|---------------|---------------|---------------|-----------------------------------|---------------|---------------|-----|-----------|
| 21-044218 | 11:02 | 08/15/21 | 17:00 | 08/14/21 | | 17:30 | 08/14/21 | | X |

Incident Type:

Shoplifting 2C:20-11

Incident Location:

Street # Street Name Intersection / Cross Street of:
 1360 Teaneck Road Teaneck Road / W
 Business / Common Location Name



| Value of Stolen Property | Currency | Jewelry | Furs | Clothing | Auto | Misc. | Total |
|------------------------------------|----------|---------|------|----------|------|---------|---------|
| | | | | | | \$33.00 | \$33.00 |
| Value of Stolen Property Recovered | | | | | | | |

Automobile Information:

| | Vehicle Code | Year | Make | Body Type | Model | Color | Registration | State | VIN |
|---|--------------|------|------|-----------|-------|-------|--------------|-------|-----|
| 1 | | | | | | | | | |
| 2 | | | | | | | | | |
| 3 | | | | | | | | | |
| 4 | | | | | | | | | |

Narrative:

On Sunday, August 15, 2021 at approximately 11:02 AM, I responded to 1360 Teaneck Road, Ebony Beauty Supplies, on a report of a shoplifting in the past. I responded in a routine manner.



| Officer of Record: | Date: | Other Reports Filed: | Reviewed By: |
|-------------------------|----------|---|--------------|
| PO Melissa Terpstra 365 | 08/15/21 | MVA Arrest DV DWI DWIQ Tow SD CI TRO SHA Prop. Video UOF Prst Supp 1 Juv Bias Pris | kmarrero |



Teaneck Police Department

900 Teaneck Rd, Teaneck, NJ 07666

Phone: 201-837-2600 Fax: 201-837-1880 Mun. Code: 0260

Incident Report



Narrative Continued (Page 2)

Case Number

21-044218

This interaction can be found of the Mobile Video Recorder (MVR) of vehicle #16.

Officer of Record:

Date:

PO Melissa Terpstra 365

08/15/21



Teaneck Police Department

900 Teaneck Rd, Teaneck, NJ 07666

Phone: 201-837-2600 Fax: 201-837-1880 Mun. Code: 0260

Incident Report



Incident Details:

| | | | | | | | | | |
|-------------|---------------|---------------|---------------|---------------|-----------------------------------|---------------|---------------|-----|-----------|
| Case Number | Time Reported | Date Reported | Time Occurred | Date Occurred | Occurrence Between Date / Time of | Time Occurred | Date Occurred | 911 | Completed |
| 22-026720 | 15:57 | 05/12/22 | 15:57 | 05/12/22 | | | | | X |

Incident Type:

Shoplifting 2C:20-11

Incident Location:

Street # Street Name Intersection / Cross Street of:
 1360 Teaneck Rd Teaneck Road / W

Business / Common Location Name
 Ebony Beauty Supplies

Property Information:

| | | | | | | | |
|------------------------------------|----------|---------|------|----------|------|--------|--------|
| Value of Stolen Property | Currency | Jewelry | Furs | Clothing | Auto | Misc. | Total |
| | | | | | | \$4.99 | \$4.99 |
| Value of Stolen Property Recovered | | | | | | | |

Automobile Information:

| | Vehicle Code | Year | Make | Body Type | Model | Color | Registration | State | VIN |
|---|--------------|------|------|-----------|-------|-------|--------------|-------|-----|
| 1 | | | | | | | | | |
| 2 | | | | | | | | | |
| 3 | | | | | | | | | |
| 4 | | | | | | | | | |

Narrative:

On Thursday, May 12, 2021 at 3:57 PM, I responded to 1360 Teneck Road, Ebony Beauty Supplies, on a report of a shoplifting in the past.

Officer of Record: Date: Other Reports Filed: Reviewed By:

| | | | |
|-----------------------|----------|---|-----------|
| PO Steven Batista 325 | 05/12/22 | MVA Arrest DV DWI DWIQ Tow SD CI TRO SHA Prop. Video UOF Prst Supp Juv Bias Pris | cantinori |
|-----------------------|----------|---|-----------|



Teaneck Police Department

900 Teaneck Rd, Teaneck, NJ 07666

Phone: 201-837-2600 Fax: 201-837-1880 Mun. Code: 0260

Incident Report



Narrative Continued (Page 2)

Case Number

22-026720

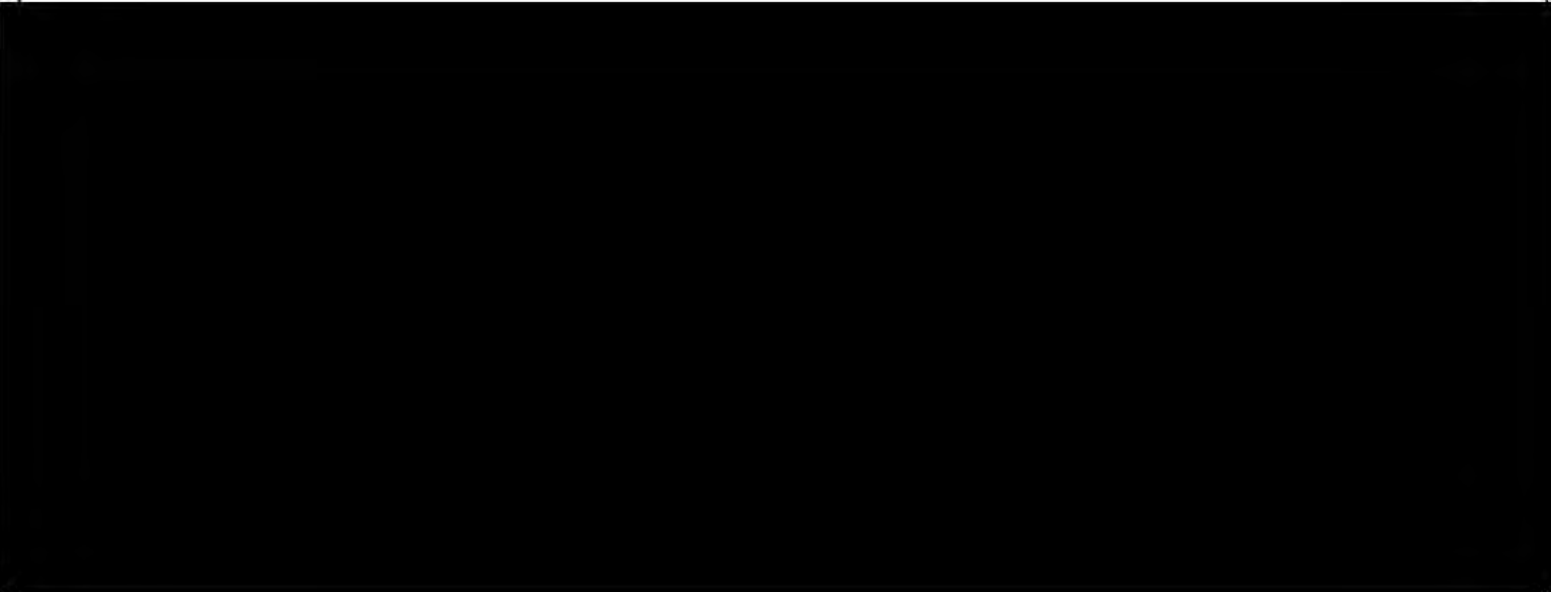

Officer of Record:

Date:

PO Steven Batista 325

05/12/22



Teaneck Police Department

900 Teaneck Rd, Teaneck, NJ 07666

Phone: 201-837-2600 Fax: 201-837-1880 Mun. Code: 0260

Incident Report



| Incident Details: | | | | | | | | | |
|-------------------|---------------|---------------|---------------|---------------|-----------------------------------|---------------|---------------|-----|-----------|
| Case Number | Time Reported | Date Reported | Time Occurred | Date Occurred | Occurrence Between Date / Time of | Time Occurred | Date Occurred | 911 | Completed |
| 22-015397 | 19:30 | 03/18/22 | 19:30 | 03/18/22 | | | | | X |

| Incident Type: | Incident Location: |
|--------------------|---|
| Police Information | Street # Street Name Intersection / Cross Street of: 1362 Teaneck Road Teaneck Road / W Business / Common Location Name |



| | | | | | | | | |
|---------|-----------------|----|--------|-----|-----|------------|------------|-----|
| Code | Contact Name #2 | MI | Suffix | Age | Sex | Race | DOB | SSN |
| I | | | | | | | | |
| Address | | | | | | Home Phone | Cell Phone | |
| Code | Contact Name #3 | MI | Suffix | Age | Sex | Race | DOB | SSN |
| | | | | | | | | |
| Address | | | | | | Home Phone | Cell Phone | |
| Code | Contact Name #4 | MI | Suffix | Age | Sex | Race | DOB | SSN |
| | | | | | | | | |
| Address | | | | | | Home Phone | Cell Phone | |

| Property Information: | | | | | | | |
|------------------------------------|----------|---------|------|----------|------|-------|-------|
| Value of Stolen Property | Currency | Jewelry | Furs | Clothing | Auto | Misc. | Total |
| Value of Stolen Property Recovered | | | | | | | |

| Automobile Information: | | | | | | | | | |
|-------------------------|--------------|------|------|-----------|-------|-------|--------------|-------|-----|
| 1 | Vehicle Code | Year | Make | Body Type | Model | Color | Registration | State | VIN |
| 2 | | | | | | | | | |
| 3 | | | | | | | | | |
| 4 | | | | | | | | | |

Narrative:
 On March 18, 2022, at approximately 7:30 PM, P.O. W.Pena #372 and I responded to 1352 Teaneck Road, H&S Discount Liquors, on a report of an activated burglar alarm.
 Upon arrival, I spoke with the owner [REDACTED] who advised that he pressed his panic alarm due to a verbal argument with a known customer that goes by the name " Flex". He stated that the customer is a known alcoholic who has been constantly coming into the business starting issues. He stated that tonight the party was intoxicated and came into the store asking " Where is Sunny" [REDACTED] He stated that " Flex" then acted as he was going to pick up a bottle and come behind the counter.

| Officer of Record: | Date: | Other Reports Filed: | Reviewed By: |
|-----------------------|----------|---|--------------|
| PO Daiana Jackson 369 | 03/18/22 | MVA Arrest DV DWI DWIQ Tow SD CI TRO SHA Prop. Video UOF Prst Supp Juv Bias Pris | rmorales |



Teaneck Police Department

900 Teaneck Rd, Teaneck, NJ 07666

Phone: 201-837-2600 Fax: 201-837-1880 Mun. Code: 0260

Incident Report



Narrative Continued (Page 2)

Case Number

22-015397

He stated that he also told him to come outside so that he can "black his eye".

At this time, [REDACTED] stated that he did not want to file complaints and that he did not fear for his safety. [REDACTED] advised that he did not want "Flex" coming back into the store. He described him as a 5'8 African American male who drives a red pick up truck.

[REDACTED] stated that the actor left prior to our arrival. A check of surrounding area was conducted with negative results. [REDACTED] was unable to provide the security camera footage at this time. [REDACTED] was advised that if the party comes back to give Police headquarters a call.

Submitted By: PO Daiana Jackson #369

Officer of Record:

Date:

PO Daiana Jackson 369

03/18/22



Teaneck Police Department

900 Teaneck Rd, Teaneck, NJ 07666

Phone: 201-837-2600 Fax: 201-837-1880 Mun. Code: 0260

CAD Report



| Incident Details: | | | Incident Location: | | Disposition |
|-------------------|-------|----------|---------------------------------|--|------------------|
| Case Number | Time | Date | Address | | Disposition |
| PD-17-027957 | 07:00 | 07/29/17 | 1364 TEANECK ROAD, TEANECK TWP, | | Report Completed |

| Incident Type: | | | | Dispatched By | | | Created By | |
|--------------------|---------|-----------------|---------|---------------|---------|--------------|------------|--|
| Malicious Mischief | | | | Tchal | | | Dcost | |
| Unit | Officer | Unit | Officer | Unit | Officer | Unit | Officer | |
| 299 | Pwest | 325 | Sbati | 306 | Rmora | 344 | Mspan | |
| Time Received | | Time Dispatched | | Time Arrived | | Time Cleared | | |
| 0700 | | 0702 | | 0703 | | 0714 | | |

| Contact Information: | | | | | | | | |
|----------------------|--------------|---------|--|--|-----|-----|------|-------|
| Role | Contact Name | Address | | | DOB | Sex | Race | Phone |
| | | | | | | | | |

| Auto Information: | | | | | | |
|-------------------|-------|------|-------|-------|------|-----|
| Registration | State | Make | Model | Color | Year | VIN |
| | | | | | | |

| Summonses: | | | | |
|---------------|------|-----------|------|---------|
| Ticket Number | Date | Violation | Name | Officer |
| | | | | |
| | | | | |

Narrative:
 Input tchal 07 29 2017 07 01 31 Edited tchal 07 29 2017 07 01 31 BROKEN FRONT WINDOW Input tchal 07 29 2017 07 02 06 Edited tchal 07 29 2017 07 02 06 [REDACTED] MRS MOBLEY Input tchal 07 29 2017 07 02 55 Edited tchal 07 29 2017 07 02 55 CALLED IN BY A PASSERBY UNKNOWN IF ANYBODY IS INSIDE Input dcost 07 29 2017 07 07 49 Edited dcost 07 29 2017 07 07 49 BROKEN WINDOW FOUND ON THE NORTH SIDE OF THE STORE - DOES NOT APPEAR AN ENTRY WAS GAINED Input dcost 07 29 2017 07 07 55 Edited dcost 07 29 2017 07 07 55 EMPLOYEE ARRIVED ON SCENE Input dcost 07 29 2017 07 13 57 Edited dcost 07 29 2017 07 13 57 OWNER RESPONDING FROM PATERSON WITH A KEY FOR AN INTERIOR CHECK - WILL BE ABOUT FIFTEEN MINUTES Input dcost 07 29 2017 07 51 21 Edited dcost 07 29 2017 07 51 21 SEE REPORT



Teaneck Police Department

900 Teaneck Rd, Teaneck, NJ 07666

Phone: 201-837-2600 Fax: 201-837-1880 Mun. Code: 0260



Incident Report

| Incident Details: | | | Incident Location: | Disposition |
|-------------------|-------|----------|---------------------------------|------------------|
| Case Number | Time | Date | Address | Disposition |
| PD-17-027957 | 07:00 | 07/29/17 | 1364 TEANECK ROAD, TEANECK TWP, | Report Completed |

Incident Type:

Malicious Mischief

Narrative

Officer

Approving Officer

pwest

pforr

On Friday July 29 2017 Sgt. W. Croonquist P.O. R. Morales P.O. M. Spann P.O. C. Luebeck P.O. S. Batista P.O. C. Skoufas and I responded to 1364 Teaneck Road Hit City Seafood on a report of a motorist passing by the store and reporting a broken window at that address. The witness stated that they thought they had observed the actor inside of the store. Upon our arrival a perimeter was established and I observed the broken window. A check of the business revealed the front and rear door were secured and no entry had been gained into the store. An employee of the business [REDACTED] responded to the store after she was told by a friend that they had observed one of the windows broken. She contacted the owner of the store [REDACTED] who stated he would be responding from home. While waiting for [REDACTED] to respond I observed security cameras inside the store. After his arrival I asked him about the video and he informed me that he does not have the password for the security cameras and he does not know how to operate it. I informed him that if he is able to get someone to review the video and they observe the actor on video to contact police headquarters and make a copy of it. A check of the interior was conducted which showed no signs of the object that was used to break the glass and no entry was gained in the store through the window. A Victim Notification Form was completed. P.O. Percy West 299



Teaneck Police Department

900 Teaneck Rd, Teaneck, NJ 07666

Phone: 201-837-2600 Fax: 201-837-1880 Mun. Code: 0260



Incident Report

| Incident Details: | | | Incident Location: | Disposition |
|-------------------|-------|----------|---------------------------------|------------------|
| Case Number | Time | Date | Address | Disposition |
| PD-17-040720 | 15:30 | 11/07/17 | 1364 TEANECK ROAD, TEANECK TWP, | Report Completed |

| Incident Type: |
|----------------------------------|
| Request For Police Documentation |

| Narrative | Officer | Approving Officer |
|-----------|---------|-------------------|
| | rglor | dalco |

On Tuesday November 7 2017 [REDACTED] responded to police headquarters on a documentation report. [REDACTED] reported that he is the owner of Hit City Seafood 1364 Teaneck Road but rents the store from [REDACTED]. He reported that sometime between Sunday November 5 2017 at 3 00 pm and Tuesday November 7 2017 at 12 00 pm the front door locks on his store were changed and he believes that they were changed by [REDACTED]. He reported that he was not notified that the locks were going to be changed but he believes they were changed because he has not paid the rent for October and November. [REDACTED] was advised to respond to Landlord Tenant Court at 10 Main Street Hackensack New Jersey to report the incident but he advised me that his lawyer suggested that he just document the incident at the police department at this time. I called [REDACTED] but I was unable to reach her. P.O. Robert Gloria 300



Teaneck Police Department

900 Teaneck Rd, Teaneck, NJ 07666

Phone: 201-837-2600 Fax: 201-837-1880 Mun. Code: 0260



Incident Report

| Incident Details: | | | Incident Location: | Disposition |
|-------------------|-------|----------|---------------------------------|------------------|
| Case Number | Time | Date | Address | Disposition |
| PD-17-042221 | 07:56 | 11/19/17 | 1364 TEANECK ROAD, TEANECK TWP, | Report Completed |

| Incident Type: | |
|-----------------------|--|
| Burglary Forced Entry | |

| Narrative | Officer | Approving Officer |
|-----------|---------|-------------------|
| | cskou | |

On Sunday November 19 2017 at 7 56 AM Sgt P. Forrest 271 Officer West 299 Officer S. Batista 325 and I responded to 1364 Teaneck Road Hit City Seafood on a report of a front glass window broken. Upon arrival I observed the front window of the business broken and observed blood all over it. I also observed that inside business was a piece of concrete that the actor used to break the window. The front and rear door of the business was secure. We were unable to check the interior of the business due to it being very dangerous to enter through that broken window. I advised headquarters to have Bergen County Sheriff s Office of Bureau of Criminal Investigations BCI respond to process the scene. Shortly after BCI Det. Young Kim 1521 arrived on scene. He processed the scene and was able to get blood for DNA testing. Det. Kim advised that he would not submit the processing until we got verbal authorization from the Leasee. Refer to BCI Case 2017-1299 for further information. At headquarters I spoke over the phone with the owner of Hit City Seafood [REDACTED] who reported that he would give consent for the outside of the business to processed by BCI but that at this time he was in Virginia and would not be able to respond. I also advised him when he returned to the business to contact us so we could conduct an interior check of the business. Also refer to PD-17-042222 which was a burglary at 1368 Teaneck Road that occurred during the same time frame and believed to be the same actor. I also advised [REDACTED] that I would be sending his Victim Notification Form in the mail to him. I completed a Victim Notification Form and faxed it over to Bergen County Victim Witness Office P.O. Constntinos Skoufas 327.



Teaneck Police Department

900 Teaneck Rd, Teaneck, NJ 07666

Phone: 201-837-2600 Fax: 201-837-1880 Mun. Code: 0260

Incident Report



Incident Details:

| | | | | | | | | | |
|-------------|---------------|---------------|---------------|---------------|-----------------------------------|---------------|---------------|-----|-----------|
| Case Number | Time Reported | Date Reported | Time Occurred | Date Occurred | Occurrence Between Date / Time of | Time Occurred | Date Occurred | 911 | Completed |
| 19-069530 | 20:00 | 12/21/19 | 12:00 | 11/20/19 | | | | | X |

Incident Type:

Incident Location:

| | | | |
|---------------------------------|----------|--------------|---------------------------------|
| Police Information | Street # | Street Name | Intersection / Cross Street of: |
| | 1364 | Teaneck Road | W Englewood Ave / Teaneck |
| Business / Common Location Name | | | |

Contact Information: Victim Suspect Complainant Witness Driver Arrest Passenger Missing Involved Other

| | | | | | | | | |
|---------|-----------------|----|--------|-----|-----|------------|------------|-----|
| Code | Contact Name #3 | MI | Suffix | Age | Sex | Race | DOB | SSN |
| Address | | | | | | Home Phone | Cell Phone | |

| | | | | | | | | |
|---------|-----------------|----|--------|-----|-----|------------|------------|-----|
| Code | Contact Name #4 | MI | Suffix | Age | Sex | Race | DOB | SSN |
| Address | | | | | | Home Phone | Cell Phone | |

Property Information:

| | | | | | | | |
|------------------------------------|----------|---------|------|----------|------|-------|-------|
| Value of Stolen Property | Currency | Jewelry | Furs | Clothing | Auto | Misc. | Total |
| Value of Stolen Property Recovered | | | | | | | |

Automobile Information:

| 1 | Vehicle Code | Year | Make | Body Type | Model | Color | Registration | State | VIN |
|---|--------------|------|------|-----------|-------|-------|--------------|-------|-----|
| 2 | | | | | | | | | |
| 3 | | | | | | | | | |
| 4 | | | | | | | | | |

Narrative:

On Saturday, December, 21, 2019, I was assigned to the Motor Patrol Division, as the Watch Officer, while dressed in my Class B uniform.

At approximately 10:00 PM [redacted] responded to the lobby of Teaneck Police Headquarters. [redacted] stated that he was a co-owner of the [redacted] (1364 Teaneck Road). and requested to report a dispute with a contractor.

On November 20, 2019 [redacted] contacted SCM Construction NJ Inc. to remodel the restaurant's bathroom. Owner of SCM Construction NJ Inc. [redacted] provided [redacted]

| | | | | | | | | | | | | |
|-----------------------|----------|----------------------|--------|-------|-----|------|------|-----|------|------|--|--------------|
| Officer of Record: | Date: | Other Reports Filed: | | | | | | | | | | Reviewed By: |
| PO Jon-Ryan Meyer 340 | 12/21/19 | MVA | Arrest | DV | DWI | DWIQ | Tow | SD | CI | TRO | | rharvey |
| | | SHA | Prop. | Video | UOF | Prst | Supp | Juv | Bias | Pris | | |



Teaneck Police Department

900 Teaneck Rd, Teaneck, NJ 07666

Phone: 201-837-2600 Fax: 201-837-1880 Mun. Code: 0260

Incident Report



Narrative Continued (Page 2)

Case Number

19-069530

with an estimate for the work to be completed and a contract was drawn up. The contract stated that the work would begin on November 26, 2019 and would be completed by December 2, 2019. The total price of the job would be \$4000.00 and a down payment of \$2000.00 was required to begin work. The \$2000.00 balance was to be paid after the completion of the project. Both parties reviewed and signed the contract.

SCM Construction NJ Inc. began work on the bathroom of Lahore Biryani Grill. After framing a wall and performing a small amount of plumbing [REDACTED] requested [REDACTED] to pay \$500.00 to continue work. After paying [REDACTED] the additional \$500.00, SCM Construction failed to return to complete the work. [REDACTED] made several attempts to contact [REDACTED] unsuccessfully.

In order to open the restaurant, [REDACTED] hired a different construction company to complete work on the bathroom. He requested the incident be documented to prevent any further discrepancies to the extent of work completed By SCM Construction.

Officer of Record:

Date:

PO Jon-Ryan Meyer 340

12/21/19



Teaneck Police Department

900 Teaneck Rd, Teaneck, NJ 07666

Phone: 201-837-2600 Fax: 201-837-1880 Mun. Code: 0260

Incident Report



| Incident Details: | | | | | | | | | |
|-------------------|---------------|---------------|---------------|---------------|-----------------------------------|---------------|---------------|-----|-----------|
| Case Number | Time Reported | Date Reported | Time Occurred | Date Occurred | Occurrence Between Date / Time of | Time Occurred | Date Occurred | 911 | Completed |
| 21-048467 | 13:44 | 09/04/21 | 13:44 | 09/04/21 | | | | | X |

| Incident Type: | Incident Location: |
|---------------------------|---|
| Landlord / Tenant Dispute | Street # Street Name 1364 Teaneck Road Intersection / Cross Street of: Business / Common Location Name |

| Contact Information: Victim Suspect Complainant Witness Driver Arrest Passenger Missing Involved Other | | | | | | | | | |
|--|--|--|--|--|--|--|--|--|--|
| [Redacted] | | | | | | | | | |

| | | | | | | | | |
|---------|-----------------|----|--------|-----|-----|------------|------------|-----|
| Code | Contact Name #2 | MI | Suffix | Age | Sex | Race | DOB | SSN |
| Address | | | | | | Home Phone | Cell Phone | |
| Code | Contact Name #3 | MI | Suffix | Age | Sex | Race | DOB | SSN |
| Address | | | | | | Home Phone | Cell Phone | |
| Code | Contact Name #4 | MI | Suffix | Age | Sex | Race | DOB | SSN |
| Address | | | | | | Home Phone | Cell Phone | |

| Property Information: | | | | | | | |
|------------------------------------|----------|---------|------|----------|------|-------|-------|
| Value of Stolen Property | Currency | Jewelry | Furs | Clothing | Auto | Misc. | Total |
| Value of Stolen Property Recovered | | | | | | | |

| Automobile Information: | | | | | | | | | |
|-------------------------|--------------|------|------|-----------|-------|-------|--------------|-------|-----|
| 1 | Vehicle Code | Year | Make | Body Type | Model | Color | Registration | State | VIN |
| 2 | | | | | | | | | |
| 3 | | | | | | | | | |
| 4 | | | | | | | | | |

Narrative:
On Saturday, September 4, 2021, at approximately 1:44 PM, [Redacted] walked into 900 Teaneck Road (Teaneck Police Headquarters) to report an incident involving a tenant of his that currently resides at 1364 Teaneck Road.

[Redacted] reported that he is the current landlord of 1364 Teaneck Road, Teaneck, NJ 07666. He further reported that his tenant has not paid rent since the beginning of the pandemic and further caused damage to the interior of the property visible through exterior windows.

At this time, I referred [Redacted] to Landlord-tenant court located in Hackensack, New Jersey. I further

| Officer of Record: | Date: | Other Reports Filed: | Reviewed By: |
|--------------------|----------|---|--------------|
| PO Kevin Gibbs 363 | 09/04/21 | MVA Arrest DV DWI DWIQ Tow SD CI TRO SHA Prop. Video UOF Prst Supp Juv Bias Pris | pforrest |



Teaneck Police Department

900 Teaneck Rd, Teaneck, NJ 07666

Phone: 201-837-2600 Fax: 201-837-1880 Mun. Code: 0260

Incident Report



Narrative Continued (Page 2)

Case Number

21-048467

advised [REDACTED] that if he wished to sign complaints, he would have to responded to the Teaneck Municipal courts and complete the appropriate documentation.

Officer of Record:

Date:

PO Kevin Gibbs 363

09/04/21



Teaneck Police Department

900 Teaneck Rd, Teaneck, NJ 07666

Phone: 201-837-2600 Fax: 201-837-1880 Mun. Code: 0260

Incident Report



Incident Details:

| | | | | | | | | | |
|-------------|---------------|---------------|---------------|---------------|-----------------------------------|---------------|---------------|-----|-----------|
| Case Number | Time Reported | Date Reported | Time Occurred | Date Occurred | Occurrence Between Date / Time of | Time Occurred | Date Occurred | 911 | Completed |
| 22-007304 | 16:14 | 02/05/22 | 16:14 | 02/05/22 | | | | | X |

Incident Type:

Criminal Mischief 2C:17-3
Theft 2C:20-3

Incident Location:

| | | |
|---------------------------------|--------------|---------------------------------|
| Street # | Street Name | Intersection / Cross Street of: |
| 1364 | Teaneck Road | W Englewood Ave / Teaneck |
| Business / Common Location Name | | |

Contact Information: Victim Suspect Complainant Witness Driver Arrest Passenger Missing Involved Other

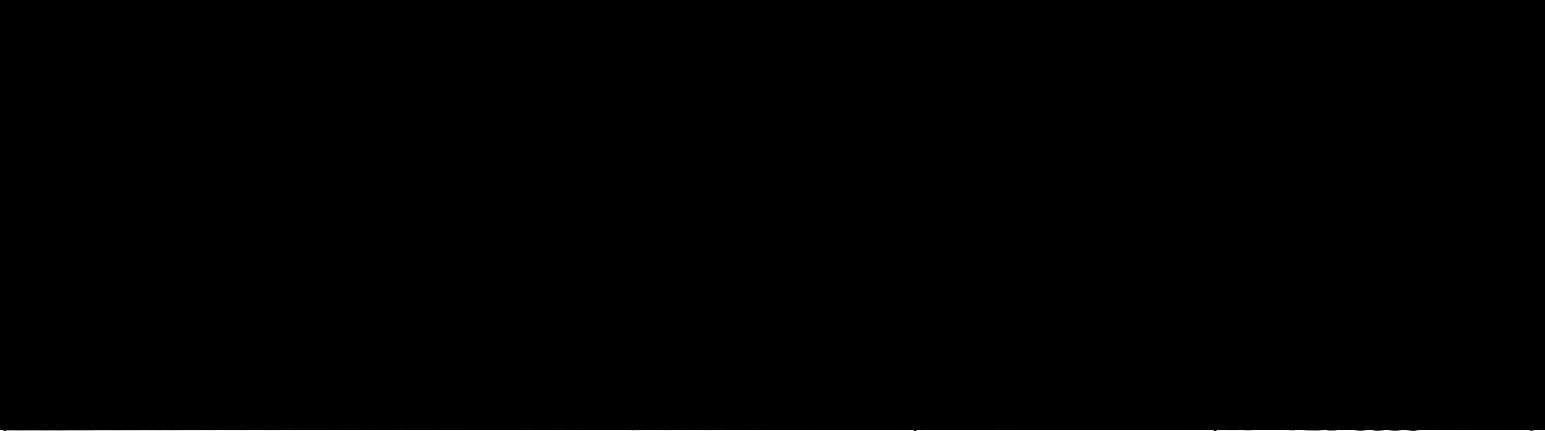

| | | | | | | | | |
|---------|-----------------|----|--------|-----|-----|------------|------------|-----|
| Code | Contact Name #4 | MI | Suffix | Age | Sex | Race | DOB | SSN |
| Address | | | | | | Home Phone | Cell Phone | |

Property Information:

| | | | | | | | |
|------------------------------------|----------|---------|------|----------|------|------------|------------|
| Value of Stolen Property | Currency | Jewelry | Furs | Clothing | Auto | Misc. | Total |
| | | | | | | \$8,610.00 | \$8,610.00 |
| Value of Stolen Property Recovered | | | | | | | |

Automobile Information:

| 1 | Vehicle Code | Year | Make | Body Type | Model | Color | Registration | State | VIN |
|---|--------------|------|------|-----------|-------|-------|--------------|-------|-----|
| 2 | | | | | | | | | |
| 3 | | | | | | | | | |
| 4 | | | | | | | | | |

Narrative:

On Saturday, February, 5, 2022, at approximately 4:14 P.M., I responded to the vacant restaurant located at 1364 Teaneck Road, on a report of criminal mischief. I responded with my vehicle Mobile Video Recorder (MVR) activated.

Upon my arrival, I was met by the landlord of the vacant restaurant, [REDACTED] and her son [REDACTED]. [REDACTED] had some difficulties communicating in English. As a result [REDACTED] assisted her with translating. They reported that their last tenant was evicted and took various appliances that belonged to the building. They further reported the restaurant's bathroom was damaged. As a result of these circumstances, they were advised by their attorney to file a police report for future

| | | | | | | | | | | | | |
|---------------------------|--------------|-----------------------------|--------|-------|-----|------|------|-----|------|------|--|---------------------|
| Officer of Record: | Date: | Other Reports Filed: | | | | | | | | | | Reviewed By: |
| PO Brandon Graham | 354 02/05/22 | MVA | Arrest | DV | DWI | DWIQ | Tow | SD | CI | TRO | | jgarland |
| | | SHA | Prop. | Video | UOF | Prst | Supp | Juv | Bias | Pris | | |



Teaneck Police Department

900 Teaneck Rd, Teaneck, NJ 07666

Phone: 201-837-2600 Fax: 201-837-1880 Mun. Code: 0260

Incident Report



Narrative Continued (Page 2)

Case Number

22-007304

legal action against the tenant.

They reported that the evicted tenant, [REDACTED], opened a Krispy Krunchy Chicken Restaurant. After several months of rent that was not paid and litigation in courts, [REDACTED] was forced to close his business and left the restaurant in August, or September of 2021. Due to legal issues with the eviction, the Im's were unable to gain access to the building until February 2, 2022.

Upon inspecting the restaurant grounds, debris and trash could be found all over the floors. There were also open wires from the ceiling, that appeared to be where missing light fixtures were located. The sliding doors located in the back of a deli style refrigerator were also missing.

The restaurant's bathroom walls appeared to be severely damaged. Tiling that was torn off the walls were located on the floor. There were also multiple holes in the walls, that appeared to have been hit by a blunt object. There was a damaged ceiling vent that was hanging by a wire. The Im's did not know how much it would cost to repair the bathroom, however it is estimated the repairs would cost approximately \$5000.00.

In addition to the damage to the bathroom, the Young's reported several appliance items that they believed Mr. Ahmad took from the restaurant. The following items were reported missing:

- Approximately 5 lighting fixtures \$30 each
- Ice Machine \$1000
- Refrigerator \$1000
- Exterior Screen Door \$600
- Lobster Tank \$5000
- Coffee Machine \$400
- Ladder \$200
- Two(2) Faucets \$80 each
- Celler Door Lock \$100

The estimated total value of the missing items was \$8,610.00

Sgt. R Boswell #308 arrived on scene to assist with the investigation.

[REDACTED] was provided a Victim Notification Form (VNF) for Criminal Mischief in regard to damages done to the bathroom. That form has been added to this report as digital media. Five(5) pictures of the interior of the restaurant were taken and added to the Beast as evidence.

Officer of Record:

Date:

PO Brandon Graham 354

02/05/22



Teaneck Police Department

900 Teaneck Rd, Teaneck, NJ 07666

Phone: 201-837-2600 Fax: 201-837-1880 Mun. Code: 0260

Incident Report



Narrative Continued (Page 3)

Case Number

22-007304

The [REDACTED] were advised that the missing items would be documented in this report to aide in further civil court actions against [REDACTED]

Officer of Record:

Date:

PO Brandon Graham 354

02/05/22



Teaneck Police Department

900 Teaneck Rd, Teaneck, NJ 07666

Phone: 201-837-2600 Fax: 201-837-1880 Mun. Code: 0260

Incident Report



Incident Details:

| | | | | | | | | | |
|-------------|---------------|---------------|---------------|---------------|-----------------------------------|---------------|---------------|-----|-----------|
| Case Number | Time Reported | Date Reported | Time Occurred | Date Occurred | Occurrence Between Date / Time of | Time Occurred | Date Occurred | 911 | Completed |
| 18-023085 | 15:02 | 06/01/18 | 15:02 | 06/01/18 | | | | X | X |

Incident Type:

Disturbance / Noise Complaint
Theft 2C:20-3

Incident Location:

Street # Street Name Intersection / Cross Street of:
1358 Teaneck Road Teaneck Road / W

Business / Common Location Name
Ana's Beauty Salon

Contact Information: Victim Suspect Complainant Witness Driver Arrest Passenger Missing Involved Other

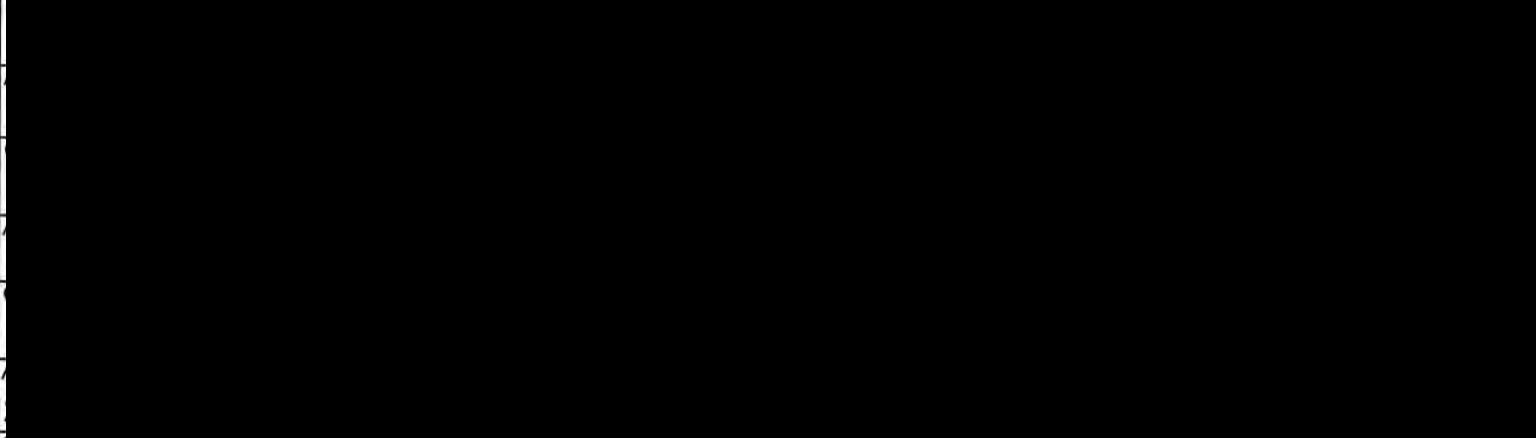

| | | | | | | | | |
|---------|-----------------|----|--------|-----|-----|------------|-----|------------|
| Code | Contact Name #4 | MI | Suffix | Age | Sex | Race | DOB | SSN |
| Address | | | | | | Home Phone | | Cell Phone |

Property Information:

| | | | | | | | |
|------------------------------------|----------|---------|------|----------|------|-------|----------|
| Value of Stolen Property | Currency | Jewelry | Furs | Clothing | Auto | Misc. | Total |
| | \$380.00 | | | | | | \$380.00 |
| Value of Stolen Property Recovered | | | | | | | |

Automobile Information:

| 1 | Vehicle Code | Year | Make | Body Type | Model | Color | Registration | State | VIN |
|---|--------------|------|------|-----------|-------|-------|--------------|-------|-----|
| 2 | | | | | | | | | |
| 3 | | | | | | | | | |
| 4 | | | | | | | | | |

Narrative:

On Friday, June 1, 2018, at approximately 3:02 PM, P.O. Batista #325 and I responded to 1358 Teaneck Road, Ana's Beauty Salon, on the report of a customer dispute.

Upon arrival, we met [REDACTED] the owner of the salon. She reported that a lady, later identified as [REDACTED] walked in and requested to use the bathroom. After using the bathroom [REDACTED] left the area. She reported that approximately twenty five minutes later [REDACTED] called the salon advising that she left her wallet there and was coming back for it. [REDACTED] reported that the only other woman to enter the bathroom after [REDACTED] was [REDACTED] who stayed to speak with the police.

| | | | | | | | | | | | | |
|---------------------------|--------------|-----------------------------|--------|-------|-----|------|--------|-----|------|------|--|---------------------|
| Officer of Record: | Date: | Other Reports Filed: | | | | | | | | | | Reviewed By: |
| PO Patrick Haase 341 | 06/01/18 | MVA | Arrest | DV | DWI | DWIQ | Tow | SD | CI | TRO | | ttully |
| | | SHA | Prop. | Video | UOF | Prst | Supp 1 | Juv | Bias | Pris | | |



Teaneck Police Department

900 Teaneck Rd, Teaneck, NJ 07666

Phone: 201-837-2600 Fax: 201-837-1880 Mun. Code: 0260

Incident Report



Narrative Continued (Page 2)

Case Number

18-023085

██████████ reported that she had just withdrawn \$380.00 from an ATM, in increments of \$20 dollar bills. She reported that she was having stomach issues and need to use the bathroom, so she used the one at Ana's Beauty Salon. She reported that she mistakenly left he wallet inside the bathroom prior to leaving the area. She reported that when she got to the Anderson Street Bridge in Hackensack, NJ, she notice her wallet wasn't in her purse and headed back to the salon. She reported that he wallet was exactly where she left it but the \$380.00 was missing. She did have \$10.00 in change still in the wallet when I inspected it.

██████████ reported that she was the only other person to enter the bathroom after ██████████ but didn't notice the wallet in the brief amount of time she was in there. She reported that she didn't touch the wallet or take the money. She offered to let me inspect her wallet and purse. She had cash in her wallet but no \$20 dollar bills.

After ██████████ realized I wasn't going to arrest anyone immediately and was still conducting my investigation, she decided she wasn't going to continue any further with a report and left before I was able to fill out a Victim Notification Form. ██████████ requested that the incident be documented due to Ms. ██████████ hostile nature and attitude, prior to police arrival.

Reporting Officer: Patrick Haase #341.

Officer of Record:

Date:

PO Patrick Haase 341

06/01/18



Teaneck Police Department

900 Teaneck Rd, Teaneck, NJ 07666

Phone: 201-837-2600 Fax: 201-837-1880 Mun. Code: 0260

Incident Report



Incident Details:

| | | | | | | | | | |
|-------------|---------------|---------------|---------------|---------------|-----------------------------------|---------------|---------------|-----|-----------|
| Case Number | Time Reported | Date Reported | Time Occurred | Date Occurred | Occurrence Between Date / Time of | Time Occurred | Date Occurred | 911 | Completed |
| 18-064374 | 01:49 | 12/29/18 | 01:49 | 12/29/18 | | | | | X |

Incident Type:

Unsecured Building

Incident Location:

Street # Street Name Intersection / Cross Street of:
 1356 Teaneck Road Teaneck Road / Garden St
 Business / Common Location Name

Contact Information: Victim Suspect Complainant Witness Driver Arrest Passenger Missing Involved Other

| Code | Contact Name #1 | MI | Suffix | Age | Sex | Race | DOB | SSN |
|---------|-----------------|----|--------|-----|-----|------------|-----|------------|
| | | | | | | | | |
| Address | | | | | | Home Phone | | Cell Phone |
| | | | | | | | | |
| Address | | | | | | Home Phone | | Cell Phone |
| | | | | | | | | |
| Address | | | | | | Home Phone | | Cell Phone |
| | | | | | | | | |
| Address | | | | | | Home Phone | | Cell Phone |

Property Information:

| Value of Stolen Property | Currency | Jewelry | Furs | Clothing | Auto | Misc. | Total |
|------------------------------------|----------|---------|------|----------|------|-------|-------|
| | | | | | | | |
| Value of Stolen Property Recovered | | | | | | | |

Automobile Information:

| 1 | Vehicle Code | Year | Make | Body Type | Model | Color | Registration | State | VIN |
|---|--------------|------|------|-----------|-------|-------|--------------|-------|-----|
| 2 | | | | | | | | | |
| 3 | | | | | | | | | |
| 4 | | | | | | | | | |

Narrative:

On Saturday, December 19, 2018, at approximately 1:49 AM, while conducting a physical business check I noticed the front door to 1356 Teaneck Road (old H&R Liquors) was unlocked. Officer Powers #337 and Officer Hoover #339 then responded.

An interior check of the store was conducted with negative results and nothing seemed disturbed and there did not appear to be forced entry. The front door was secured. It should be noted that the store is vacant.

Report Submitted by: PO Michael Spann #344

Officer of Record: Date: Other Reports Filed: Reviewed By:

| | | | |
|----------------------|----------|---|---------|
| PO Michael Spann 344 | 12/29/18 | MVA Arrest DV DWI DWIQ Tow SD CI TRO | gwright |
| | | SHA Prop. Video UOF Prst Supp Juv Bias Pris | |

| | | | | | | | | | | | | | | | | | | | | | | | | | |
|------------|--|----|---|-----|--|----|---|-----------------------|--|-----------------------------------|------------------------|---|---|---|-------------------|-------------|------------|--|----------|--|---------------|--|-----------|--|-------------|
| 06 05 | Page 1 of 2 <input type="checkbox"/> Fatal | | New Jersey Police Crash Investigation Report | | | | | | | | | | <input checked="" type="checkbox"/> Reportable <input type="checkbox"/> Non-Reportable <input type="checkbox"/> Change Report | | | 118a 25 | | | | | | | | | |
| 07 01 | 1. Case Number 19-043275 | | 10. Crash Occurred On: 1356 Teaneck Road S | | | | | 11. Speed Limit 30 | | 12. Route No. Suffix 13. Milepost | | | 18. Speed Limit 25 | | | 118b --- | | | | | | | | | |
| 08 01 | 2. Police Dept. of Teaneck | | Code 01 | | Road Name W Englewood Ave | | | | | 18. Speed Limit 25 | | | 119a 02 | | | | | | | | | | | | |
| 09 05 | 3. Station/Precinct 100 | | <input type="checkbox"/> At Intersection with | | <input type="checkbox"/> Feet | | <input checked="" type="checkbox"/> Miles | | 19. To: 17. Cross Road Name/Route No. Ramp From: - | | | <input type="checkbox"/> NB <input type="checkbox"/> EB <input type="checkbox"/> SB <input type="checkbox"/> WB | | | 119b --- | | | | | | | | | | |
| 10a 01 | 4. Date of Crash mm dd yy 08 08 19 | | 5. Day of Week Su M Tu W F Sa | | 6. Time (use 2400 hrs.) 17:26 | | 7. Municipality Code 0260 | | 8. Total Killed 00 | | 9. Total Injured 00 | | 21. Latitude 20. Route Name/Route No. 22. Longitude | | | 120a --- | | | | | | | | | |
| 100b 04 | 23. Veh. # 24. Policy No. 1 4497-09-70-24 | | 25. NJ Ins. Code 100 | | 53. Veh. # 54. Policy No. 2 4489-20-54-60 | | 65. NJ Ins. Code 100 | | <input checked="" type="checkbox"/> Parked <input type="checkbox"/> Ped <input type="checkbox"/> Pedalcyclist <input type="checkbox"/> Resp. to Emergency <input type="checkbox"/> Hit & Run | | | <input type="checkbox"/> Parked <input type="checkbox"/> Ped <input type="checkbox"/> Pedalcyclist <input type="checkbox"/> Resp. to Emergency <input type="checkbox"/> Hit & Run | | | 120b --- | | | | | | | | | | |
| 101 02 | 28. Driver's First Name Initial Last Name | | | | 29. Sex | | 58. Driver's First Name Initial Last Name | | | | 59. Sex | | 121a 01 | | | | | | | | | | | | |
| 102 01 | 27. Number & Street | | | | 57. Number & Street | | | | 121b --- | | | | | | | | | | | | | | | | |
| 103 01 | 28. City State Zip | | | | 58. City State Zip | | | | 122 10 | | | | | | | | | | | | | | | | |
| 104 02 | 30. Eyes DL Class Restrictions Endorsements 31. State | | | | 60. Eyes DL Class Restrictions Endorsements 61. State | | | | 123 01 | | | | | | | | | | | | | | | | |
| 105 06 | 32. Driver's License Number | | | | 33. DOB mm dd yy | | 34. Expires mm yy | | 62. Driver's License Number | | | | 63. DOB mm dd yy | | 64. Expires mm yy | | 124 11 | | | | | | | | |
| 106 --- | 35. Owner's First Name Initial Last Name | | | | 65. Owner's First Name Initial Last Name | | | | 125 11 | | | | | | | | | | | | | | | | |
| 107 --- | 36. Number & Street | | | | 68. Number & Street | | | | 126a 26 | | | | | | | | | | | | | | | | |
| 108 01 | 37. City State Zip | | | | 67. City State Zip | | | | 126b --- | | | | | | | | | | | | | | | | |
| 109 01 | 38. Make | | 39. Model | | 40. Color | | 41. Year | | 42. Plate No. | | 43. State | | 68. Make | | 69. Model | | 70. Color | | 71. Year | | 72. Plate No. | | 73. State | | 126c --- |
| 110 01 | 44. VIN | | | | 45. Expires | | 74. VIN | | | | 75. Expires | | 126d --- | | | | | | | | | | | | |
| 111 01 | 46. Vehicle Removed to: | | | | 78. Vehicle Removed to: | | | | 126e 26 | | | | | | | | | | | | | | | | |
| 112 --- | <input checked="" type="checkbox"/> Driven <input type="checkbox"/> Towed Disabled <input type="checkbox"/> Towed Disabled & Impounded | | | | <input checked="" type="checkbox"/> Driven <input type="checkbox"/> Towed Disabled <input type="checkbox"/> Towed Disabled & Impounded | | | | 127a 28 | | | | | | | | | | | | | | | | |
| 113 --- | <input type="checkbox"/> Left at Scene <input type="checkbox"/> Towed Impounded | | | | <input type="checkbox"/> Left at Scene <input type="checkbox"/> Towed Impounded | | | | 127b --- | | | | | | | | | | | | | | | | |
| 114 --- | 47. Authority | | | | 77. Authority | | | | 127c --- | | | | | | | | | | | | | | | | |
| 115 --- | <input checked="" type="checkbox"/> Owner <input type="checkbox"/> Driver <input type="checkbox"/> Police | | | | <input type="checkbox"/> Owner <input checked="" type="checkbox"/> Driver <input type="checkbox"/> Police | | | | 127d --- | | | | | | | | | | | | | | | | |
| 116 03 | 48. Alcohol Drug Test | | | | 49. Hazardous Material | | | | 78. Alcohol Drug Test | | | | 79. Hazardous Material | | | | 127e 28 | | | | | | | | |
| 117 03 | Given: <input checked="" type="checkbox"/> No <input type="checkbox"/> Yes <input type="checkbox"/> Refused | | | | Given: <input checked="" type="checkbox"/> None <input type="checkbox"/> On Board <input type="checkbox"/> Spill | | | | Given: <input checked="" type="checkbox"/> No <input type="checkbox"/> Yes <input type="checkbox"/> Refused | | | | Given: <input type="checkbox"/> None <input type="checkbox"/> On Board <input type="checkbox"/> Spill | | | | 128 26 | | | | | | | | |
| | Type: <input type="checkbox"/> Breath <input type="checkbox"/> Blood <input type="checkbox"/> Urine | | | | Type: <input type="checkbox"/> Breath <input type="checkbox"/> Blood <input type="checkbox"/> Urine | | | | Type: <input type="checkbox"/> Breath <input type="checkbox"/> Blood <input type="checkbox"/> Urine | | | | Type: <input type="checkbox"/> Breath <input type="checkbox"/> Blood <input type="checkbox"/> Urine | | | | 129 09 | | | | | | | | |
| | Results: 0.00% <input type="checkbox"/> Pending | | | | Hazard Class Placard No. | | | | Results: 0.00% <input type="checkbox"/> Pending | | | | Hazard Class Placard No. | | | | 130 09 | | | | | | | | |
| | 60. Carrier No. | | | | 61. GVWR / GCWR (trucks & buses only) | | | | 80. Carrier No. | | | | 81. GVWR / GCWR (trucks & buses only) | | | | 131 03 | | | | | | | | |
| | <input type="checkbox"/> USDOT <input type="checkbox"/> None | | | | <input type="checkbox"/> ≤ 10,000 lbs. <input type="checkbox"/> 10,001 - 26,000 lbs. <input type="checkbox"/> ≥ 26,001 lbs. | | | | <input type="checkbox"/> USDOT <input type="checkbox"/> None | | | | <input type="checkbox"/> ≤ 10,000 lbs. <input type="checkbox"/> 10,001 - 26,000 lbs. <input type="checkbox"/> ≥ 26,001 lbs. | | | | 132 03 | | | | | | | | |
| | 62. Motor Carrier or Government Entity | | | | 62. Motor Carrier or Government Entity | | | | 62. Motor Carrier or Government Entity | | | | 62. Motor Carrier or Government Entity | | | | 133 02 | | | | | | | | |
| | Number & Street | | | | Number & Street | | | | Number & Street | | | | Number & Street | | | | 134 02 | | | | | | | | |
| | City State Zip | | | | City State Zip | | | | City State Zip | | | | City State Zip | | | | | | | | | | | | |
| | 135. Damage to Other Property <input type="checkbox"/> Yes (if Yes, describe) <input checked="" type="checkbox"/> No | | | | | | | | | | | | | | | | | | | | | | | | |
| | Oper. 136. Charge | | 137. Summons No. | | Oper. 138. Charge | | 139. Summons No. | | Oper. 140. Charge | | 141. Summons No. | | Oper. 142. Charge | | 143. Summons No. | | | | | | | | | | |
| | | | | | | | | | | | | | | | | | | | | | | | | | |
| A | 83 | 84 | 85 | 86 | 87 | 88 | 89 | 90 | 91 | 92 | 93 | 94 | 95 | Names & Addresses of Occupants If Deceased, Date & Time of Death | | | | | | | | | | | |
| B | 2 | 01 | 01 | --- | 19 | M | --- | --- | 11 | 04 | --- | --- | Taylor, Trey-1491 Endicott Terrace, Teaneck, NJ 07666-6031 | | | | | | | | | | | | |
| C | | | | | | | | | | | | | | | | | | | | | | | | | |
| D | | | | | | | | | | | | | | | | | | | | | | | | | |

New Jersey Police
Crash Investigation Report

Case Number
19-043275

Page 2 of 2

| | 83 | 84 | 85 | 86 | 87 | 88 | 89 | 90 | 91 | 92 | 93 | 94 | 95 | Names & Addresses of Occupants If Deceased, Date & Time of Death |
|---|-----|-----|-----|-----|-----|-----|-----|-----|-----|-----|-----|-----|-----|---|
| E | --- | --- | --- | --- | --- | --- | --- | --- | --- | --- | --- | --- | --- | ----- |
| F | --- | --- | --- | --- | --- | --- | --- | --- | --- | --- | --- | --- | --- | ----- |
| G | --- | --- | --- | --- | --- | --- | --- | --- | --- | --- | --- | --- | --- | ----- |
| H | --- | --- | --- | --- | --- | --- | --- | --- | --- | --- | --- | --- | --- | ----- |
| I | --- | --- | --- | --- | --- | --- | --- | --- | --- | --- | --- | --- | --- | ----- |
| J | --- | --- | --- | --- | --- | --- | --- | --- | --- | --- | --- | --- | --- | ----- |

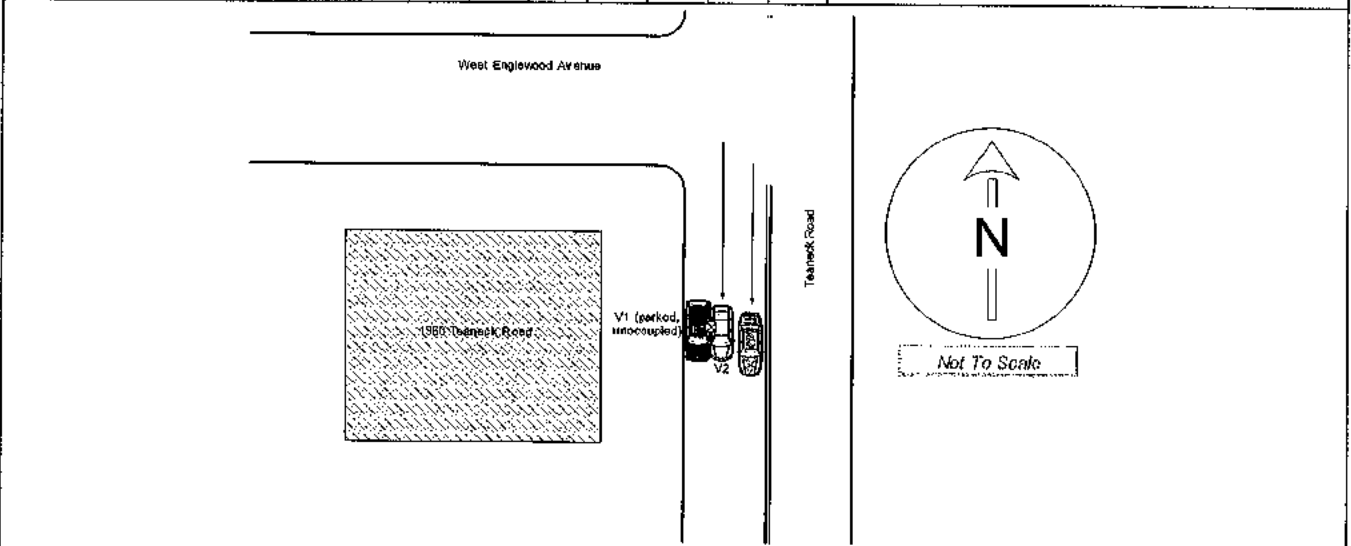

146. Crash Description/Narrative

The Owner of Vehicle 1 stated that he was returning to his vehicle after patronizing a nearby business when he observed a white sedan sideswipe his vehicle, which was parked in front of the address of 1356 Teaneck Road and unoccupied. He was unable to determine the make/model of the Vehicle 2 at the time of the collision. *Vehicle 2 did not remain on scene.

The Driver of Vehicle 2 reported that he was traveling southbound on Teaneck Road, having just passed through the intersection with West Englewood Avenue. He stated that he was traveling next to an uninvolved third vehicle while attempting to merge into the traffic lane. He further stated that he believed he had enough room to remain next to the adjacent third vehicle without being in danger of striking any of the parked vehicles in front of 1356 Teaneck Road. He was unaware that he had struck another vehicle until he returned home and observed damage located on the passenger side of his vehicle.

*After observing the damage to his vehicle, The Driver of Vehicle 2 responded to Teaneck Police Department to report the incident. He provided the necessary paperwork to document the collision. This information was relayed to me by the Watch Officer who spoke with him.

146. Officer's Signature

PO Kevin Florio 349

147. Badge #

349

148. Reviewer

Lt. Douglas Alcott 258

Badge #

258

149. Case Status

Pending Complete



Teaneck Police Department

900 Teaneck Rd, Teaneck, NJ 07666

Phone: 201-837-2600 Fax: 201-837-1880 Mun. Code: 0260

Incident Report



Incident Details:

| | | | | | | | | | |
|-------------|---------------|---------------|---------------|---------------|-----------------------------------|---------------|---------------|-----|-----------|
| Case Number | Time Reported | Date Reported | Time Occurred | Date Occurred | Occurrence Between Date / Time of | Time Occurred | Date Occurred | 911 | Completed |
| 21-059477 | 15:13 | 10/26/21 | 15:13 | 10/26/21 | | | | X | X |

Incident Type:

Harassment 2C:33-4

Incident Location:

Street # Street Name Intersection / Cross Street of:
 1356 Teaneck Road Teaneck Road / Garden St
 Business / Common Location Name

Contact Information: Victim Suspect Complainant Witness Driver Arrest Person Medical Contact Other

[Redacted Contact Information]

| | | | | | | | | |
|---------|-----------------|----|--------|-----|-----|------------|------------|-----|
| Code | Contact Name #3 | MI | Suffix | Age | Sex | Race | DOB | SSN |
| Address | | | | | | Home Phone | Cell Phone | |
| Code | Contact Name #4 | MI | Suffix | Age | Sex | Race | DOB | SSN |
| Address | | | | | | Home Phone | Cell Phone | |

Property Information:

| | | | | | | | |
|------------------------------------|----------|---------|------|----------|------|-------|-------|
| Value of Stolen Property | Currency | Jewelry | Furs | Clothing | Auto | Misc. | Total |
| Value of Stolen Property Recovered | | | | | | | |

Automobile Information:

| 1 | Vehicle Code | Year | Make | Body Type | Model | Color | Registration | State | VIN |
|---|--------------|------|------|-----------|-------|-------|--------------|-------|-------------------|
| | Veh. 1 | 15 | BMW | 4 DR | 328 | WH | R46LTF | NJ | WBA3B5C51FF960930 |
| 2 | | | | | | | | | |
| 3 | | | | | | | | | |
| 4 | | | | | | | | | |

Narrative:

On Tuesday, October 26, 2021, at approximately 3:13 AM, [Redacted] walked into headquarters to report an incident of harassment at 1356 Teaneck Road, the Reggae Kitchen restaurant. She reported while at the counter a six foot two, black male rudely reached over her shoulder, after that words were exchanged between the two and the male party reported he was going to have his wife come. [Redacted] took that as a threat and called 9-1-1. She stated that the male party then walked outside to her vehicle and started taking pictures of her license plate and vehicle before leaving. She stated it took too long for police to respond so she decided to come to police headquarters. A copy of [Redacted] written statement was scanned into lawsoft and attached to the report.

| | | | | | | | | | | | | |
|---------------------------|--------------|-----------------------------|--------|-------|-----|------|------|-----|------|------|--|---------------------|
| Officer of Record: | Date: | Other Reports Filed: | | | | | | | | | | Reviewed By: |
| PO Patrick Haase 341 | 10/26/21 | MVA | Arrest | DV | DWI | DWIQ | Tow | SD | CI | TRO | | ttully |
| | | SHA | Prop. | Video | UOF | Prst | Supp | Juv | Bias | Pris | | |



Teaneck Police Department

900 Teaneck Rd, Teaneck, NJ 07666

Phone: 201-837-2600 Fax: 201-837-1880 Mun. Code: 0260

Incident Report



Incident Details:

| | | | | | | | | | |
|-------------|---------------|---------------|---------------|---------------|-----------------------------------|---------------|---------------|-----|-----------|
| Case Number | Time Reported | Date Reported | Time Occurred | Date Occurred | Occurrence Between Date / Time of | Time Occurred | Date Occurred | 911 | Completed |
| 18-062804 | 23:29 | 12/19/18 | 23:29 | 12/19/18 | | | | | X |

Incident Type:

Criminal Mischief 2C:17-3

Incident Location:

Street # Street Name Intersection / Cross Street of:
 1354 Teaneck Road Teaneck Road / Garden St
 Business / Common Location Name

Contact Information: Victim Suspect Complainant Witness Driver Arrest Passenger Missing Involved Other



Property Information:

| Value of Stolen Property | Currency | Jewelry | Furs | Clothing | Auto | Misc. | Total |
|------------------------------------|----------|---------|------|----------|------|-------|-------|
| Value of Stolen Property Recovered | | | | | | | |

Automobile Information:

| 1 | Vehicle Code | Year | Make | Body Type | Model | Color | Registration | State | VIN |
|---|--------------|------|------|-----------|-------|-------|--------------|-------|-----|
| 2 | | | | | | | | | |
| 3 | | | | | | | | | |
| 4 | | | | | | | | | |

Narrative:

On Wednesday, December 19, 2018, at approximately 11:29 PM, Officer Hoover #339 and I responded to 1354 Teaneck Road (Reggae Kitchen) on a report of the front window and front glass door being broken.

Upon my arrival the owner of the restaurant [redacted] was waiting outside. The front window of the restaurant was broken and the entrance door to the restaurant was shattered [redacted] and worker, [redacted] then arrived on scene. [redacted] stated he locked up the restaurant at approximately 10:30 P.M. that evening and that there was no one that he could think of that would have broken the window and door.

| | | | |
|---------------------------|--------------|---|---------------------|
| Officer of Record: | Date: | Other Reports Filed: | Reviewed By: |
| PO Michael Spann 344 | 12/19/18 | MVA Arrest 1 DV DWI DWIQ Tow SD CI TRO SHA Prop. Video UOF Prst Supp 1 Juv Bias Pris | gwright |



Teaneck Police Department

900 Teaneck Rd, Teaneck, NJ 07666

Phone: 201-837-2600 Fax: 201-837-1880 Mun. Code: 0260

Incident Report



Narrative Continued (Page 2)

Case Number

18-062804

I then asked [REDACTED] if they had an idea on who would have committed the crime and [REDACTED] stated it could possible be her aunt [REDACTED] as she's been having ongoing issues with her.

Before making entry into the restaurant I noticed a hammer with an black handle/ orange middle/silver top, on the inside of the restaurant approximately one foot from the doorway. The door was locked and no entry was made into the restaurant.

[REDACTED] then unlocked the door and Officer Hoover and I conducted an interior check of the restaurant with negative results.

[REDACTED] was then able to retrieve video footage of the incident on the store cameras, with the outside camera facing north on Teaneck Road having the best angle of the incident. At approximately 11:00 PM, the video footage shows a black female wearing a winter coat with fur on the hood walk up to the door from the south side of the store. The female then proceeded to swing an object with her right hand towards the window and door. The Female that walked back south of the restaurant.

[REDACTED] then stated that the female in the video was her aunt [REDACTED] and that she resides in Hackensack.

[REDACTED] was not able to make a copy of the video at that particular time but she would provide a copy of the video at a later date.

The window and glass door were secured and cardboard was placed there for the time being until the glass could be replaced.

The hammer used at the scene was placed in a paper bag, logged into evidence, and placed into Locker #114 on Thursday December 20, 2018, at approximately 1:30 AM.

On Thursday, December 20, 2018, [REDACTED] was able to retrieve footage of the incident from 1352 Teaneck Road (H&R Liquars). The flash drive containing the video footage was logged into evidence and placed in Locker #114 on Friday, December 21, 2018.

A Victim Notification Form was completed and signed by [REDACTED] It was later faxed to the Office of Victim Witness Advocacy.

Report Submitted by: PO Michael Spann #344

Officer of Record:

Date:

PO Michael Spann 344

12/19/18



Teaneck Police Department

900 Teaneck Rd, Teaneck, NJ 07666

Phone: 201-837-2600 Fax: 201-837-1880 Mun. Code: 0260

Incident Report



Incident Details:

| | | | | | | | | | |
|-------------|---------------|---------------|---------------|---------------|-----------------------------------|---------------|---------------|-----|-----------|
| Case Number | Time Reported | Date Reported | Time Occurred | Date Occurred | Occurrence Between Date / Time of | Time Occurred | Date Occurred | 911 | Completed |
| 19-010116 | 21:21 | 02/21/19 | 20:30 | 02/21/19 | | | | | X |

| | | | |
|---------------------------------|----------------------------|---|-----------------------------|
| Incident Type: | | Incident Location: | |
| Harassment 2C:33-4 | Domestic Violence 2C:25-21 | Street # 1354 | Street Name Teaneck Road |
| | | Intersection / Cross Street of: Teaneck Road / Garden St | |
| Business / Common Location Name | | | |

| Contact Information: | | | | | | | | | |
|----------------------|-----------------|-------------|---------|--------|--------|-----------|---------|----------|-------|
| Victim | Suspect | Complainant | Witness | Driver | Arrest | Passenger | Missing | Involved | Other |
| Code | Contact Name #1 | MI | Suffix | Age | Sex | Race | DOB | SSN | |

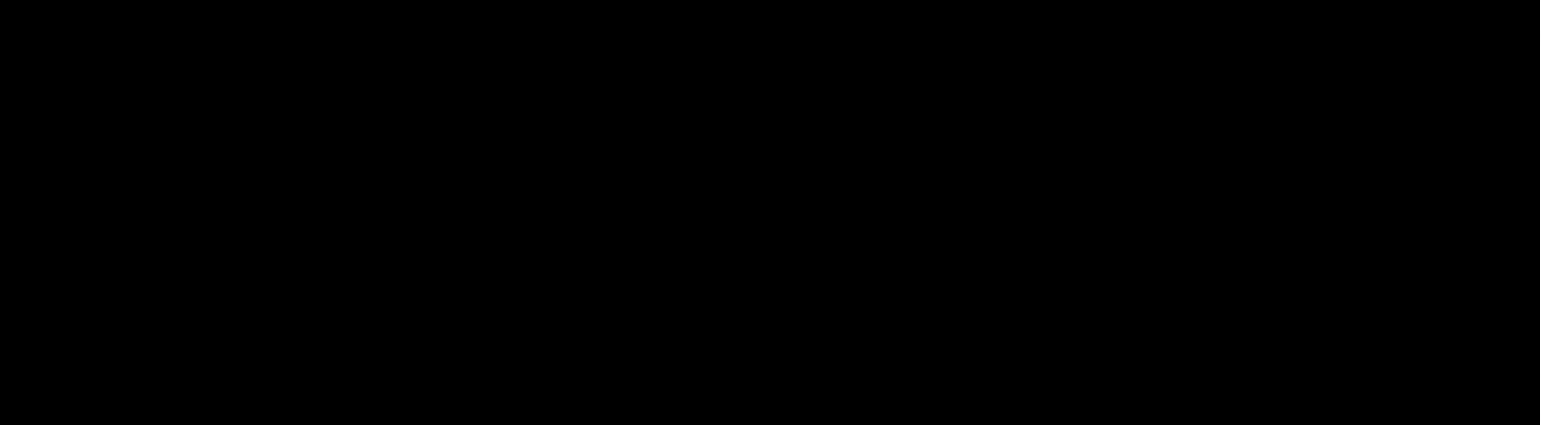

| | | | | | | | | |
|---------|-----------------|----|--------|-----|-----|------------|-----|------------|
| Code | Contact Name #1 | MI | Suffix | Age | Sex | Race | DOB | SSN |
| Address | | | | | | Home Phone | | Cell Phone |

Property Information:

| Value of Stolen Property | Currency | Jewelry | Furs | Clothing | Auto | Misc. | Total |
|------------------------------------|----------|---------|------|----------|------|-------|-------|
| Value of Stolen Property Recovered | | | | | | | |

Automobile Information:

| 1 | Vehicle Code | Year | Make | Body Type | Model | Color | Registration | State | VIN |
|---|--------------|------|------|-----------|-------|-------|--------------|-------|-----|
| 2 | | | | | | | | | |
| 3 | | | | | | | | | |
| 4 | | | | | | | | | |

Narrative:

On Thursday, February 21, 2019, at approximately 9:21 PM, I responded to 1354 Teaneck Rd (Reggae Kitchen Restaurant), on a report of a possible violation of a Temporary Restraining Order (TRO).

Upon arrival, I spoke with the caller [REDACTED] reported that on this date, at approximately 8:30 PM, she received a text message from her brother, [REDACTED] the text message contained a picture of a social media post, reported to be published on the Facebook profile of her aunt, [REDACTED] became alarmed by the post, due to the nature of the statements and the fact that her home address was included in the post.

| Officer of Record: | Date: | Other Reports Filed: | | | | | | | | | | Reviewed By: |
|----------------------|----------|----------------------|--------|-------|-----|------|------|-----|------|------|-----|--------------|
| PO Antherson Ramirez | 02/21/19 | MVA | Arrest | DV | 1 | DWI | DWIQ | Tow | SD | CI | TRO | kmarrero |
| | | SHA | Prop. | Video | UOF | Prst | Supp | Juv | Bias | Pris | | |



Teaneck Police Department

900 Teaneck Rd, Teaneck, NJ 07666

Phone: 201-837-2600 Fax: 201-837-1880 Mun. Code: 0260

Incident Report



Narrative Continued (Page 2)

Case Number

19-010116

██████████ advised me that a Temporary Restraining Order (TRO) against ██████████ was in effect, prohibiting ██████████ from any direct oral, written, electronic, or personal contact with her. ██████████ further reported that she is very concerned about the post, due to similar incidents that have been reported in the past, in which ██████████ posted threatening statements on social media, and later damaged property at her store. See Case #18-059893 and Case #18-062804, for further information.

██████████ provided me with a copy of the media post picture, to my work e-mail. The post referred to Ms. ██████████ getting revenge and included her home address. It did not mention ██████████ specifically, but made references to her business of Reggae Kitchen and her home address with profanities. Please refer to attached photo regarding the post for specifics. ██████████ advised that she would be retrieving a copy of the TRO and responding to Teaneck Police Headquarters.

Once at headquarters, a Domestic Violence Central Registry (DVCR) computer inquiry confirmed that TRO Docket Num ██████████ was in-effect. An open search query of ██████████ Facebook profile was also conducted, however, the post received by ██████████ could not be located. Due to the fact that ██████████ was alleged to not contact her directly and that the post could not be located, Sgt. Brennan contacted the Bergen County Prosecutor's Office and spoke with on-call Assistant Prosecutor Martha Grant, in regards to the case.

As the case was being discussed with AP Grant, ██████████ stated that she did not want to wait anymore even though she was advised that we were getting legal advise for her case. She further stated that it was getting late and she had to work early in the morning. She requested that her cell phone, where the picture was being displayed, be returned and left police headquarters. ██████████ has a court date scheduled regarding her TRO on 2/26/19 at 1:30P in courtroom 317 before the Honorable Avis Bishop-Thompson of Bergen County Superior Court.

A New Jersey Victim Notification Form was completed for ██████████. A copy of the form was later faxed to the Bergen County Domestic Violence Intake Unit. The form was scanned and can be found attached to this report.

The picture of the Facebook post, provided by ██████████ and a copy of the TRO, were attached to this report.

The incident was recorded in the Mobile Video Recorder (MVR) in motor patrol vehicle #16.

Officer of Record:

Date:

PO Antherson Ramirez 350

02/21/19



Teaneck Police Department

900 Teaneck Rd, Teaneck, NJ 07666

Phone: 201-837-2600 Fax: 201-837-1880 Mun. Code: 0260

Incident Report



Incident Details:

| | | | | | | | | | |
|-------------|---------------|---------------|---------------|---------------|-----------------------------------|---------------|---------------|-----|-----------|
| Case Number | Time Reported | Date Reported | Time Occurred | Date Occurred | Occurrence Between Date / Time of | Time Occurred | Date Occurred | 911 | Completed |
| 19-020389 | 17:37 | 04/14/19 | 17:37 | 04/14/19 | | | | X | X |

Incident Type:

Welfare Check
Medical Emergency

Incident Location:

Street # Street Name Intersection / Cross Street of:
 1354 Teaneck Road Teaneck Road / Garden St
 Business / Common Location Name

Contact Information: Victim Suspect Complainant Witness Driver Arrest Passenger Missing Involved Other

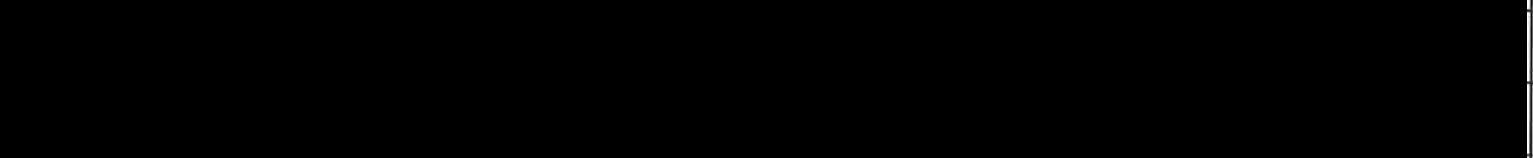

| Code | Contact Name #1 | MI | Suffix | Age | Sex | Race | DOB | SSN |
|---------|-----------------|----|--------|-----|-----|------------|-----|------------|
| | | | | | | | | |
| Address | | | | | | Home Phone | | Cell Phone |
| Code | Contact Name #3 | MI | Suffix | Age | Sex | Race | DOB | SSN |
| | | | | | | | | |
| Address | | | | | | Home Phone | | Cell Phone |
| Code | Contact Name #4 | MI | Suffix | Age | Sex | Race | DOB | SSN |
| | | | | | | | | |
| Address | | | | | | Home Phone | | Cell Phone |

Property Information:

| Value of Stolen Property | Currency | Jewelry | Furs | Clothing | Auto | Misc. | Total |
|------------------------------------|----------|---------|------|----------|------|-------|-------|
| | | | | | | | |
| Value of Stolen Property Recovered | | | | | | | |

Automobile Information:

| 1 | Vehicle Code | Year | Make | Body Type | Model | Color | Registration | State | VIN |
|---|--------------|------|------|-----------|-------|-------|--------------|-------|-----|
| 2 | | | | | | | | | |
| 3 | | | | | | | | | |
| 4 | | | | | | | | | |

Narrative:

On Sunday, April 14, 2019 at 5:37 p.m., Officer Batista and I responded to the area of 1356 Teaneck Road, on a welfare check of a person that appeared to be intoxicated.

Upon my arrival, I observed a person later identified as [REDACTED] sitting, slouched over on the bus stop bench. I observed an open 3/4 consumed 750 ml bottle of Patron Tequila next to him and a bottle of seltzer water spilled over next to him. I observed a wet spot on his pants in the area of his crotch appearing that he may have soiled himself.

Officer of Record: Date: Other Reports Filed: Reviewed By:

| | | | |
|------------------------|----------|---|----------|
| PO Daniel Antinori 351 | 04/14/19 | MVA Arrest DV DWI DWIQ Tow SD CI TRO | jgarland |
| | | SHA Prop. Video UOF Prst Supp Juv Bias Pris | |



Teaneck Police Department

900 Teaneck Rd, Teaneck, NJ 07666

Phone: 201-837-2600 Fax: 201-837-1880 Mun. Code: 0260

Incident Report



Narrative Continued (Page 2)

Case Number

19-020389

I woke up my [REDACTED] who appeared to be disoriented and lethargic. When standing [REDACTED] was swaying and needed support to walk. [REDACTED] stated that he lived at 17 West Englewood Ave but was unsure if anyone was home.

Due to [REDACTED] being intoxicated and him not being sure if anyone was home, I requested an ambulance to transport him to HNMC in compliance with NJ ATRA laws. I poured out then discarded the open bottle of tequila and seltzer water.

TVAC 71 arrived on scene and I searched [REDACTED] for any weapons. [REDACTED] was then placed on a stretcher and transported to HNMC where he was turned over to emergency room medical staff for further treatment.

Officer of Record:

Date:

PO Daniel Antinori 351

04/14/19



Teaneck Police Department

900 Teaneck Rd, Teaneck, NJ 07666

Phone: 201-837-2600 Fax: 201-837-1880 Mun. Code: 0260

Incident Report



Incident Details:

| | | | | | | | | | |
|-------------|---------------|---------------|---------------|---------------|-----------------------------------|---------------|---------------|-----|-----------|
| Case Number | Time Reported | Date Reported | Time Occurred | Date Occurred | Occurrence Between Date / Time of | Time Occurred | Date Occurred | 911 | Completed |
| 19-034813 | 15:47 | 06/27/19 | 12:00 | 06/27/19 | | 12:00 | 06/27/19 | | X |

Incident Type:

Harassment 2C:33-4

Incident Location:

Street # Street Name Intersection / Cross Street of:
 1354 Teaneck Road
 Business / Common Location Name

Contact Information: Victim Suspect Complainant Witness Driver Arrest Passenger Missing Involved Other

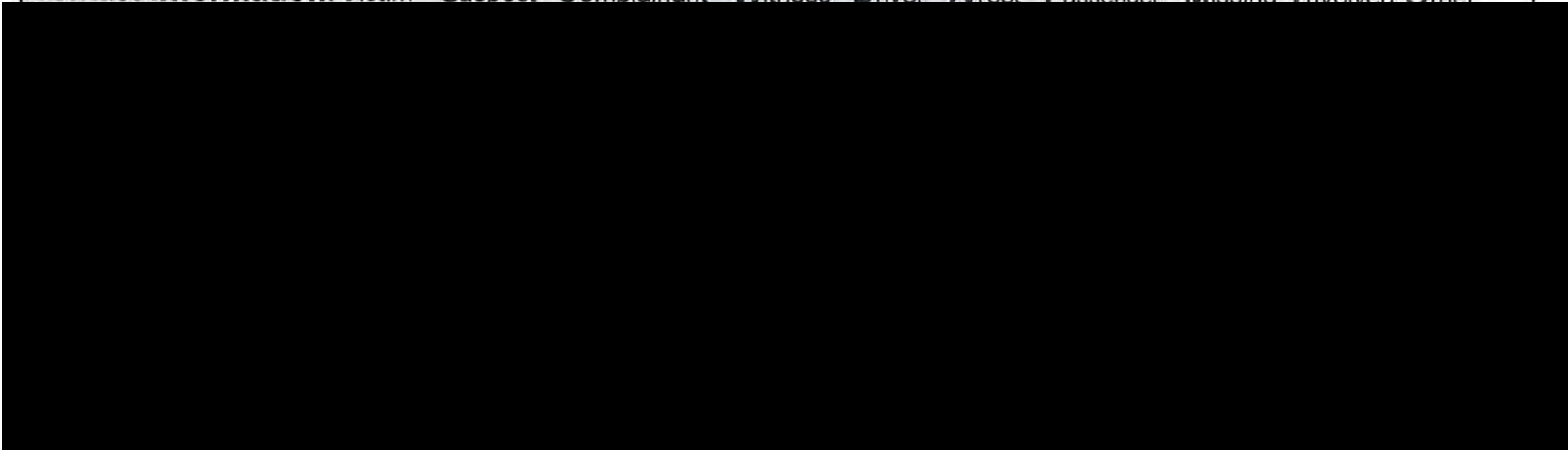

| | | | | | |
|--------------|-----|-----|------------|------------|-----|
| Contact Name | Age | Sex | Race | DOB | SSN |
| Address | | | Home Phone | Cell Phone | |

Property Information:

| | | | | | | | |
|------------------------------------|----------|---------|------|----------|------|-------|-------|
| Value of Stolen Property | Currency | Jewelry | Furs | Clothing | Auto | Misc. | Total |
| Value of Stolen Property Recovered | | | | | | | |

Automobile Information:

| | Vehicle Code | Year | Make | Body Type | Model | Color | Registration | State | VIN |
|---|--------------|------|------|-----------|-------|-------|--------------|-------|-----|
| 1 | | | | | | | | | |
| 2 | | | | | | | | | |
| 3 | | | | | | | | | |
| 4 | | | | | | | | | |

Narrative:

On Thursday, June 27, 2019, at approximately 2:30 PM, [REDACTED] the owner of Reggae Kitchen, 1354 Teaneck Road walked into headquarters to speak with me. [REDACTED] wanted to report that [REDACTED] had walked into her business and spoke with an employee, [REDACTED]. According to [REDACTED] walked into Reggae Kitchen was saying threatening things about [REDACTED].

[REDACTED] wished to document this incident as there has been an ongoing problem between her and Ms. [REDACTED] advised me that she was going to contact her attorney, [REDACTED] and speak with him about his incident.

| | | | | | | | | | | | | |
|---------------------------|--------------|-----------------------------|--------|-------|-----|------|--------|-----|------|------|--|---------------------|
| Officer of Record: | Date: | Other Reports Filed: | | | | | | | | | | Reviewed By: |
| Det. Thomas Melvin 219 | 06/27/19 | MVA | Arrest | DV | DWI | DWIQ | Tow | SD | CI | TRO | | zlopez |
| | | SHA | Prop. | Video | UOF | Prst | Supp 1 | Juv | Bias | Pris | | |



Teaneck Police Department

900 Teaneck Rd, Teaneck, NJ 07666

Phone: 201-837-2600 Fax: 201-837-1880 Mun. Code: 0260

Incident Report



Narrative Continued (Page 2)

Case Number

19-034813

I was not able to speak with [REDACTED] at the time of this report.

Detective Thomas P. Melvin #219

Officer of Record:

Date:

Det. Thomas Melvin 219

06/27/19

| 96 05 | Page 1 of 2 <input type="checkbox"/> Fatal New Jersey Police Crash Investigation Report <input checked="" type="checkbox"/> Reportable <input type="checkbox"/> Non-Reportable <input type="checkbox"/> Change Report | | | | | | | | | | 118a 25 | | | | | | | | | | | | | | | | | | | | | | | | | | | | | | | | | | | | | | | | | | | | | | | | | | | | | | | | | | | | | | | | | | | | | | | | | | | | | |
|--|--|-----|--|---|--|---|-------------------------------------|------------------------------|--|--|-------------------------------|--------------|-------------|---|----|----|----|----|----|----|----|----|----|----|----|----|---|---|---|----|----|----|----|---|----|----|----|----|----|----|-----|-----------------------------|---|-----|-----|-----|-----|-----|-----|-----|-----|-----|-----|-----|-----|-----|-----|---|-----|-----|-----|-----|-----|-----|-----|-----|-----|-----|-----|-----|-----|-----|---|-----|-----|-----|-----|-----|-----|-----|-----|-----|-----|-----|-----|-----|-----|-----------|
| 97 01 | 1. Case Number 19-039391 | | | 10. Crash Occurred On: Teaneck Road | | | | 11. Speed Limit 30 | | 12. Route No. Suffix | | 13. Milepost | | 118b --- | | | | | | | | | | | | | | | | | | | | | | | | | | | | | | | | | | | | | | | | | | | | | | | | | | | | | | | | | | | | | | | | | | | | | | | | | | |
| 98 01 | 2. Police Dept. of Teaneck Code 01 | | | Road Name W Englewood Ave | | | | 18. Speed Limit 25 | | 19. To: 17. Cross Road Name/Route No. | | 119a 00 | | | | | | | | | | | | | | | | | | | | | | | | | | | | | | | | | | | | | | | | | | | | | | | | | | | | | | | | | | | | | | | | | | | | | | | | | | | | |
| 99 05 | 3. Station/Precinct 100 | | | <input type="checkbox"/> At Intersection with <input checked="" type="checkbox"/> Feet <input type="checkbox"/> Miles | | <input type="checkbox"/> N <input type="checkbox"/> E <input checked="" type="checkbox"/> S <input type="checkbox"/> W | | 19. From: 14 | | <input type="checkbox"/> NB <input type="checkbox"/> EB <input type="checkbox"/> SB <input type="checkbox"/> WB | | 119b --- | | | | | | | | | | | | | | | | | | | | | | | | | | | | | | | | | | | | | | | | | | | | | | | | | | | | | | | | | | | | | | | | | | | | | | | | | | | | |
| 100a 01 | 4. Date of Crash mm dd yy 07 21 19 | | 5. Day of Week (S) M Tu W Th F Sa | | 6. Time (use 2400 hrs.) 1517 | | 7. Municipality Code 0260 | | 8. Total Killed 00 | | 9. Total Injured 00 | | 120a --- | | | | | | | | | | | | | | | | | | | | | | | | | | | | | | | | | | | | | | | | | | | | | | | | | | | | | | | | | | | | | | | | | | | | | | | | | | | |
| 100b 04 | 23. Veh. # 1 | | 24. Policy No. A02-232-082741-01 8 0 | | | 26. NJ Ins. Code 182 | | 63. Veh. # 2 | | 54. Policy No. UNKNOWN | | | 120b --- | | | | | | | | | | | | | | | | | | | | | | | | | | | | | | | | | | | | | | | | | | | | | | | | | | | | | | | | | | | | | | | | | | | | | | | | | | | |
| 101 01 | <input checked="" type="checkbox"/> Parked <input type="checkbox"/> Ped <input type="checkbox"/> Pedalcyclist <input type="checkbox"/> Resp. to Emergency <input type="checkbox"/> Hit & Run | | | | <input type="checkbox"/> Parked <input type="checkbox"/> Ped <input type="checkbox"/> Pedalcyclist <input type="checkbox"/> Resp. to Emergency <input checked="" type="checkbox"/> Hit & Run | | | | 28. Driver's First Name Initial Last Name | | | | 121a 00 | | | | | | | | | | | | | | | | | | | | | | | | | | | | | | | | | | | | | | | | | | | | | | | | | | | | | | | | | | | | | | | | | | | | | | | | | | | |
| 102 01 | 27. Number & Street | | | | 29. Sex UNKNOWN | | | | 57. Number & Street UNKNOWN | | | | 121b --- | | | | | | | | | | | | | | | | | | | | | | | | | | | | | | | | | | | | | | | | | | | | | | | | | | | | | | | | | | | | | | | | | | | | | | | | | | | |
| 103 01 | 28. City State Zip | | | | 58. City State Zip | | | | 60. Eyes DL Class Restrictions Endorsements 31. State | | | | 122 10 | | | | | | | | | | | | | | | | | | | | | | | | | | | | | | | | | | | | | | | | | | | | | | | | | | | | | | | | | | | | | | | | | | | | | | | | | | | |
| 104 02 | 30. Eyes DL Class Restrictions Endorsements 31. State | | | | 60. Eyes DL Class Restrictions Endorsements 61. State | | | | 32. Driver's License Number | | | | 123 00 | | | | | | | | | | | | | | | | | | | | | | | | | | | | | | | | | | | | | | | | | | | | | | | | | | | | | | | | | | | | | | | | | | | | | | | | | | | |
| 105 06 | 33. DOB mm dd yy | | | | 34. Expires mm yy | | | | 62. Driver's License Number | | | | 124 11 | | | | | | | | | | | | | | | | | | | | | | | | | | | | | | | | | | | | | | | | | | | | | | | | | | | | | | | | | | | | | | | | | | | | | | | | | | | |
| 106 --- | 35. Owner's First Name Initial Last Name <input type="checkbox"/> Same as Driver Rubena B Reynolds | | | | 65. Owner's First Name Initial Last Name <input type="checkbox"/> Same as Driver UNKNOWN | | | | 36. Number & Street 1568 Crescent Ave | | | | 125 11 | | | | | | | | | | | | | | | | | | | | | | | | | | | | | | | | | | | | | | | | | | | | | | | | | | | | | | | | | | | | | | | | | | | | | | | | | | | |
| 107 --- | 37. City State Zip Teaneck, NJ 07666-6102 | | | | 67. City State Zip | | | | 38. Make 39. Model 40. Color 41. Year 42. Plate No. 43. State LEX RX3 RD 10 VDU32H NJ | | | | 126a 26 | | | | | | | | | | | | | | | | | | | | | | | | | | | | | | | | | | | | | | | | | | | | | | | | | | | | | | | | | | | | | | | | | | | | | | | | | | | |
| 108 01 | 44. VIN 2T2BK1BA4AC028935 | | | | 45. Expires 10/19 | | | | 68. Make 69. Model 70. Color 71. Year 72. Plate No. 73. State | | | | 126b --- | | | | | | | | | | | | | | | | | | | | | | | | | | | | | | | | | | | | | | | | | | | | | | | | | | | | | | | | | | | | | | | | | | | | | | | | | | | |
| 109 00 | 46. Vehicle Removed to: | | | | 76. Vehicle Removed to: | | | | 47. Authority <input type="checkbox"/> Owner <input checked="" type="checkbox"/> Driver <input type="checkbox"/> Police | | | | 126c --- | | | | | | | | | | | | | | | | | | | | | | | | | | | | | | | | | | | | | | | | | | | | | | | | | | | | | | | | | | | | | | | | | | | | | | | | | | | |
| 110 00 | <input checked="" type="checkbox"/> Driven <input type="checkbox"/> Towed Disabled <input type="checkbox"/> Towed Disabled & Impounded <input type="checkbox"/> Left at Scene <input type="checkbox"/> Towed Impounded | | | | <input checked="" type="checkbox"/> Driven <input type="checkbox"/> Towed Disabled <input type="checkbox"/> Towed Disabled & Impounded <input type="checkbox"/> Left at Scene <input type="checkbox"/> Towed Impounded | | | | 48. Alcohol Drug Test Given: <input checked="" type="checkbox"/> No <input type="checkbox"/> Yes <input type="checkbox"/> Refused Type: <input type="checkbox"/> Breath <input type="checkbox"/> Blood <input type="checkbox"/> Urine Results: 0 % <input type="checkbox"/> Pending | | | | 126e 26 | | | | | | | | | | | | | | | | | | | | | | | | | | | | | | | | | | | | | | | | | | | | | | | | | | | | | | | | | | | | | | | | | | | | | | | | | | | |
| 111 00 | 49. Hazardous Material <input checked="" type="checkbox"/> None <input type="checkbox"/> On Board <input type="checkbox"/> Spill | | | | 78. Alcohol Drug Test Given: <input checked="" type="checkbox"/> No <input type="checkbox"/> Yes <input type="checkbox"/> Refused Type: <input type="checkbox"/> Breath <input type="checkbox"/> Blood <input type="checkbox"/> Urine Results: 0 % <input type="checkbox"/> Pending | | | | 79. Hazardous Material <input type="checkbox"/> None <input type="checkbox"/> On Board <input type="checkbox"/> Spill | | | | 127a 28 | | | | | | | | | | | | | | | | | | | | | | | | | | | | | | | | | | | | | | | | | | | | | | | | | | | | | | | | | | | | | | | | | | | | | | | | | | | |
| 112 --- | 50. Carrier No. <input type="checkbox"/> USDOT <input checked="" type="checkbox"/> None | | | | 51. GVWR / GCWR (trucks & buses only) <input type="checkbox"/> ≤ 10,000 lbs. <input type="checkbox"/> 10,001 - 26,000 lbs. <input type="checkbox"/> ≥ 26,001 lbs. | | | | 80. Carrier No. <input type="checkbox"/> USDOT <input checked="" type="checkbox"/> None | | | | 127b --- | | | | | | | | | | | | | | | | | | | | | | | | | | | | | | | | | | | | | | | | | | | | | | | | | | | | | | | | | | | | | | | | | | | | | | | | | | | |
| 113 --- | 52. Motor Carrier or Government Entity | | | | 81. GVWR / GCWR (trucks & buses only) <input type="checkbox"/> ≤ 10,000 lbs. <input type="checkbox"/> 10,001 - 26,000 lbs. <input type="checkbox"/> ≥ 26,001 lbs. | | | | 82. Motor Carrier or Government Entity | | | | 127c --- | | | | | | | | | | | | | | | | | | | | | | | | | | | | | | | | | | | | | | | | | | | | | | | | | | | | | | | | | | | | | | | | | | | | | | | | | | | |
| 114 --- | Number & Street | | | | 83. Motor Carrier or Government Entity | | | | Number & Street | | | | 127d --- | | | | | | | | | | | | | | | | | | | | | | | | | | | | | | | | | | | | | | | | | | | | | | | | | | | | | | | | | | | | | | | | | | | | | | | | | | | |
| 115 --- | City State Zip | | | | 84. Motor Carrier or Government Entity | | | | City State Zip | | | | 127e 28 | | | | | | | | | | | | | | | | | | | | | | | | | | | | | | | | | | | | | | | | | | | | | | | | | | | | | | | | | | | | | | | | | | | | | | | | | | | |
| 116 03 | 135. Damage to Other Property <input type="checkbox"/> Yes (if Yes, describe) <input checked="" type="checkbox"/> No | | | | | | | | | | | | 128 26 | | | | | | | | | | | | | | | | | | | | | | | | | | | | | | | | | | | | | | | | | | | | | | | | | | | | | | | | | | | | | | | | | | | | | | | | | | | |
| 117 00 | Oper. 136. Charge | | | 137. Summons No. | | | Oper. 138. Charge | | | 139. Summons No. | | | 128a 10 | | | | | | | | | | | | | | | | | | | | | | | | | | | | | | | | | | | | | | | | | | | | | | | | | | | | | | | | | | | | | | | | | | | | | | | | | | | |
| 118 00 | Oper. 140. Charge | | | 141. Summons No. | | | Oper. 142. Charge | | | 143. Summons No. | | | 129 10 | | | | | | | | | | | | | | | | | | | | | | | | | | | | | | | | | | | | | | | | | | | | | | | | | | | | | | | | | | | | | | | | | | | | | | | | | | | |
| <table border="1"> <thead> <tr> <th></th> <th>83</th> <th>84</th> <th>85</th> <th>86</th> <th>87</th> <th>88</th> <th>89</th> <th>90</th> <th>91</th> <th>92</th> <th>93</th> <th>94</th> <th>95</th> <th>Names & Addresses of Occupants If Deceased, Date & Time of Death</th> </tr> </thead> <tbody> <tr> <td>A</td> <td>2</td> <td>01</td> <td>01</td> <td>00</td> <td>00</td> <td>U</td> <td>00</td> <td>00</td> <td>00</td> <td>00</td> <td>00</td> <td>00</td> <td>---</td> <td>UNKNOWN DRIVER OF VEHICLE 2</td> </tr> <tr> <td>B</td> <td>---</td> <td>---</td> <td>---</td> <td>---</td> <td>---</td> <td>---</td> <td>---</td> <td>---</td> <td>---</td> <td>---</td> <td>---</td> <td>---</td> <td>---</td> <td>---</td> </tr> <tr> <td>C</td> <td>---</td> <td>---</td> <td>---</td> <td>---</td> <td>---</td> <td>---</td> <td>---</td> <td>---</td> <td>---</td> <td>---</td> <td>---</td> <td>---</td> <td>---</td> <td>---</td> </tr> <tr> <td>D</td> <td>---</td> <td>---</td> <td>---</td> <td>---</td> <td>---</td> <td>---</td> <td>---</td> <td>---</td> <td>---</td> <td>---</td> <td>---</td> <td>---</td> <td>---</td> <td>---</td> </tr> </tbody> </table> | | | | | | | | | | | | | | 83 | 84 | 85 | 86 | 87 | 88 | 89 | 90 | 91 | 92 | 93 | 94 | 95 | Names & Addresses of Occupants If Deceased, Date & Time of Death | A | 2 | 01 | 01 | 00 | 00 | U | 00 | 00 | 00 | 00 | 00 | 00 | --- | UNKNOWN DRIVER OF VEHICLE 2 | B | --- | --- | --- | --- | --- | --- | --- | --- | --- | --- | --- | --- | --- | --- | C | --- | --- | --- | --- | --- | --- | --- | --- | --- | --- | --- | --- | --- | --- | D | --- | --- | --- | --- | --- | --- | --- | --- | --- | --- | --- | --- | --- | --- | 130 10 |
| | 83 | 84 | 85 | 86 | 87 | 88 | 89 | 90 | 91 | 92 | 93 | 94 | 95 | Names & Addresses of Occupants If Deceased, Date & Time of Death | | | | | | | | | | | | | | | | | | | | | | | | | | | | | | | | | | | | | | | | | | | | | | | | | | | | | | | | | | | | | | | | | | | | | | | | | | |
| A | 2 | 01 | 01 | 00 | 00 | U | 00 | 00 | 00 | 00 | 00 | 00 | --- | UNKNOWN DRIVER OF VEHICLE 2 | | | | | | | | | | | | | | | | | | | | | | | | | | | | | | | | | | | | | | | | | | | | | | | | | | | | | | | | | | | | | | | | | | | | | | | | | | |
| B | --- | --- | --- | --- | --- | --- | --- | --- | --- | --- | --- | --- | --- | --- | | | | | | | | | | | | | | | | | | | | | | | | | | | | | | | | | | | | | | | | | | | | | | | | | | | | | | | | | | | | | | | | | | | | | | | | | | |
| C | --- | --- | --- | --- | --- | --- | --- | --- | --- | --- | --- | --- | --- | --- | | | | | | | | | | | | | | | | | | | | | | | | | | | | | | | | | | | | | | | | | | | | | | | | | | | | | | | | | | | | | | | | | | | | | | | | | | |
| D | --- | --- | --- | --- | --- | --- | --- | --- | --- | --- | --- | --- | --- | --- | | | | | | | | | | | | | | | | | | | | | | | | | | | | | | | | | | | | | | | | | | | | | | | | | | | | | | | | | | | | | | | | | | | | | | | | | | |



Teaneck Police Department

900 Teaneck Rd, Teaneck, NJ 07666

Phone: 201-837-2600 Fax: 201-837-1880 Mun. Code: 0260

Incident Report



Incident Details:

| | | | | | | | | | |
|-------------|---------------|---------------|---------------|---------------|-----------------------------------|---------------|---------------|-----|-----------|
| Case Number | Time Reported | Date Reported | Time Occurred | Date Occurred | Occurrence Between Date / Time of | Time Occurred | Date Occurred | 911 | Completed |
| 20-022057 | 13:07 | 05/03/20 | 12:00 | 05/01/20 | | 16:00 | | | X |

Incident Type:

Lost Property

Incident Location:

Street # Street Name Intersection / Cross Street of:
 1354 Teaneck Road
 Business / Common Location Name

Contact Information: Victim Suspect Complainant Witness Driver Arrest Recipient Missing Injured Other

| | | | | | | | | |
|---------|-----------------|----|--------|-----|-----|------------|-----|------------|
| Code | Contact Name #2 | MI | Suffix | Age | Sex | Race | DOB | SSN |
| Address | | | | | | Home Phone | | Cell Phone |
| Code | Contact Name #3 | MI | Suffix | Age | Sex | Race | DOB | SSN |
| Address | | | | | | Home Phone | | Cell Phone |
| Code | Contact Name #4 | MI | Suffix | Age | Sex | Race | DOB | SSN |
| Address | | | | | | Home Phone | | Cell Phone |

Property Information:

| | | | | | | | |
|------------------------------------|----------|---------|------|----------|------|-------|-------|
| Value of Stolen Property | Currency | Jewelry | Furs | Clothing | Auto | Misc. | Total |
| Value of Stolen Property Recovered | | | | | | | |

Automobile Information:

| 1 | Vehicle Code | Year | Make | Body Type | Model | Color | Registration | State | VIN |
|---|--------------|------|------|-----------|-------|-------|--------------|-------|-----|
| 2 | | | | | | | | | |
| 3 | | | | | | | | | |
| 4 | | | | | | | | | |

Narrative:

On Sunday, May 3, 2020 [REDACTED] submitted a police report via e-mail, where she reported that she lost her blue snake skin wallet containing identification cards, four hundred to six hundred dollars in cash, social security card, health cards, service dog identification disability, driver license, a Chase Bank debit card, two Visa Pre-Paid card, Chime card and a Victim Notification Form from Teaneck Police Department.

I spoke to [REDACTED] who advised me that she contacted her financial institutions and advised them that she lost her wallet.

Officer of Record: Date: Other Reports Filed: Reviewed By:

| | | | |
|------------------------|----------|---|----------|
| PO Victoria Suarez 320 | 05/03/20 | MVA Arrest DV DWI DWIQ Tow SD CI TRO | pforrest |
| | | SHA Prop. Video UOF Prst Supp Juv Bias Pris | |



Teaneck Police Department

900 Teaneck Rd, Teaneck, NJ 07666

Phone: 201-837-2600 Fax: 201-837-1880 Mun. Code: 0260

Incident Report



Incident Details:

| | | | | | | | | | |
|-------------|---------------|---------------|---------------|---------------|-----------------------------------|---------------|---------------|-----|-----------|
| Case Number | Time Reported | Date Reported | Time Occurred | Date Occurred | Occurrence Between Date / Time of | Time Occurred | Date Occurred | 911 | Completed |
| 20-032359 | 06:00 | 07/04/20 | 06:00 | 07/04/20 | | | | | X |

Incident Type:

Criminal Mischief 2C:17-3
Observ Rpt -General

Incident Location:

Street # Street Name Intersection / Cross Street of:
 1354 Teaneck Road Teaneck Road / Garden St
 Business / Common Location Name

Contact Information: Victim Suspect Complainant Witness Driver Arrest Passenger Missing Involved Other

| Code | Contact Name #1 | MI | Suffix | Age | Sex | Race | DOB | SSN |
|---------|-----------------|----|--------|-----|-----|------------|-----|------------|
| | | | | | | | | |
| Address | | | | | | Home Phone | | Cell Phone |
| | | | | | | | | |
| Address | | | | | | Home Phone | | Cell Phone |
| | | | | | | | | |
| Address | | | | | | Home Phone | | Cell Phone |
| | | | | | | | | |
| Address | | | | | | Home Phone | | Cell Phone |

Property Information:

| | | | | | | | |
|------------------------------------|----------|---------|------|----------|------|-------|-------|
| Value of Stolen Property | Currency | Jewelry | Furs | Clothing | Auto | Misc. | Total |
| Value of Stolen Property Recovered | | | | | | | |

Automobile Information:

| 1 | Vehicle Code | Year | Make | Body Type | Model | Color | Registration | State | VIN |
|---|--------------|------|------|-----------|-------|-------|--------------|-------|-----|
| 2 | | | | | | | | | |
| 3 | | | | | | | | | |
| 4 | | | | | | | | | |

Narrative:

On Saturday, July 4, 2020, I was assigned to Motor Patrol, patrolling Old Post North in SUV #9. At approximately 6:04 A.M. I was conducting a business check in the area of 1354 Teaneck Road when I observed a municipal trash can and a El Especialito newspaper dispenser that had been knock over on the sidewalk. The trash can appeared to have been displaced approximately 10 feet south from its original position. Debris that were contained in the trash can spilled on the sidewalk.

The municipal trash can and magazine dispenser did not have significant damage indicating that they were not struck by a vehicle. They appeared to have been displaced by an unknown actor. I also observed other trash cans and cardboard boxes within 50 yards of 1354 Teaneck Road,

| | | | | | | | | | | | | |
|---------------------------|--------------|-----------------------------|--------|-------|-----|------|------|-----|------|------|--|---------------------|
| Officer of Record: | Date: | Other Reports Filed: | | | | | | | | | | Reviewed By: |
| PO Brandon Graham | 354 07/04/20 | MVA | Arrest | DV | DWI | DWIQ | Tow | SD | CI | TRO | | |
| | | SHA | Prop. | Video | UOF | Prst | Supp | Juv | Bias | Pris | | gwright |



Teaneck Police Department

900 Teaneck Rd, Teaneck, NJ 07666

Phone: 201-837-2600 Fax: 201-837-1880 Mun. Code: 0260

Incident Report



Narrative Continued (Page 2)

Case Number

20-032359

however they did not appear to be disturbed.

Sgt. D. Dalessio #314 arrived on scene to assist. The municipal trash can and El Especialito newspaper dispenser were placed upright on the sidewalk and the debris were organized into a pile.

The Teaneck Department of Public Works was notified of this incident with a problem report so they could collect the trash.

Officer of Record:

Date:

PO Brandon Graham 354

07/04/20



Teaneck Police Department

900 Teaneck Rd, Teaneck, NJ 07666

Phone: 201-837-2600 Fax: 201-837-1880 Mun. Code: 0260

Incident Report



| Incident Details: | | | | | | | | | |
|-------------------|---------------|---------------|---------------|---------------|-----------------------------------|---------------|---------------|-----|-----------|
| Case Number | Time Reported | Date Reported | Time Occurred | Date Occurred | Occurrence Between Date / Time of | Time Occurred | Date Occurred | 911 | Completed |
| 21-011972 | 14:31 | 03/08/21 | | | | | | X | X |

| Incident Type: | Incident Location: |
|-----------------------------|---|
| Commitment Welfare Check | Street # Street Name 1354 Teaneck Road Intersection / Cross Street of: Teaneck Road / Garden St Business / Common Location Name |

Contact Information: Victim Suspect Complainant Witness Driver Arrest Passenger Missing Involved Other

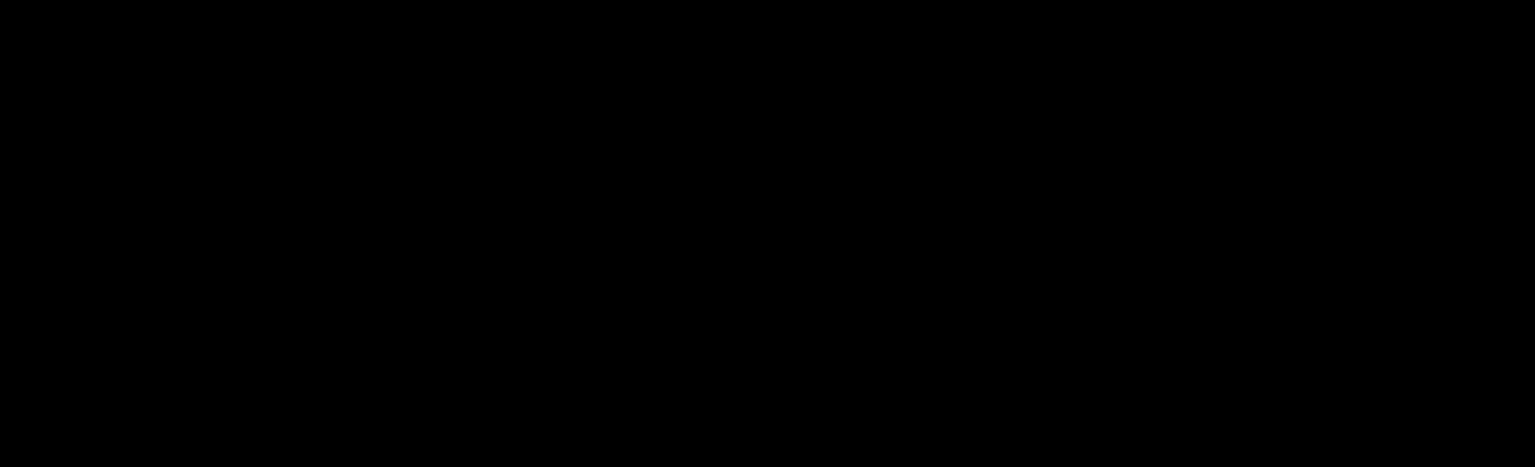

| | | |
|---------|------------|------------|
| Address | Home Phone | Cell Phone |
|---------|------------|------------|

| Property Information: | | | | | | | |
|------------------------------------|----------|---------|------|----------|------|-------|-------|
| Value of Stolen Property | Currency | Jewelry | Furs | Clothing | Auto | Misc. | Total |
| Value of Stolen Property Recovered | | | | | | | |

| Automobile Information: | | | | | | | | | |
|-------------------------|--------------|------|------|-----------|-------|-------|--------------|-------|-----|
| 1 | Vehicle Code | Year | Make | Body Type | Model | Color | Registration | State | VIN |
| 2 | | | | | | | | | |
| 3 | | | | | | | | | |
| 4 | | | | | | | | | |

Narrative:
 On Monday, March 9, 2021 at approximately 2:31 PM, Sergeant D. Dalessio #314 and I responded to the area of 1354 Teaneck Road on a report of a female caller at the bus stop having a mental breakdown. I responded in motor patrol vehicle #16 with the in car camera activated.
 Once in the area a known party [REDACTED] approached my vehicle in the parking lot of 1400 Teaneck Road [REDACTED] reported that she had recently had a verbal argument with her mother and left the residence to cool down. While speaking to her about that she stated that she wanted an investigation done on her mother, brother and ex-boyfriend as she believed they were sex trafficking her.

| Officer of Record: | Date: | Other Reports Filed: | Reviewed By: |
|----------------------|----------|---|--------------|
| PO Dmitri Rueger 346 | 03/08/21 | MVA Arrest DV DWI DWIQ Tow SD CI TRO SHA Prop. Video UOF Prst Supp Juv Bias Pris | ddalessio |



Teaneck Police Department

900 Teaneck Rd, Teaneck, NJ 07666

Phone: 201-837-2600 Fax: 201-837-1880 Mun. Code: 0260

Incident Report



Narrative Continued (Page 2)

Case Number
21-011972

When asking her how they were doing this she stated that the things they would say to her made her feel this way. They will not allow her to be independent and want "a man to take care of her". She would mention very vague statements about sexual harassment, rape and sex trafficking. When we inquired more about these incidents she did not have information that would lead to believe there was any criminal activity happening to her at this time. Also while on scene she stated that she believed someone was messing with her in the "spiritual and physical realm" and that she believes her mom has performed voodoo on her.

While on scene [REDACTED] was asked if she would like to be voluntarily transported to the hospital to be medically evaluated due to her claims of possible sex crimes committed against her which she declined. [REDACTED] has been committed to the hospital by this department on numerous occasions for psychiatric evaluations. She stated that she currently has a therapist through Care Plus named Sam that she speaks to occasionally. She has been prescribed medications but was not taking them at this time.

Due to the conversation I was having with her and her calling 9-1-1 for mental health concerns, I contacted 262-HELP to have a screener respond to our location. They stated that we would need to bring [REDACTED] to our police department or her residence in order to conduct the screening. [REDACTED] did not want to go back to her residence due to the verbal argument with her mother. Before placing her in the rear of my motor patrol vehicle I asked if she had any weapons on her and she stated she had a folding knife in her back pack. I placed the knife and her back pack in the front of my motor patrol vehicle during the transport. I placed her in the rear of my motor patrol vehicle and transported her to police headquarters while Sergeant Dalessio followed.

At headquarters [REDACTED] was escorted to the lobby where we waited for the screener to arrive. The screener [REDACTED] arrived a short while after and spoke with [REDACTED]. While at headquarters, [REDACTED] mother [REDACTED] arrived in the parking lot. Sergeant Dalessio and Ms. [REDACTED] spoke with [REDACTED] in the parking lot while I remained with [REDACTED] in the lobby. When Ms. [REDACTED] was informed that she would be involuntarily transported to Bergen New Bridge Medical Center (BNBMC), she became extremely furious. She was yelling loudly in the lobby stating that she did not want to go to the hospital, asking why she was going and stating that she is sexually harassed in the hospital as well and did not trust the staff. [REDACTED] behavior became so irate that available units were called to respond to headquarters because of her behavior.

Once we were able to slightly calm [REDACTED] down, she was escorted to motor patrol vehicle #9 where Officer R. Vallejos #362 and Officer J. Noguerras #284 transported [REDACTED] to BNBMC as I followed. At BNBMC [REDACTED] was still furious and being difficult with hospital staff. We were eventually able to transfer her over to hospital security and staff.

Officer of Record:

Date:

PO Dmitri Rueger 346

03/08/21



Teaneck Police Department

900 Teaneck Rd, Teaneck, NJ 07666

Phone: 201-837-2600 Fax: 201-837-1880 Mun. Code: 0260

Incident Report



Narrative Continued (Page 3)

Case Number
21-011972

Attached to this report are the following documents:

- A Division of Mental Health Services, Screening Outreach Request For Police Transport And Supervision Form
- A BNBMC Security Department Acceptance Form

The black and silver foldable knife found in [REDACTED] backpack was secured for safekeeping. The knife was logged into the BEAST evidence system. It was placed in a brown paper bag and stored in Temporary Evidence Locker #114.

BWC.

| | |
|---------------------------|--------------|
| Officer of Record: | Date: |
| PO Dmitri Rueger 346 | 03/08/21 |



Teaneck Police Department

900 Teaneck Rd, Teaneck, NJ 07666

Phone: 201-837-2600 Fax: 201-837-1880 Mun. Code: 0260

Incident Report



Incident Details:

| | | | | | | | | | |
|-------------|---------------|---------------|---------------|---------------|-----------------------------------|---------------|---------------|-----|-----------|
| Case Number | Time Reported | Date Reported | Time Occurred | Date Occurred | Occurrence Between Date / Time of | Time Occurred | Date Occurred | 911 | Completed |
| 21-042192 | 17:48 | 08/05/21 | 17:48 | 08/05/21 | | | | X | X |

Incident Type:

Medical Emergency

Incident Location:

Street # Street Name Intersection / Cross Street of:
 1354 Teaneck Road Teaneck Road / Garden St
 Business / Common Location Name

Contact Information: Victim Suspect Complainant Witness Driver Arrest Passenger Missing Involved Other

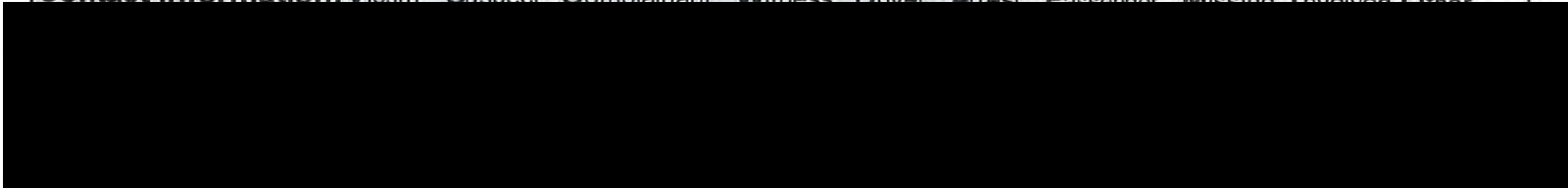

| | | | | | | | | | |
|---------|-----------------|----|--------|-----|-----|------------|-----|------------|--|
| Address | | | | | | Home Phone | | Cell Phone | |
| Code | Contact Name #3 | MI | Suffix | Age | Sex | Race | DOB | SSN | |
| Address | | | | | | Home Phone | | Cell Phone | |
| Code | Contact Name #4 | MI | Suffix | Age | Sex | Race | DOB | SSN | |
| Address | | | | | | Home Phone | | Cell Phone | |

Property Information:

| | | | | | | | |
|------------------------------------|----------|---------|------|----------|------|-------|-------|
| Value of Stolen Property | Currency | Jewelry | Furs | Clothing | Auto | Misc. | Total |
| Value of Stolen Property Recovered | | | | | | | |

Automobile Information:

| | Vehicle Code | Year | Make | Body Type | Model | Color | Registration | State | VIN |
|---|--------------|------|------|-----------|-------|-------|--------------|-------|-----|
| 1 | | | | | | | | | |
| 2 | | | | | | | | | |
| 3 | | | | | | | | | |
| 4 | | | | | | | | | |

Narrative:

On Thursday, August 5, 2021, at approximately 5:48 PM, I responded to the area of 1354 Teaneck Road on [redacted] I responded in motor patrol vehicle #16 with emergency lights and audible sirens activated.

Upon arrival, members of the Teaneck Volunteer Ambulance Corps. (TVAC) and Holy Name Medical Center (HNMC) Advanced Life Support (ALS) #301 responded to assist. Patient was subsequently transported to Holy Name Medical Center.

Officer of Record: Date: Other Reports Filed: Reviewed By:

| | | | |
|--------------------|----------|---|-----------|
| PO Kevin Gibbs 363 | 08/05/21 | MVA Arrest DV DWI DWIQ Tow SD CI TRO SHA Prop. Video UOF Prst Supp Juv Bias Pris | cantinori |
|--------------------|----------|---|-----------|



Teaneck Police Department

900 Teaneck Rd, Teaneck, NJ 07666

Phone: 201-837-2600 Fax: 201-837-1880 Mun. Code: 0260

Incident Report



Incident Details:

| | | | | | | | | | |
|-------------|---------------|---------------|---------------|---------------|-----------------------------------|---------------|---------------|-----|-----------|
| Case Number | Time Reported | Date Reported | Time Occurred | Date Occurred | Occurrence Between Date / Time of | Time Occurred | Date Occurred | 911 | Completed |
| 21-051644 | 13:44 | 09/18/21 | 13:44 | 09/18/21 | | | | X | X |

Incident Type:

Medical Emergency

Incident Location:

Street # Street Name Intersection / Cross Street of:
 1354 Teaneck Road Teaneck Road / Garden St
 Business / Common Location Name

Contact Information: Victim, Suspect, Complainant, Witness, Driver, Arrest, Driver, Must be at least 18

[Redacted Contact Information]

| Code | Contact Name #3 | MI | Suffix | Age | Sex | Race | DOB | SSN |
|------------|-----------------|----|------------|-----|-----|------|-----|-----|
| Address | | | | | | | | |
| Home Phone | | | Cell Phone | | | | | |
| Address | | | | | | | | |
| Home Phone | | | Cell Phone | | | | | |
| Address | | | | | | | | |
| Home Phone | | | Cell Phone | | | | | |

Property Information:

| | | | | | | | |
|------------------------------------|----------|---------|------|----------|------|-------|-------|
| Value of Stolen Property | Currency | Jewelry | Furs | Clothing | Auto | Misc. | Total |
| Value of Stolen Property Recovered | | | | | | | |

Automobile Information:

| 1 | Vehicle Code | Year | Make | Body Type | Model | Color | Registration | State | VIN |
|---|--------------|------|------|-----------|-------|-------|--------------|-------|-----|
| 2 | | | | | | | | | |
| 3 | | | | | | | | | |
| 4 | | | | | | | | | |

Narrative:

On Saturday, September 18, 2021, at approximately 1:44 PM, I responded to the area of 1354 Teaneck Road on a report of a [Redacted]. I responded in motor patrol vehicle #10 with emergency lights, audible sirens and arbitrator activated.

Upon arrival, the male party reported his leg gave out while walking on the sidewalk, causing him to fall. At this time, members of the Teaneck Volunteer Ambulance Corps. (TVAC) and Teaneck Fire Department (TFD) responded to assist. Patient was subsequently transported to Holy Name Medical Center (HNMC).

Officer of Record: PO Kevin Gibbs 363 Date: 09/18/21 Other Reports Filed: MVA Arrest DV DWI DWIQ Tow SD CI TRO Reviewed By: ttully

| | | | | | | | | | | | |
|--------------------|----------|-----|--------|-------|-----|------|------|-----|------|------|--------|
| PO Kevin Gibbs 363 | 09/18/21 | MVA | Arrest | DV | DWI | DWIQ | Tow | SD | CI | TRO | ttully |
| | | SHA | Prop. | Video | UOF | Prst | Supp | Juv | Bias | Pris | |



Teaneck Police Department

900 Teaneck Rd, Teaneck, NJ 07666

Phone: 201-837-2600 Fax: 201-837-1880 Mun. Code: 0260

Incident Report



Incident Details:

| | | | | | | | | | |
|-------------|---------------|---------------|---------------|---------------|-----------------------------------|---------------|---------------|-----|-----------|
| Case Number | Time Reported | Date Reported | Time Occurred | Date Occurred | Occurrence Between Date / Time of | Time Occurred | Date Occurred | 911 | Completed |
| 22-013846 | 17:43 | 03/10/22 | 17:43 | 03/10/22 | | | | X | X |

Incident Type:

Disturbance / Noise Complaint

Incident Location:

Street # Street Name Intersection / Cross Street of:
 1354 Teaneck Road Route 4 East
 Business / Common Location Name

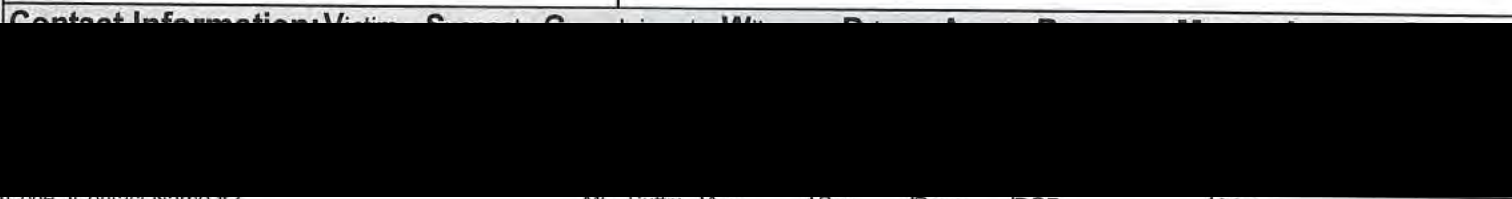

| | | | | | | | | |
|---------|-----------------|----|--------|-----|-----|------------|------------|-----|
| Code | Contact Name #2 | MI | Suffix | Age | Sex | Race | DOB | SSN |
| Address | | | | | | Home Phone | Cell Phone | |
| Code | Contact Name #3 | MI | Suffix | Age | Sex | Race | DOB | SSN |
| Address | | | | | | Home Phone | Cell Phone | |
| Code | Contact Name #4 | MI | Suffix | Age | Sex | Race | DOB | SSN |
| Address | | | | | | Home Phone | Cell Phone | |

Property Information:

| | | | | | | | |
|------------------------------------|----------|---------|------|----------|------|-------|-------|
| Value of Stolen Property | Currency | Jewelry | Furs | Clothing | Auto | Misc. | Total |
| Value of Stolen Property Recovered | | | | | | | |

Automobile Information:

| 1 | Vehicle Code | Year | Make | Body Type | Model | Color | Registration | State | VIN |
|---|--------------|------|------|-----------|-------|-------|--------------|-------|-----|
| 2 | | | | | | | | | |
| 3 | | | | | | | | | |
| 4 | | | | | | | | | |

Narrative:

On Thursday, March 10, 2022, 2022, at approximately 11:10 A.M., P.O. J. Pinsdorf #353, P.O. K. Gibbs #363, and I responded to 1354 Teaneck Road on a report of a verbal dispute. I responded in motor patrol vehicle #15 with my emergency lights, audible sirens and Mobile Video Recorder (MVR) activated.

| | | | | | | | | | | | |
|---------------------------|--------------|-----------------------------|--------|-------|-----|------|------|-----|------|---------------------|----------|
| Officer of Record: | Date: | Other Reports Filed: | | | | | | | | Reviewed By: | |
| PO Aundra Ellington 376 | 03/10/22 | MVA | Arrest | DV | DWI | DWIQ | Tow | SD | CI | TRO | rboswell |
| | | SHA | Prop. | Video | UOF | Prst | Supp | Juv | Bias | Pris | |



Teaneck Police Department

900 Teaneck Rd, Teaneck, NJ 07666

Phone: 201-837-2600 Fax: 201-837-1880 Mun. Code: 0260

Incident Report



Narrative Continued (Page 2)

Case Number

22-013846

Upon my arrival, I spoke with [REDACTED] who reported that he got into a verbal dispute with a unknown male party, who then punched his window and left the scene [REDACTED] vehicle was not damaged due to the dispute and he did not want to sign complaints at this time.

Submitted By: P.O. A. Ellington #376

Officer of Record:

Date:

PO Aundra Ellington 376

03/10/22



Teaneck Police Department

900 Teaneck Rd, Teaneck, NJ 07666

Phone: 201-837-2600 Fax: 201-837-1880 Mun. Code: 0260

CAD Report



Incident Details: Incident Location: Disposition

| | | | | |
|--------------|-------|----------|---------------------------------|-----------------|
| Case Number | Time | Date | Address | Disposition |
| PD-17-031829 | 19:19 | 08/28/17 | 1352 TEANECK ROAD, TEANECK TWP, | Accident Report |

Incident Type: Dispatched By Created By

| | | |
|--------------------------|-------|-------|
| Auto Accident: Hit & Run | Dkazm | Dkazm |
|--------------------------|-------|-------|

| | | | | | | | |
|------|---------|------|---------|------|---------|------|---------|
| Unit | Officer | Unit | Officer | Unit | Officer | Unit | Officer |
| 340 | Jmeyer | | | | | | |

| | | | |
|---------------|-----------------|--------------|--------------|
| Time Received | Time Dispatched | Time Arrived | Time Cleared |
| 1919 | 1920 | 1920 | 1920 |

Contact Information:

| Role | Contact Name | Address | DOB | Sex | Race | Phone |
|------|--------------|---------|-----|-----|------|-------|
|------|--------------|---------|-----|-----|------|-------|

| | | | | | | |
|--|--|--|--|--|--|--|
| | | | | | | |
|--|--|--|--|--|--|--|

| | | | | | | |
|--|--|--|--|--|--|--|
| | | | | | | |
|--|--|--|--|--|--|--|

| | | | | | | |
|--|--|--|--|--|--|--|
| | | | | | | |
|--|--|--|--|--|--|--|

| | | | | | | |
|--|--|--|--|--|--|--|
| | | | | | | |
|--|--|--|--|--|--|--|

| | | | | | | |
|--|--|--|--|--|--|--|
| | | | | | | |
|--|--|--|--|--|--|--|

| | | | | | | |
|--|--|--|--|--|--|--|
| | | | | | | |
|--|--|--|--|--|--|--|

| | | | | | | |
|--|--|--|--|--|--|--|
| | | | | | | |
|--|--|--|--|--|--|--|

| | | | | | | |
|--|--|--|--|--|--|--|
| | | | | | | |
|--|--|--|--|--|--|--|

| | | | | | | |
|--|--|--|--|--|--|--|
| | | | | | | |
|--|--|--|--|--|--|--|

Auto Information:

| | | | | | | |
|--------------|-------|------|-------|-------|------|-----|
| Registration | State | Make | Model | Color | Year | VIN |
|--------------|-------|------|-------|-------|------|-----|

| | | | | | | |
|--------|----|------|-----|-----|------|-------------------|
| G42FCF | NJ | LEXS | S30 | SIL | 2003 | JTHBF30G336023699 |
|--------|----|------|-----|-----|------|-------------------|

| | | | | | | |
|--|--|--|--|--|--|--|
| | | | | | | |
|--|--|--|--|--|--|--|

| | | | | | | |
|--|--|--|--|--|--|--|
| | | | | | | |
|--|--|--|--|--|--|--|

Summonses:

| | | | | |
|---------------|------|-----------|------|---------|
| Ticket Number | Date | Violation | Name | Officer |
|---------------|------|-----------|------|---------|

| | | | | |
|--|--|--|--|--|
| | | | | |
|--|--|--|--|--|

| | | | | |
|--|--|--|--|--|
| | | | | |
|--|--|--|--|--|

| | | | | |
|--|--|--|--|--|
| | | | | |
|--|--|--|--|--|

| | | | | |
|--|--|--|--|--|
| | | | | |
|--|--|--|--|--|

| | | | | |
|--|--|--|--|--|
| | | | | |
|--|--|--|--|--|

Narrative:

Input dkazm 08 28 2017 19 19 57 Edited dkazm 08 28 2017 19 19 57 SEE REPORT



Teaneck Police Department

900 Teaneck Rd, Teaneck, NJ 07666

Phone: 201-837-2600 Fax: 201-837-1880 Mun. Code: 0260

CAD Report



| Incident Details: | | | Incident Location: | | Disposition |
|-------------------|-------|----------|---------------------------------|--|------------------|
| Case Number | Time | Date | Address | | Disposition |
| PD-17-039012 | 18:57 | 10/24/17 | 1352 TEANECK ROAD, TEANECK TWP, | | Report Completed |

| Incident Type: | | | | Dispatched By | | Created By | |
|-------------------|---------|-----------------|---------|---------------|---------|--------------|---------|
| Credit Card Fraud | | | | Lmeek | | Dkazm | |
| Unit | Officer | Unit | Officer | Unit | Officer | Unit | Officer |
| 345 | Vkell | 321 | Rdiaz | | | | |
| Time Received | | Time Dispatched | | Time Arrived | | Time Cleared | |
| 1857 | | 1901 | | 1915 | | 1931 | |

| Contact Information: | | | | | |
|----------------------|--------------|---------|-----|-----|------------|
| Role | Contact Name | Address | DOB | Sex | Pass Photo |

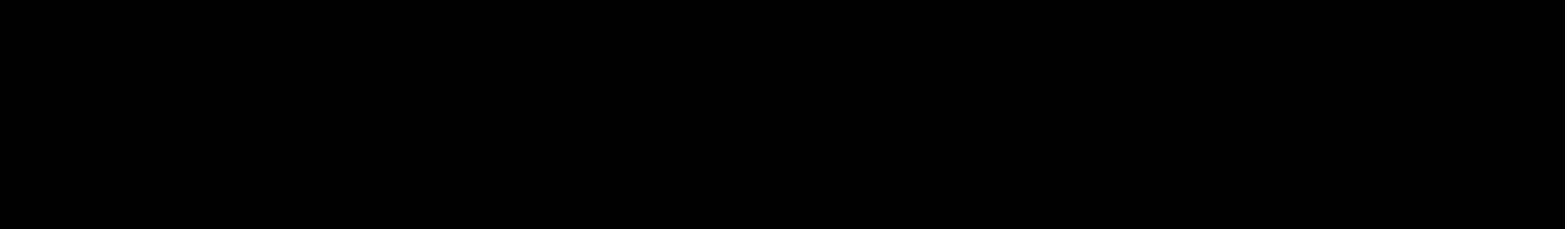

| Auto Information: | | | | | | |
|-------------------|-------|------|-------|-------|------|-----|
| Registration | State | Make | Model | Color | Year | VIN |

| |
|--|
| |
| |
| |
| |
| |

| Summonses: | | | | |
|---------------|------|-----------|------|---------|
| Ticket Number | Date | Violation | Name | Officer |

| |
|--|
| |
| |
| |
| |
| |

Narrative:

Input lmeek 10 24 2017 18 58 49 Edited lmeek 10 24 2017 18 58 49 THEFT OF SERVICES PARTY TRIED TO PAY FOR LIQOUR WITH A FRAUD CARD 10 MINS IN THE PAST UNABLE TO PROVIDE DESCRIPTION Input lmeek 10 24 2017 18 58 59 Edited lmeek 10 24 2017 18 58 59 OWNER KNOWS PARTY HAS DONE THIS IN THE PAST Input dkazm 10 24 2017 19 31 24 Edited dkazm 10 24 2017 19 31 24 10-8 WITH A REPORT



Teaneck Police Department

900 Teaneck Rd, Teaneck, NJ 07666

Phone: 201-837-2600 Fax: 201-837-1880 Mun. Code: 0260



Incident Report

| Incident Details: | | | Incident Location: | Disposition |
|-------------------|-------|----------|---------------------------------|------------------|
| Case Number | Time | Date | Address | Disposition |
| PD-17-039012 | 18:57 | 10/24/17 | 1352 TEANECK ROAD, TEANECK TWP, | Report Completed |

| Incident Type: | |
|-------------------|--|
| Credit Card Fraud | |

| Narrative | Officer | Approving Officer |
|-----------|---------|-------------------|
| | vkell | kmarr |

On Tuesday October 24 2017 at approximately 7 57 PM Officer R. Diaz 321 and I responded to 1352 Teaneck Road H S Discount Liquors on a report of a theft. Upon our arrival I spoke with the manager [REDACTED]. He reported that his associate was ringing up a customer that was making a large purchase of 456.66. The associate bagged the merchandise and the customer paid for the items with a credit card. The associate did not ask for identification when the customer paid with the credit card. The customer was then requested to sign a receipt for the merchandise. He signed the store s copy of the receipt then he took that same copy and left the store. He did not sign the merchant copy. When the manager looked on the video surveillance he realized that he had dealt with this individual in the past. Once I viewed the surveillance I immediately identified the customer as [REDACTED]. [REDACTED] has been involved in numerous past fraud theft investigations. The manager had a copy of the merchant copy that was unsigned. The unsigned receipt had the name [REDACTED] on the bottom of the receipt. This confirmed that the credit card did not belong to [REDACTED]. The manager gave us three receipts the first was the unsigned receipt for payment the second was a summary with credit card number and the third was a list of the items purchased. The following items on the receipt were One Case of Corona containing 12 bottles valued at 16.99. One Bottle of Redd s Wicked Black valued at 2.10. Two Cases of Johnnie Walker valued at 399.98. One 100 pack of Newport Cigarettes valued at 8.23. The manager was able to access the camera onsite. He informed us that he would put the video onto a USB drive and will drop it off at a later date to HQ. He also sent a copy of the video to my work email and I forwarded it to Detective Kazmierczak of the Detective Bureau. Back at Headquarters I completed the Victim Notification Form. I placed the three receipts into a clear heat sealed plastic bag with my signature signed across the seal. On the front of the bag I wrote in black marker PD-17-039012 and 10 24 17 I secured this evidence in the Locker 142. P.O.Victoria Kellman 345



Teaneck Police Department

900 Teaneck Rd, Teaneck, NJ 07666

Phone: 201-837-2600 Fax: 201-837-1880 Mun. Code: 0260

CAD Report



| Incident Details: | | | Incident Location: | | Disposition | |
|--------------------------|---------|-----------------|---------------------------------|--------------|------------------|--------------|
| Case Number | Time | Date | Address | | Disposition | |
| PD-18-002200 | 16:53 | 01/16/18 | 1352 TEANECK ROAD, TEANECK TWP. | | Report Completed | |
| Incident Type: | | | Dispatched By | | Created By | |
| Dom Viol Involv/ Assault | | | Bcoym | | Danti | |
| Unit | Officer | Unit | Officer | Unit | Officer | Officer |
| 348 | Jcano | 324 | Rfact | 348 | Jcano | 272 Jgarl |
| Time Received | | Time Dispatched | | Time Arrived | | Time Cleared |
| 1653 | | 1656 | | 1657 | | 1705 |
| Contact Information: | | | | | | |

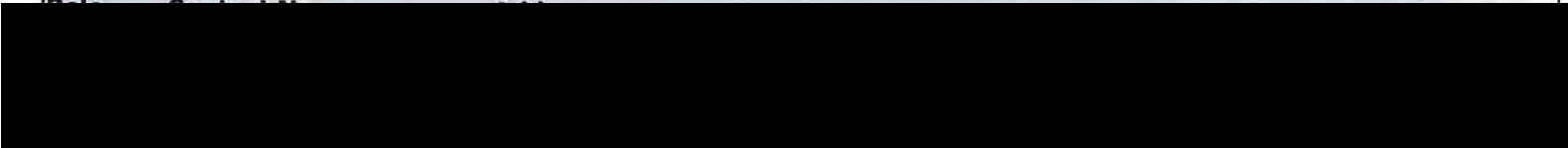

| |
|--|
| |
| |
| |
| |
| |
| |
| |
| |
| |
| |

| Auto Information: | | | | | | |
|-------------------|-------|------|-------|-------|------|-----|
| Registration | State | Make | Model | Color | Year | VIN |
| [Redacted] | | | | | | |
| | | | | | | |
| | | | | | | |
| | | | | | | |

| Summonses: | | | | |
|---------------|------|-----------|------|---------|
| Ticket Number | Date | Violation | Name | Officer |
| | | | | |
| | | | | |
| | | | | |
| | | | | |
| | | | | |

| Narrative: |
|------------|
| [Redacted] |



Teaneck Police Department

900 Teaneck Rd, Teaneck, NJ 07666

Phone: 201-837-2600 Fax: 201-837-1880 Mun. Code: 0260



Incident Report

| Incident Details: | | | Incident Location: | Disposition |
|--------------------------|-------|----------|---------------------------------|------------------|
| Case Number | Time | Date | Address | Disposition |
| PD-18-002200 | 16:53 | 01/16/18 | 1352 TEANECK ROAD, TEANECK TWP, | Report Completed |
| Incident Type: | | | | |
| Dom Viol Involv/ Assault | | | | |
| Narrative | | Officer | Approving Officer | |
| | | jcano | dalco | |

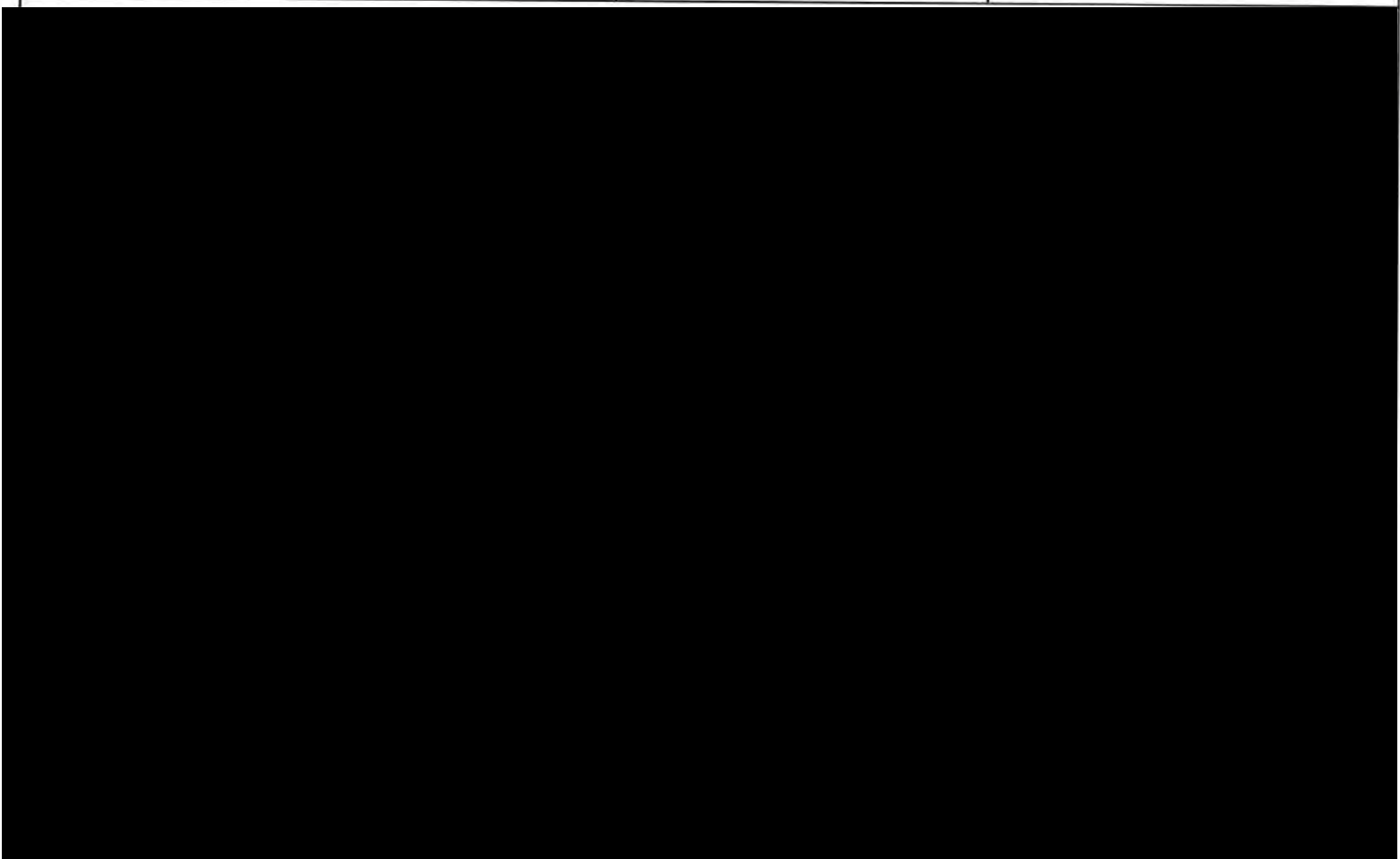



Teaneck Police Department

900 Teaneck Rd, Teaneck, NJ 07666

Phone: 201-837-2600 Fax: 201-837-1880 Mun. Code: 0260

Incident Report



Incident Details:

| | | | | | | | | | |
|-------------|---------------|---------------|---------------|---------------|-----------------------------------|---------------|---------------|-----|-----------|
| Case Number | Time Reported | Date Reported | Time Occurred | Date Occurred | Occurrence Between Date / Time of | Time Occurred | Date Occurred | 911 | Completed |
| 21-027947 | 20:11 | 05/29/21 | 20:11 | 05/29/21 | | | | | X |

Incident Type:

Medical Emergency

Incident Location:

| | | |
|---------------------------------|--------------|---------------------------------|
| Street # | Street Name | Intersection / Cross Street of: |
| 1350 | Teaneck Road | Teaneck Road / Garden St |
| Business / Common Location Name | | |

Contact Information: Victim Suspect Complainant Witness Driver Arrest Passenger Missing Involved Other

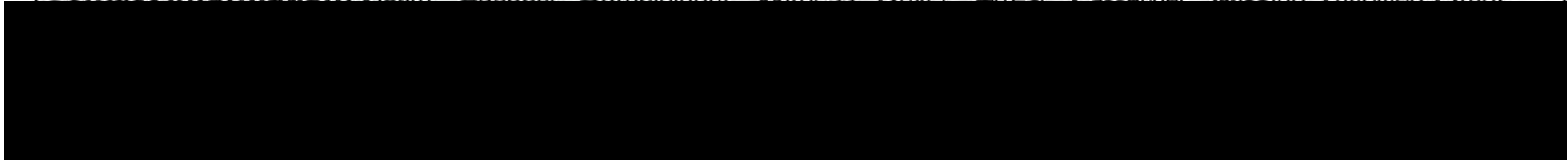

| | | | | | | | | |
|------|-----------------|----|--------|-----|-----|------|-----|-----|
| Code | Contact Name #2 | MI | Suffix | Age | Sex | Race | DOB | SSN |
|------|-----------------|----|--------|-----|-----|------|-----|-----|

| | | | | | | | |
|---------|--|--|--|--|--|------------|------------|
| Address | | | | | | Home Phone | Cell Phone |
|---------|--|--|--|--|--|------------|------------|

| | | | | | | | | |
|------|-----------------|----|--------|-----|-----|------|-----|-----|
| Code | Contact Name #3 | MI | Suffix | Age | Sex | Race | DOB | SSN |
|------|-----------------|----|--------|-----|-----|------|-----|-----|

| | | | | | | | |
|---------|--|--|--|--|--|------------|------------|
| Address | | | | | | Home Phone | Cell Phone |
|---------|--|--|--|--|--|------------|------------|

| | | | | | | | | |
|------|-----------------|----|--------|-----|-----|------|-----|-----|
| Code | Contact Name #4 | MI | Suffix | Age | Sex | Race | DOB | SSN |
|------|-----------------|----|--------|-----|-----|------|-----|-----|

| | | | | | | | |
|---------|--|--|--|--|--|------------|------------|
| Address | | | | | | Home Phone | Cell Phone |
|---------|--|--|--|--|--|------------|------------|

Property Information:

| | | | | | | | |
|------------------------------------|----------|---------|------|----------|------|-------|-------|
| Value of Stolen Property | Currency | Jewelry | Furs | Clothing | Auto | Misc. | Total |
| Value of Stolen Property Recovered | | | | | | | |

Automobile Information:

| 1 | Vehicle Code | Year | Make | Body Type | Model | Color | Registration | State | VIN |
|---|--------------|------|------|-----------|-------|-------|--------------|-------|-----|
| 2 | | | | | | | | | |
| 3 | | | | | | | | | |
| 4 | | | | | | | | | |

Narrative:

On Saturday, May 29, 2021, at approximately 8:11 PM, Teaneck Volunteer Ambulance Corps (TVAC), Officer A. Bullock #360, and I were dispatched to 1350 Teaneck Road on a report of a party needing an ambulance. I responded with emergency lights, audible sirens, and the Arbitrator Mobile Video Recorder Activated.



Officer of Record: Date: Other Reports Filed: Reviewed By:

| | | | |
|-----------------------|----------|---|----------|
| PO Justin Cochran 367 | 05/29/21 | MVA Arrest DV DWI DWIQ Tow SD CI TRO SHA Prop. Video UOF Prst Supp Juv Bias Pris | rmorales |
|-----------------------|----------|---|----------|



Teaneck Police Department

900 Teaneck Rd, Teaneck, NJ 07666

Phone: 201-837-2600 Fax: 201-837-1880 Mun. Code: 0260

Incident Report



Narrative Continued (Page 2)

Case Number

21-027047

Submitted By: Officer Justin Cochran #367

Officer of Record:

Date:

PO Justin Cochran 367

05/29/21



Teaneck Police Department

900 Teaneck Rd, Teaneck, NJ 07666

Phone: 201-837-2600 Fax: 201-837-1880 Mun. Code: 0260

Incident Report



Incident Details:

| | | | | | | | | | |
|-------------|---------------|---------------|---------------|---------------|-----------------------------------|---------------|---------------|-----|-----------|
| Case Number | Time Reported | Date Reported | Time Occurred | Date Occurred | Occurrence Between Date / Time of | Time Occurred | Date Occurred | 911 | Completed |
| 19-053796 | 16:34 | 10/01/19 | 16:34 | 10/01/19 | | | | | X |

Incident Type:

MV Crash

Incident Location:

Street # Street Name Intersection / Cross Street of:
 1348 Teaneck Road Teaneck Road / Garden St
 Business / Common Location Name

Contact Information: Victim Suspect Complainant Witness Driver Arrest Passenger Missing Involved Other

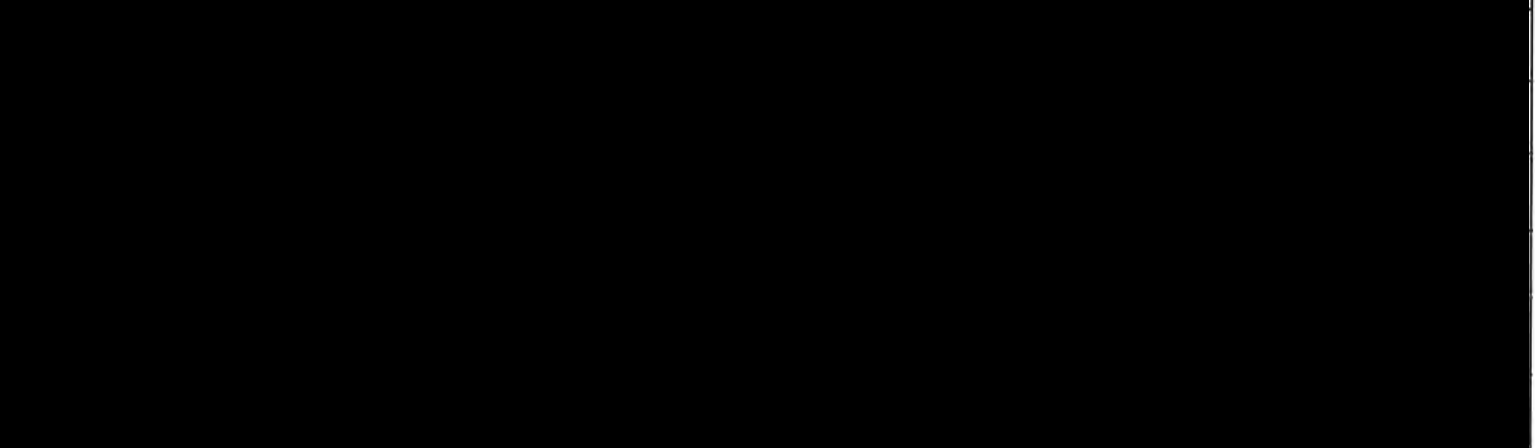

| | | | | | | | | |
|---------|-----------------|----|--------|-----|-----|------------|-----|------------|
| Code | Contact Name #4 | Mi | Suffix | Age | Sex | Race | DOB | SSN |
| Address | | | | | | Home Phone | | Cell Phone |

Property Information:

| | | | | | | | |
|------------------------------------|----------|---------|------|----------|------|-------|-------|
| Value of Stolen Property | Currency | Jewelry | Furs | Clothing | Auto | Misc. | Total |
| Value of Stolen Property Recovered | | | | | | | |

Automobile Information:

| | Vehicle Code | Year | Make | Body Type | Model | Color | Registration | State | VIN |
|---|--------------|------|--------|-----------|--------|-------|--------------|-------|-------------------|
| 1 | Veh. 1 | 07 | CHR | 4 DR | SEB | WT | F61KWY | NJ | 1C3LC46K27N655668 |
| 2 | Veh. 2 | 15 | CHEVRO | VN | EXPRES | NO- | 88672MG | NY | 1GCZGTCG8F1276023 |
| 3 | | | | | | | | | |
| 4 | | | | | | | | | |

Narrative:

See NJTR-1

Officer of Record: Date: Other Reports Filed: Reviewed By:

| | | | | | | | | | | |
|---------------------|----------|--------------|-------|-------|------|------|------|-----|------|----------|
| PO Zachary Reed 352 | 10/01/19 | MVA X Arrest | DV | DWI | DWIQ | Tow | SD | CI | TRO | pforrest |
| | | SHA | Prop. | Video | UOF | Prst | Supp | Juv | Bias | |

Page 1 of 2 Fatal Reportable Non-Reportable Change Report

New Jersey Police Crash Investigation Report

1. Case Number: **19-053796** 10. Crash Occurred On: **Teaneck Road** 11. Speed Limit: **25**

2. Police Dept. of Code: **Teaneck 01** 12. Route No. Suffix 13. Milepost: **25**

3. Station/Precinct: **01** 14. At Intersection with Feet Miles 15. N E S W of: **Garden St** 16. 18. To: 17. Cross Road Name/Route No. 18. Speed Limit: **25**

4. Date of Crash: **10/01/19** 5. Day of Week: **Th** 6. Time (use 2400 hrs.): **1634** 7. Municipality Code: **0260** 8. Total Killed: **0** 9. Total Injured: **0** 19. Ramp: From: To: 20. Route Name/Route No. 21. Latitude: **40 41 19** 22. Longitude: **74 02 19**

23. Veh. # 24. Policy No. **SNJ 000-5088-174-9** 25. NJ Ins. Code: **038** 26. Veh. # 27. Policy No. **MWTB 313092** 28. NJ Ins. Code: **263**

28. Driver's First Name: **Arthur J Lawson** 29. Sex: **M** 30. Eyes: **2** 31. State: **NJ** 32. Driver's License Number: **L0942 06171 12002** 33. DOB: **12/18/80** 34. Expires: **12/22**

58. Driver's First Name: **Cruz M Rodriguez** 59. Sex: **M** 60. Eyes: **2** 61. State: **NJ** 62. Driver's License Number: **R6094 14374 01752** 63. DOB: **01/22/75** 64. Expires: **01/20**

35. Owner's First Name: Same as Driver The Hallen 36. Number & Street: **4270 Austin Blvd** 37. City: **Island Park NY 11558**

38. Make: **CHR** 39. Model: **SEB** 40. Color: **WT** 41. Year: **07** 42. Plate No.: **F61KWY** 43. State: **NJ** 44. VIN: **1C3LC46K27N655668** 45. Expires: **01/20**

68. Make: **CHEVROL** 69. Model: **EXPRESS** 70. Color: **NO-** 71. Year: **15** 72. Plate No.: **88672MG** 73. State: **NY** 74. VIN: **1GCZGTCG8F1276023** 75. Expires: **09/21**

46. Vehicle Removed to: Driven Towed Disabled Towed Disabled & Impounded Left at Scene Towed Impounded

47. Authority: Owner Driver Police

48. Alcohol Drug Test: Given: No Yes Refused Type: Breath Blood Urine Results: **0.00** % Pending

49. Hazardous Material: None On Board Spill Hazard Class: Placard No.:

78. Alcohol Drug Test: Given: No Yes Refused Type: Breath Blood Urine Results: **0.00** % Pending

79. Hazardous Material: None On Board Spill Hazard Class: Placard No.:

60. Carrier No. USDOT MC/MX None 61. GVWR / GCWR (trucks & buses only) ≤ 10,000 lbs. 10,001 - 25,000 lbs. ≥ 25,001 lbs.

80. Carrier No. USDOT MC/MX None 81. GVWR / GCWR (trucks & buses only) ≤ 10,000 lbs. 10,001 - 25,000 lbs. ≥ 25,001 lbs.

82. Motor Carrier or Government Entity: Yes (if Yes, describe) No

135. Damage to Other Property: Yes (if Yes, describe) No

Oper. 136. Charge: _____ 137. Summons No.: _____ Oper. 138. Charge: _____ 139. Summons No.: _____

Oper. 140. Charge: _____ 141. Summons No.: _____ Oper. 142. Charge: _____ 143. Summons No.: _____

| | 83 | 84 | 85 | 86 | 87 | 88 | 89 | 90 | 91 | 92 | 93 | 94 | 95 | Names & Addresses of Occupants If Deceased, Date & Time of Death |
|---|------|------|------|------|------|------|------|------|------|------|------|------|------|---|
| A | 1 | 01 | 01 | 05 | 18 | M | ---- | ---- | 1 | 11 | 04 | ---- | ---- | Lawson, Arthur-24 Garden St, Teaneck, NJ 07666-5919 |
| B | 1 | 01 | 01 | 05 | 44 | M | ---- | ---- | 1 | 11 | 04 | ---- | ---- | Rodriguez, Cruz-143 W Clinton Ave, Bergenfield, NJ 07621-2730 |
| C | ---- | ---- | ---- | ---- | ---- | ---- | ---- | ---- | ---- | ---- | ---- | ---- | ---- | |
| D | ---- | ---- | ---- | ---- | ---- | ---- | ---- | ---- | ---- | ---- | ---- | ---- | ---- | |

New Jersey Police
Crash Investigation Report

Case Number
19-053796

Page 2 of 2

| | 83 | 84 | 85 | 86 | 87 | 88 | 89 | 90 | 91 | 92 | 93 | 94 | 95 | Names & Addresses of Occupants If Deceased, Date & Time of Death |
|---|-----|-----|-----|-----|-----|-----|-----|-----|-----|-----|-----|-----|-----|---|
| E | --- | --- | --- | --- | --- | --- | --- | --- | --- | --- | --- | --- | --- | ----- |
| F | --- | --- | --- | --- | --- | --- | --- | --- | --- | --- | --- | --- | --- | ----- |
| G | --- | --- | --- | --- | --- | --- | --- | --- | --- | --- | --- | --- | --- | ----- |
| H | --- | --- | --- | --- | --- | --- | --- | --- | --- | --- | --- | --- | --- | ----- |
| I | --- | --- | --- | --- | --- | --- | --- | --- | --- | --- | --- | --- | --- | ----- |
| J | --- | --- | --- | --- | --- | --- | --- | --- | --- | --- | --- | --- | --- | ----- |

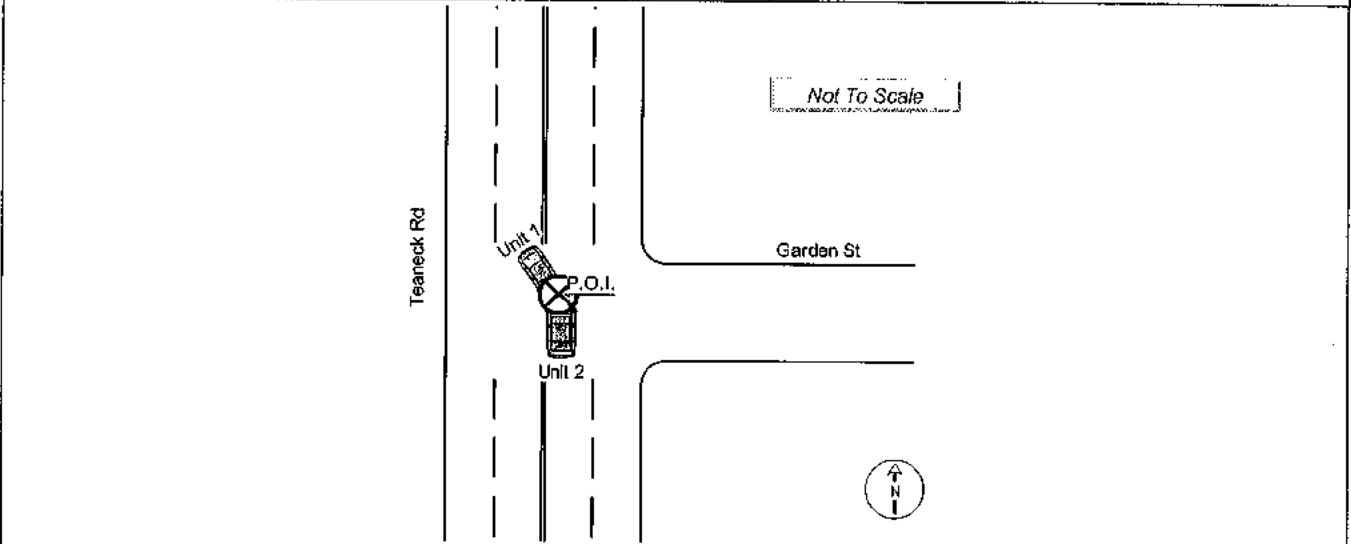

146. Crash Description/Narrative

The Driver of Vehicle 1 stated that he was attempting to make a left turn from Teaneck Road onto Garden Street. Traffic in the right lane traveling north came to a stop to allow him to turn. Vehicle 2 was traveling north in the left lane but did not come to a stop as the Driver of Vehicle 1 assumed he would, causing his vehicle to collide with Vehicle 2.

The Driver of Vehicle 2 stated he was traveling north on Teaneck Road in the left lane. Vehicle 1 was attempting to make a left turn in front of his vehicle to turn onto garden street. Vehicle 1 entered his lane of travel, colliding with his vehicle.

| | | | | |
|---|---------------------|---|----------------|---|
| 146. Officer's Signature PO Zachary Reed 352 | 147. Badge # 352 | 148. Reviewer Sgt. Patrick Forrest 271 | Badge # 271 | 149. Case Status <input type="checkbox"/> Pending <input checked="" type="checkbox"/> Complete |
|---|---------------------|---|----------------|---|



Teaneck Police Department

900 Teaneck Rd, Teaneck, NJ 07666

Phone: 201-837-2600 Fax: 201-837-1880 Mun. Code: 0260

Incident Report



| Incident Details: | | | | | | | | | |
|-------------------|---------------|---------------|---------------|---------------|-----------------------------------|---------------|---------------|-----|-----------|
| Case Number | Time Reported | Date Reported | Time Occurred | Date Occurred | Occurrence Between Date / Time of | Time Occurred | Date Occurred | 911 | Completed |
| 21-019544 | 16:45 | 04/17/21 | 16:45 | 04/17/21 | | | | X | X |

| Incident Type: | Incident Location: |
|-------------------|--|
| Medical Emergency | Street # Street Name 1348 Teaneck Road Intersection / Cross Street of: Garden St Business / Common Location Name |

Contact Information: Victim Suspect Complainant Witness Driver Arrest Passenger Missing Involved Other



| | | |
|---|------------|------------|
| Address | Home Phone | Cell Phone |
| Code Contact Name #3 MI Suffix Age Sex Race DOB SSN | | |
| Address | Home Phone | Cell Phone |
| Code Contact Name #4 MI Suffix Age Sex Race DOB SSN | | |
| Address | Home Phone | Cell Phone |

| Property Information: | | | | | | | |
|------------------------------------|----------|---------|------|----------|------|-------|-------|
| Value of Stolen Property | Currency | Jewelry | Furs | Clothing | Auto | Misc. | Total |
| Value of Stolen Property Recovered | | | | | | | |

| Automobile Information: | | | | | | | | | |
|-------------------------|--------------|------|------|-----------|-------|-------|--------------|-------|-----|
| 1 | Vehicle Code | Year | Make | Body Type | Model | Color | Registration | State | VIN |
| 2 | | | | | | | | | |
| 3 | | | | | | | | | |
| 4 | | | | | | | | | |

Narrative:

On Saturday, April 17, 2021, at approximately 4:45 PM, I responded to 1348 Teaneck Road on a report of a [redacted] I responded in motor patrol vehicle #16 in routine manner.

Upon arrival, members of the Teaneck Volunteer Ambulance Corps. (TVAC) responded to assist. Patient was subsequently transported to Holy Name Medical Center.

| Officer of Record: | Date: | Other Reports Filed: | Reviewed By: |
|--------------------|----------|---|--------------|
| PO Kevin Gibbs 363 | 04/17/21 | MVA Arrest DV DWI DWIQ Tow SD CI TRO SHA Prop. Video UOF Prst Supp Juv Bias Pris | pforrest |



Teaneck Police Department

900 Teaneck Rd, Teaneck, NJ 07666

Phone: 201-837-2600 Fax: 201-837-1880 Mun. Code: 0260

Incident Report



Incident Details:

| | | | | | | | | | |
|-------------|---------------|---------------|---------------|---------------|-----------------------------------|---------------|---------------|-----|-----------|
| Case Number | Time Reported | Date Reported | Time Occurred | Date Occurred | Occurrence Between Date / Time of | Time Occurred | Date Occurred | 911 | Completed |
| 22-011271 | 14:03 | 02/25/22 | 14:03 | 02/25/22 | | | | | X |

Incident Type:

MV Crash

Incident Location:

| | | |
|---------------------------------|--------------|---------------------------------|
| Street # | Street Name | Intersection / Cross Street of: |
| 1348 | Teaneck Road | |
| Business / Common Location Name | | |

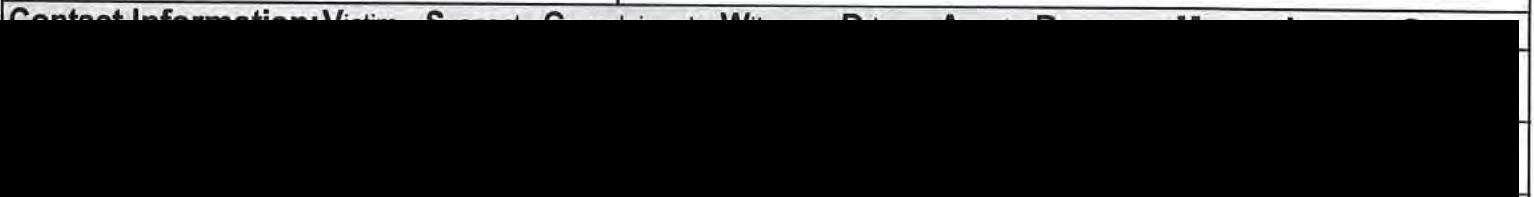

| | | | | | | | | |
|---------|-----------------|----|--------|-----|-----|------------|-----|------------|
| Code | Contact Name #2 | MI | Suffix | Age | Sex | Race | DOB | SSN |
| Address | | | | | | Home Phone | | Cell Phone |
| Code | Contact Name #3 | MI | Suffix | Age | Sex | Race | DOB | SSN |
| Address | | | | | | Home Phone | | Cell Phone |
| Code | Contact Name #4 | MI | Suffix | Age | Sex | Race | DOB | SSN |
| Address | | | | | | Home Phone | | Cell Phone |

Property Information:

| | | | | | | | |
|------------------------------------|----------|---------|------|----------|------|-------|-------|
| Value of Stolen Property | Currency | Jewelry | Furs | Clothing | Auto | Misc. | Total |
| Value of Stolen Property Recovered | | | | | | | |

Automobile Information:

| 1 | Vehicle Code | Year | Make | Body Type | Model | Color | Registration | State | VIN |
|---|--------------|------|------|-----------|-------|-------|--------------|-------|-------------------|
| | Veh. 1 | 18 | CHE | WAGON | TRV | BN | Y96JTL | NJ | 1GNEVJKW7JJ117947 |
| 2 | | | | | | | | | |
| 3 | | | | | | | | | |
| 4 | | | | | | | | | |

Narrative:

See NJTR-1

| | | | |
|---------------------------|--------------|---|---------------------|
| Officer of Record: | Date: | Other Reports Filed: | Reviewed By: |
| PO Rafael Vallejos 362 | 02/25/22 | MVA X Arrest DV DWI DWIQ Tow SD CI TRO SHA Prop. Video UOF Prst Supp Juv Bias Pris | cantinori |

New Jersey Police
Crash Investigation Report

Case Number
22-011271

Page 2 of 2

| | 83 | 84 | 85 | 86 | 87 | 88 | 89 | 90 | 91 | 92 | 93 | 94 | 95 | Names & Addresses of Occupants If Deceased, Date & Time of Death |
|---|-----|-----|-----|-----|-----|-----|-----|-----|-----|-----|-----|-----|-----|---|
| E | --- | --- | --- | --- | --- | --- | --- | --- | --- | --- | --- | --- | --- | ----- |
| F | --- | --- | --- | --- | --- | --- | --- | --- | --- | --- | --- | --- | --- | ----- |
| G | --- | --- | --- | --- | --- | --- | --- | --- | --- | --- | --- | --- | --- | ----- |
| H | --- | --- | --- | --- | --- | --- | --- | --- | --- | --- | --- | --- | --- | ----- |
| I | --- | --- | --- | --- | --- | --- | --- | --- | --- | --- | --- | --- | --- | ----- |
| J | --- | --- | --- | --- | --- | --- | --- | --- | --- | --- | --- | --- | --- | ----- |

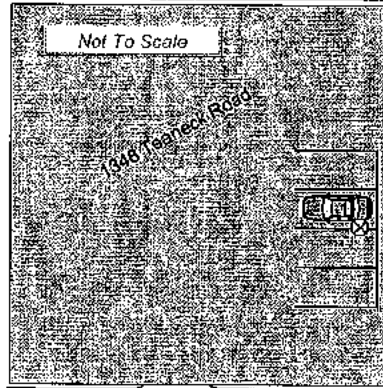

Teaneck Road

145. Crash Description/Narrative

Owner of vehicle 1 reported that he had parked his vehicle at approximately 3:00 a.m. on February 25, 2022, after he had returned home from work. When he returned to his vehicle at approximately 2:00 p.m. the same day he observed his vehicle had been struck on the driver rear side.

During my canvass of the area I determined that there was no cameras or witnesses. My observation of the vehicle confirmed that it had been side swipe however no paint transferred occurred to assist with the identification of the second vehicle.

146. Officer's Signature

PO Rafael Vallejos 362

147. Badge #

362

148. Reviewer

Sgt. Charles Antinori 326

Badge #

326

149. Case Status

Pending Complete



Teaneck Police Department

900 Teaneck Rd, Teaneck, NJ 07666

Phone: 201-837-2600 Fax: 201-837-1880 Mun. Code: 0260

Incident Report



| | | | | | | | | | |
|--------------------------|---------------|---------------|---------------|---------------|-----------------------------------|---------------|---------------|-----|-----------|
| Incident Details: | | | | | | | | | |
| Case Number | Time Reported | Date Reported | Time Occurred | Date Occurred | Occurrence Between Date / Time of | Time Occurred | Date Occurred | 911 | Completed |
| 18-033446 | 13:21 | 07/20/18 | 13:21 | 07/21/18 | | | | | X |

| | | | | | | | | | |
|-----------------------|--|--|---------------------------------|--|--|--|---------------------------------|--|--|
| Incident Type: | | | Incident Location: | | | | | | |
| Alarm - Burglar | | | Street # Street Name | | | | Intersection / Cross Street of: | | |
| Shoplifting 2C:20-11 | | | 1352 Teaneck Road | | | | Teaneck Road / Garden St | | |
| | | | Business / Common Location Name | | | | | | |

Contact Information: Victim: _____ Suspect: _____ Complainant: _____ Witness: _____ Driver: _____ Arrest: _____

| | | | | | | | | |
|---------|-----------------|----|--------|-----|-----|------------|-----|------------|
| Code | Contact Name #2 | MI | Suffix | Age | Sex | Race | DOB | SSN |
| Address | | | | | | Home Phone | | Cell Phone |
| Code | Contact Name #3 | MI | Suffix | Age | Sex | Race | DOB | SSN |
| Address | | | | | | Home Phone | | Cell Phone |
| Code | Contact Name #4 | MI | Suffix | Age | Sex | Race | DOB | SSN |
| Address | | | | | | Home Phone | | Cell Phone |

| | | | | | | | |
|------------------------------------|----------|---------|------|----------|------|--------|--------|
| Property Information: | | | | | | | |
| Value of Stolen Property | Currency | Jewelry | Furs | Clothing | Auto | Misc. | Total |
| | | | | | | \$5.00 | \$5.00 |
| Value of Stolen Property Recovered | | | | | | | |

| | | | | | | | | | |
|--------------------------------|--------------|------|------|-----------|-------|-------|--------------|-------|-----|
| Automobile Information: | | | | | | | | | |
| 1 | Vehicle Code | Year | Make | Body Type | Model | Color | Registration | State | VIN |
| 2 | | | | | | | | | |
| 3 | | | | | | | | | |
| 4 | | | | | | | | | |

Narrative:
 On Friday, July 21, 2018, at 3:21 PM, I responded, on a delayed response because of call volume, to 1352 Teaneck Road, R&H Liquor, along with Officer Peters, on a report of an activated burglar alarm.
 Upon our arrival, I met with [REDACTED] the store owner. He reported that he activated the alarm button because a black male, in his late twenties, about 6' 3", 185 lbs., with dreadlock hair and a white T shirt, tried to shoplift a spray bottle of Blunt air freshener, valued at 5.00, from the counter. He caught him putting it in his knapsack while on line to pay, when he was dealing with other customers.

| | | | | | | | | | | | | |
|---------------------------|--------------|-----------------------------|--------|-------|-----|------|------|-----|------|------|--|---------------------|
| Officer of Record: | Date: | Other Reports Filed: | | | | | | | | | | Reviewed By: |
| PO Raymond Byrne 234 | 07/20/18 | MVA | Arrest | DV | DWI | DWIQ | Tow | SD | CI | TRO | | dalcott |
| | | SHA | Prop. | Video | UOF | Prst | Supp | Juv | Bias | Pris | | |



Teaneck Police Department

900 Teaneck Rd, Teaneck, NJ 07666

Phone: 201-837-2600 Fax: 201-837-1880 Mun. Code: 0260

Incident Report



Narrative Continued (Page 2)

Case Number

18-033446

[REDACTED] was able to get the item back, after grabbing his bag while verbally arguing with the actor. Mr. [REDACTED] further reported that he has seen the party in the neighborhood and believes that he lives at 22 West Englewood Avenue.

[REDACTED] does not wish to sign a complaint at this time, but does not want the male party back in his store and has told him so.

A video of the incident was able to be e mailed to this officer and is contained in this report.

Officer of Record:

Date:

PO Raymond Byrne 234

07/20/18



Teaneck Police Department

900 Teaneck Rd, Teaneck, NJ 07666

Phone: 201-837-2600 Fax: 201-837-1880 Mun. Code: 0260

Incident Report



Incident Details:

| | | | | | | | | | |
|-------------|---------------|---------------|---------------|---------------|-----------------------------------|---------------|---------------|-----|-----------|
| Case Number | Time Reported | Date Reported | Time Occurred | Date Occurred | Occurrence Between Date / Time of | Time Occurred | Date Occurred | 911 | Completed |
| 18-035108 | 12:18 | 07/29/18 | 23:00 | 07/28/18 | | 12:00 | 07/29/18 | | X |

Incident Type:

Attempted / Burglary 2C:18-2

Incident Location:

Street # Street Name Intersection / Cross Street of:
 1352 Teaneck Rd Teaneck Road / Garden St
 Business / Common Location Name
 H & R Liquors

Contact Information: Victim Suspect Complainant Witness Driver Arrest Recipient Missing Injured Other



| | | | | | | | | |
|---------|-----------------|----|--------|-----|-----|------------|-----|------------|
| Code | Contact Name #3 | MI | Suffix | Age | Sex | Race | DOB | SSN |
| Address | | | | | | Home Phone | | Cell Phone |
| Code | Contact Name #4 | MI | Suffix | Age | Sex | Race | DOB | SSN |
| Address | | | | | | Home Phone | | Cell Phone |

Property Information:

| | | | | | | | |
|------------------------------------|----------|---------|------|----------|------|-------|-------|
| Value of Stolen Property | Currency | Jewelry | Furs | Clothing | Auto | Misc. | Total |
| Value of Stolen Property Recovered | | | | | | | |

Automobile Information:

| 1 | Vehicle Code | Year | Make | Body Type | Model | Color | Registration | State | VIN |
|---|--------------|------|------|-----------|-------|-------|--------------|-------|-----|
| 2 | | | | | | | | | |
| 3 | | | | | | | | | |
| 4 | | | | | | | | | |

Narrative:

On Sunday, July 29, 2018, at approximately 12:18 PM, Sgt. Croonquist #266 and I responded to 1352 Teaneck Road, H&R liquors, to investigate the report of a broken front door.

Upon arrival, we spoke with the business owner [REDACTED] who reported that she found the outer pane of glass from the double pane front glass door, broken at approximately 12:00 PM. She reported that she and her husband closed the store at approximately 11:00 PM the night before, on Saturday, July 28, 2018, and the door was not damaged. She reported that she doesn't know who could have broken the pane, since she doesn't have any issues with anyone. No entry was made to the business and no proceeds were taken.

| | | | | | | | | | | | | |
|---------------------------|--------------|-----------------------------|--------|-------|-----|------|--------|-----|------|------|--|---------------------|
| Officer of Record: | Date: | Other Reports Filed: | | | | | | | | | | Reviewed By: |
| PO Patrick Haase 341 | 07/29/18 | MVA | Arrest | DV | DWI | DWIQ | Tow | SD | CI | TRO | | pforrest |
| | | SHA | Prop. | Video | UOF | Prst | Supp 1 | Juv | Bias | Pris | | |



Teaneck Police Department

900 Teaneck Rd, Teaneck, NJ 07666

Phone: 201-837-2600 Fax: 201-837-1880 Mun. Code: 0260

Incident Report



Narrative Continued (Page 2)

Case Number

18-035108

██████████ stated that her husband, ██████████ would be in around 4:00 PM and that he would be able to make a copy of the surveillance video, unfortunately she is not familiar with the surveillance system. A Victim Notification Form was filled out, faxed to the Bergen County Victim/Witness Advocacy and ██████████ received the pink copy.

At approximately 4:45 PM, I responded back to the aforementioned address to secure surveillance video evidence from ██████████. He reported that he did not have anything to download the surveillance video onto, but he would the following day, I was able to view the surveillance video at this time.

The incident occurred at approximately 5:02 AM. Two actors wearing gray hooded sweaters, with the hoods over their heads and their faces covered by bandanas, approached the store from W. Englewood Avenue. They walked past the store, while looking at the outside surveillance camera as they passed underneath it. Shortly after checking out the camera, they turned back around and walked up to the window. One of the actors threw an object at the door, then both parties attempted to break the second pane but were unsuccessful. They left the area, heading back towards W. Englewood Avenue and disappearing out of the camera's view.

Reporting Officer: Patrick Haase #341.

Officer of Record:

Date:

PO Patrick Haase 341

07/29/18



Teaneck Police Department

900 Teaneck Rd, Teaneck, NJ 07666

Phone: 201-837-2600 Fax: 201-837-1880 Mun. Code: 0260

Incident Report



| Incident Details: | | | | | | | | | |
|-------------------|---------------|---------------|---------------|---------------|-----------------------------------|---------------|---------------|-----|-----------|
| Case Number | Time Reported | Date Reported | Time Occurred | Date Occurred | Occurrence Between Date / Time of | Time Occurred | Date Occurred | 911 | Completed |
| 18-035354 | 21:09 | 07/30/18 | 18:30 | 07/30/18 | | 21:00 | 07/30/18 | | X |

| Incident Type: | Incident Location: |
|----------------|--|
| MV Crash | Street # Street Name 1352 Teaneck Road Intersection / Cross Street of: Teaneck Road / Garden St Business / Common Location Name H & R Liquors |

Contact Information: Victim Suspect Complainant Witness Driver Arrest Passenger Missing Involved Other

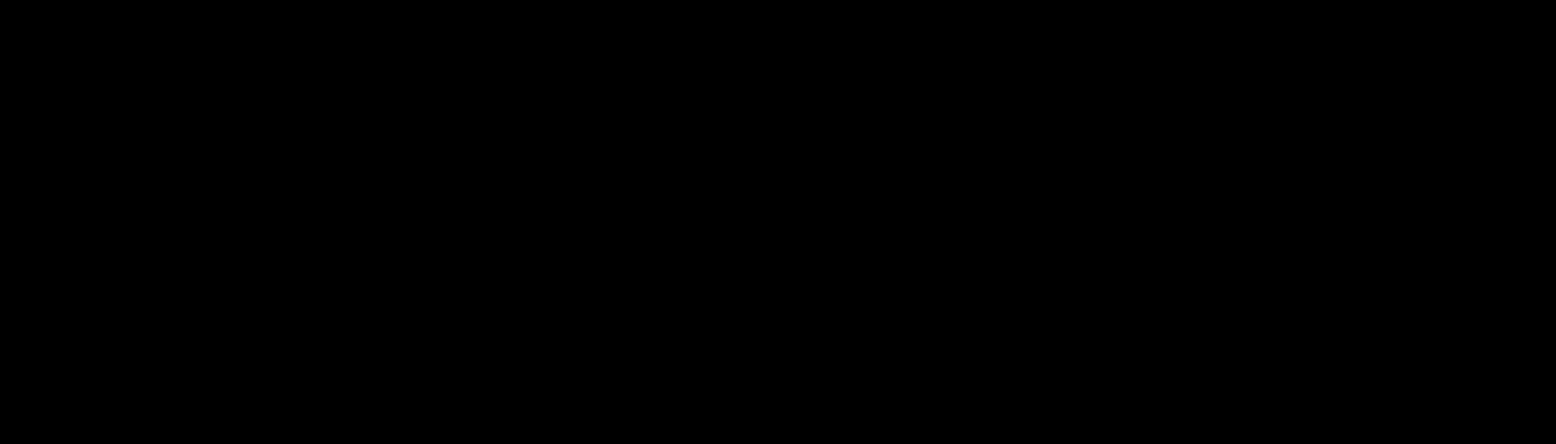

| | | | | | | | | |
|---------|-----------------|----|--------|-----|-----|------------|-----|------------|
| Code | Contact Name #4 | MI | Suffix | Age | Sex | Race | DOB | SSN |
| Address | | | | | | Home Phone | | Cell Phone |

| Property Information: | | | | | | | |
|------------------------------------|----------|---------|------|----------|------|-------|-------|
| Value of Stolen Property | Currency | Jewelry | Furs | Clothing | Auto | Misc. | Total |
| Value of Stolen Property Recovered | | | | | | | |

| Automobile Information: | | | | | | | | | |
|-------------------------|--------------|------|------|-----------|-------|-------|--------------|-------|-------------------|
| 1 | Vehicle Code | Year | Make | Body Type | Model | Color | Registration | State | VIN |
| | Veh. 1 | 06 | NIS | 4 DR | ALT | BN | U82HCP | NJ | 1N4AL11D36N429217 |
| | Veh. 2 | 01 | JEE | WAGON | GRA | SL | Z80HXB | NJ | 1J4GW48S91C500727 |
| 3 | | | | | | | | | |
| 4 | | | | | | | | | |

Narrative:
 [Redacted] responded to headquarters to report a MV crash that occurred in front of 1352 Teaneck Road.

| Officer of Record: | Date: | Other Reports Filed: | Reviewed By: |
|--------------------|----------|---|--------------|
| PO Lamon Meeks 305 | 07/30/18 | MVA <input checked="" type="checkbox"/> Arrest DV DWI DWIQ Tow SD CI TRO SHA Prop. Video UOF Prst Supp Juv Bias Pris | rharvey |

Page 1 of - Fatal **New Jersey Police Crash Investigation Report** Reportable Non-Reportable Change Report

1. Case Number: **18-035354** 10. Crash Occurred On: **Teaneck Road** 11. Speed Limit: **30**

2. Police Dept. of: **Teaneck** Code: **01** Road Name: **Teaneck Road** Dir: **---** 12. Route No. Suffix: **---** 13. Milepost: **---**

3. Station/Precinct: **01** At Intersection with N E S W of: **Garden St** 16. Speed Limit: **---**

4. Date of Crash: **07/30/18** 5. Day of Week: **M** 6. Time (use 2400 hrs.): **21:09** 7. Municipality Code: **0260** 8. Total Killed: **---** 9. Total Injured: **---** 19. To: **---** 17. Cross Road Name/Route No.: **---** NB EB SB WB

23. Veh. #: **1** 24. Policy No.: **939295367054** 25. NJ Ins. Code: **054** 53. Veh. #: **---** 54. Policy No.: **---** 55. NJ Ins. Code: **---**

26. Driver's First Name: **Carlos D Macon** 29. Sex: **M** 56. Driver's First Name: **---** 59. Sex: **---**

27. Number & Street: **52 Glenwood Dr North** 57. Number & Street: **---**

28. City: **Bergenfield, NJ 07621-3346** 58. City: **---**

30. Eyes: **2** DL Class: **---** Restrictions: **---** Endorsements: **---** 31. State: **NJ** 60. Eyes: **---** DL Class: **---** Restrictions: **---** Endorsements: **---** 61. State: **---**

32. Driver's License Number: **M0076 11064 09672** 33. DOB: **09/26/67** 34. Expires: **04/21** 62. Driver's License Number: **---** 63. DOB: **---** 64. Expires: **---**

35. Owner's First Name: **Carlos D Macon** 55. Owner's First Name: **Diandre D Mikell**

36. Number & Street: **52 Glenwood Dr North** 66. Number & Street: **12 Lafayette Pl**

37. City: **Bergenfield, NJ 07621-3346** 67. City: **Lodi, NJ 07644-2947**

38. Make: **nissan** 39. Model: **altima** 40. Color: **BN** 41. Year: **2006** 42. Plate No.: **U82HCP** 43. State: **NJ** 68. Make: **JEE** 69. Model: **GRA** 70. Color: **SL** 71. Year: **01** 72. Plate No.: **Z80HXB** 73. State: **NJ**

44. VIN: **1N4AL11D36N429217** 45. Expires: **10/18** 74. VIN: **1J4GW48S91C500727** 75. Expires: **05/19**

46. Vehicle Removed to: **---** 76. Vehicle Removed to: **---**

47. Authority: Owner Driver Police 77. Authority: Owner Driver Police

48. Alcohol Drug Test: Given: No Yes Refused Type: Breath Blood Urine Results: **0.00** % Pending 49. Hazardous Material: None On Board Spill Hazard Class: **---** Placard No.: **---**

78. Alcohol Drug Test: Given: No Yes Refused Type: Breath Blood Urine Results: **0.00** % Pending 79. Hazardous Material: None On Board Spill Hazard Class: **---** Placard No.: **---**

60. Carrier No.: USDOT MC/MX None 61. GVWR / GCWR (trucks & buses only): ≤ 10,000 lbs. 10,001 - 26,000 lbs. ≥ 26,001 lbs. 80. Carrier No.: USDOT MC/MX None 81. GVWR / GCWR (trucks & buses only): ≤ 10,000 lbs. 10,001 - 26,000 lbs. ≥ 26,001 lbs.

82. Motor Carrier or Government Entity: **---**

135. Damage to Other Property: Yes (if Yes, describe) No

Oper. 136. Charge: **---** 137. Summons No.: **---** Oper. 138. Charge: **---** 139. Summons No.: **---**

Oper. 140. Charge: **---** 141. Summons No.: **---** Oper. 142. Charge: **---** 143. Summons No.: **---**

| | 83 | 84 | 85 | 86 | 87 | 88 | 89 | 90 | 91 | 92 | 93 | 94 | 95 | Names & Addresses of Occupants If Deceased, Date & Time of Death |
|---|-----|-----|-----|-----|-----|-----|-----|-----|-----|-----|-----|-----|-----|---|
| A | 1 | 01 | 01 | --- | 50 | M | --- | --- | 04 | 04 | --- | --- | --- | Macon, Carlos-52 Glenwood Dr North, Bergenfield, NJ 07621-3346 |
| B | 1 | 02 | 01 | --- | 50 | M | --- | --- | 04 | 04 | --- | --- | --- | Macon, Carlos M - 52 Glenwood Dr. North, Bergenfield |
| C | --- | --- | --- | --- | --- | --- | --- | --- | --- | --- | --- | --- | --- | --- |
| D | --- | --- | --- | --- | --- | --- | --- | --- | --- | --- | --- | --- | --- | --- |

New Jersey Police
Crash Investigation Report

Case Number
18-035354

Page **2** of **-**

| | 83 | 84 | 85 | 86 | 87 | 88 | 89 | 90 | 91 | 92 | 93 | 94 | 95 | Names & Addresses of Occupants If Deceased, Date & Time of Death |
|---|-----|-----|-----|-----|-----|-----|-----|-----|-----|-----|-----|-----|-----|---|
| E | --- | --- | --- | --- | --- | --- | --- | --- | --- | --- | --- | --- | --- | |
| F | --- | --- | --- | --- | --- | --- | --- | --- | --- | --- | --- | --- | --- | |
| G | --- | --- | --- | --- | --- | --- | --- | --- | --- | --- | --- | --- | --- | |
| H | --- | --- | --- | --- | --- | --- | --- | --- | --- | --- | --- | --- | --- | |
| I | --- | --- | --- | --- | --- | --- | --- | --- | --- | --- | --- | --- | --- | |
| J | --- | --- | --- | --- | --- | --- | --- | --- | --- | --- | --- | --- | --- | |

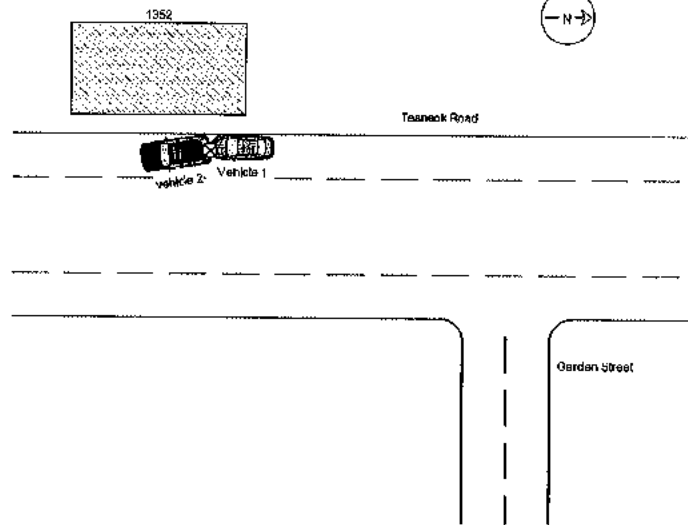

145. Crash Description/Narrative

Driver 1 stated that he was parked in front of 1352 Teaneck road with his son in the front passenger seat of the vehicle. He said vehicle 2 pulled up to parallel park in the spot in front of his vehicle. Vehicle 2 began to reverse into the spot striking vehicle 1. Vehicle 2 then pulled out of the spot and fled east on Garden Street. Vehicle 1 gave chase heading eastbound on Garden Street. Driver of vehicle 1 stated that approximately mid block vehicle 2 pulled a u-turn driving up onto the grass of a residence and began heading west on Garden Street. Vehicle 1 was unable to stay behind vehicle 2 as he lost sight of him when he got to the Intersection of Teaneck Road and Garden Street.

Driver 1 described vehicle 2 as a older model Jeep Cherokee, dark in color, driven by a black male, approximately 40-50 years of age. Vehicle might have sustained rear damage. 1352 Teaneck Road appears to have video surveillance, and might have caught the incident on video. Driver 1 was able to provide me with the plate number of NJ 780HXB for vehicle 2.

148. Officer's Signature

PO Lamon Meeks 305

147. Badge #

305

148. Reviewer

Sgt. Robert Harvey 286

Badge #

286

149. Case Status

Pending Complete



Teaneck Police Department

900 Teaneck Rd, Teaneck, NJ 07666

Phone: 201-837-2600 Fax: 201-837-1880 Mun. Code: 0260

Incident Report



Incident Details:

| | | | | | | | | | |
|-------------|---------------|---------------|---------------|---------------|-----------------------------------|---------------|---------------|-----|-----------|
| Case Number | Time Reported | Date Reported | Time Occurred | Date Occurred | Occurrence Between Date / Time of | Time Occurred | Date Occurred | 911 | Completed |
| 18-035887 | 14:55 | 08/02/18 | 14:55 | 08/02/18 | | 14:55 | 08/02/18 | | X |

Incident Type:

Investigation - Follow Up

Incident Location:

Street # Street Name Intersection / Cross Street of:
 1352 Teaneck Road Teaneck Road / Garden St
 Business / Common Location Name

Contact Information: Victim Suspect Complainant Witness Driver Arrest Recipient Missing Incident Other



| | | | | | | | | |
|---------|-----------------|----|--------|-----|-----|------------|------------|-----|
| Code | Contact Name #2 | MI | Suffix | Age | Sex | Race | DOB | SSN |
| Address | | | | | | Home Phone | Cell Phone | |
| Code | Contact Name #3 | MI | Suffix | Age | Sex | Race | DOB | SSN |
| Address | | | | | | Home Phone | Cell Phone | |
| Code | Contact Name #4 | MI | Suffix | Age | Sex | Race | DOB | SSN |
| Address | | | | | | Home Phone | Cell Phone | |

Property Information:

| | | | | | | | |
|------------------------------------|----------|---------|------|----------|------|-------|-------|
| Value of Stolen Property | Currency | Jewelry | Furs | Clothing | Auto | Misc. | Total |
| Value of Stolen Property Recovered | | | | | | | |

Automobile Information:

| 1 | Vehicle Code | Year | Make | Body Type | Model | Color | Registration | State | VIN |
|---|--------------|------|------|-----------|-------|-------|--------------|-------|-----|
| 2 | | | | | | | | | |
| 3 | | | | | | | | | |
| 4 | | | | | | | | | |

Narrative:

Secured evidence from [redacted] for report #18-035108.

Officer of Record: PO Patrick Haase 341 Date: 08/02/18 Other Reports Filed: MVA Arrest DV DWI DWIQ Tow SD CI TRO SHA Prop. Video UOF Prst Supp Juv Bias Pris Reviewed By: ttully



Teaneck Police Department

900 Teaneck Rd, Teaneck, NJ 07666

Phone: 201-837-2600 Fax: 201-837-1880 Mun. Code: 0260

Incident Report



Incident Details:

| | | | | | | | | | |
|-------------|---------------|---------------|---------------|---------------|-----------------------------------|---------------|---------------|-----|-----------|
| Case Number | Time Reported | Date Reported | Time Occurred | Date Occurred | Occurrence Between Date / Time of | Time Occurred | Date Occurred | 911 | Completed |
| 19-050499 | 22:04 | 09/14/19 | | | | | | | X |

Incident Type:

Incident Location:

| | | | |
|----------|---------------------------------|--------------|---------------------------------|
| MV Crash | Street # | Street Name | Intersection / Cross Street of: |
| | 1352 | Teaneck Road | Teaneck Road / Garden St |
| | Business / Common Location Name | | |

Contact Information: Victim Suspect Complainant Witness Driver Arrest Passenger Missing Involved Other

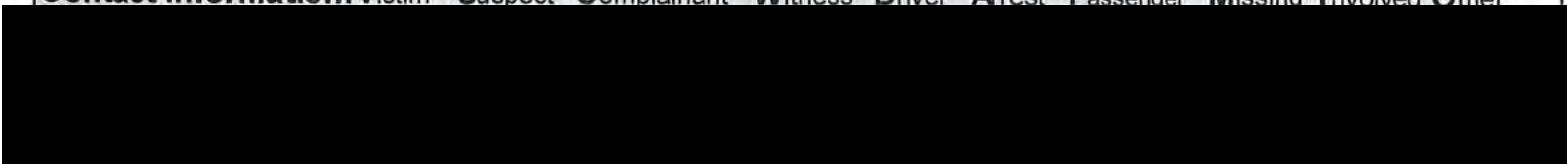

| | | | | | | | | |
|---------|-----------------|----|--------|-----|-----|------------|-----|------------|
| Code | Contact Name #2 | MI | Suffix | Age | Sex | Race | DOB | SSN |
| Address | | | | | | Home Phone | | Cell Phone |
| Code | Contact Name #3 | MI | Suffix | Age | Sex | Race | DOB | SSN |
| Address | | | | | | Home Phone | | Cell Phone |
| Code | Contact Name #4 | MI | Suffix | Age | Sex | Race | DOB | SSN |
| Address | | | | | | Home Phone | | Cell Phone |

Property Information:

| | | | | | | | |
|------------------------------------|----------|---------|------|----------|------|-------|-------|
| Value of Stolen Property | Currency | Jewelry | Furs | Clothing | Auto | Misc. | Total |
| Value of Stolen Property Recovered | | | | | | | |

Automobile Information:

| | | | | | | | | | |
|---|--------------|------|------|-----------|-------|-------|--------------|-------|-------------------|
| 1 | Vehicle Code | Year | Make | Body Type | Model | Color | Registration | State | VIN |
| | Veh. 2 | 05 | TOY | WAGON | SIE | RD | A91BSX | NJ | 5TDZA22CX5S283325 |
| 2 | | | | | | | | | |
| 3 | | | | | | | | | |
| 4 | | | | | | | | | |

Narrative:

Officer of Record: Date: Other Reports Filed: Reviewed By:

| | | | | | | | | | |
|----------------------------------|--|-------|-------|------|------|------|-----|------|---------|
| PO Victoria Kellman 345 09/14/19 | MVA <input checked="" type="checkbox"/> Arrest | DV | DWI | DWIQ | Tow | SD | CI | TRO | rharvey |
| | SHA | Prop. | Video | UOF | Prst | Supp | Juv | Bias | |

| | | | | | | | | | | | |
|---|---|--|--|--|--|---|-------------------------------------|--|-------------------------|--|-------------|
| 96 05 | 1. Case Number 19-050499 | | | | | | | | | | 118a 00 |
| 97 01 | 10. Crash Occurred On: Teaneck Road | | | | | | | | | | 118b 00 |
| 98 07 | 2. Police Dept. of Teaneck Code 01 | | | | | 11. Speed Limit 30 | | | | | 119a 25 |
| 99 07 | 3. Station/Precinct | | | | | 12. Route No. Suffix 13. Milepost | | | | | 119b --- |
| 100a 01 | 4. Date of Crash mm dd yy 09 14 19 | | 6. Day of Week Su M Tu W Th F Sa Sa | | 6. Time (use 2400 hrs.) mm ss 22 04 | | 7. Municipality Code 0260 | | 9. Total Killed Injured | | 120a 00 |
| 100b 04 | 23. Veh. # 24. Policy No. | | | | | 25. NJ Ins. Code | | | | | 120b 00 |
| 101 02 | 26. Driver's First Name Initial Last Name | | | | | 29. Sex | | | | | 121a 01 |
| 102 02 | 27. Number & Street | | | | | 57. Number & Street | | | | | 121b --- |
| 103 02 | 28. City State Zip | | | | | 58. City State Zip | | | | | 122 00 |
| 104 02 | 30. Eyes DL Class Restrictions Endorsements 31. State | | | | | 60. Eyes DL Class Restrictions Endorsements 61. State | | | | | 123 10 |
| 105 06 | 32. Driver's License Number | | | | | 33. DOB mm dd yy | | | | | 124 11 |
| 106 00 | 35. Owner's First Name Initial Last Name | | | | | 65. Owner's First Name Initial Last Name | | | | | 126 11 |
| 107 00 | 36. Number & Street | | | | | 68. Number & Street | | | | | 126a 28 |
| 108 01 | 37. City State Zip | | | | | 67. City State Zip | | | | | 126b --- |
| 109 00 | 39. Make 39. Model 40. Color 41. Year 42. Plate No. 43. State | | | | | 69. Make 69. Model 70. Color 71. Year 72. Plate No. 73. State | | | | | 126c --- |
| 110 01 | 44. VIN 45. Expires | | | | | 74. VIN 75. Expires | | | | | 126d --- |
| 111 00 | 46. Vehicle Removed to: | | | | | 76. Vehicle Removed to: | | | | | 126e 28 |
| 112 00 | 47. Authority | | | | | 77. Authority | | | | | 127a 26 |
| 113 00 | 48. Alcohol Drug Test | | | | | 78. Alcohol Drug Test | | | | | 127b --- |
| 114 01 | 49. Hazardous Material | | | | | 79. Hazardous Material | | | | | 127c --- |
| 115 01 | 60. Carrier No. | | | | | 80. Carrier No. | | | | | 127d 26 |
| 116 01 | 62. Motor Carrier or Government Entity | | | | | 82. Motor Carrier or Government Entity | | | | | 127e 26 |
| 135. Damage to Other Property <input type="checkbox"/> Yes (if Yes, describe) <input type="checkbox"/> No | | | | | | | | | | | 128 01 |
| Oper. 136. Charge 137. Summons No. Oper. 138. Charge 139. Summons No. | | | | | | | | | | | 129 00 |
| Oper. 140. Charge 141. Summons No. Oper. 142. Charge 143. Summons No. | | | | | | | | | | | 130 03 |

| | 83 | 84 | 85 | 86 | 87 | 88 | 89 | 90 | 91 | 92 | 93 | 94 | 95 | Names & Addresses of Occupants If Deceased, Date & Time of Death |
|---|-----|-----|-----|-----|-----|-----|-----|-----|-----|-----|-----|-----|-----|---|
| A | 1 | 00 | --- | 00 | U | 00 | 00 | 00 | 00 | 00 | 00 | --- | --- | |
| B | --- | --- | --- | --- | --- | --- | --- | --- | --- | --- | --- | --- | --- | |
| C | --- | --- | --- | --- | --- | --- | --- | --- | --- | --- | --- | --- | --- | |
| D | --- | --- | --- | --- | --- | --- | --- | --- | --- | --- | --- | --- | --- | |

New Jersey Police
Crash Investigation Report

Case Number
19-050499

Page 2 of 2

| | 83 | 84 | 85 | 86 | 87 | 88 | 89 | 90 | 91 | 92 | 93 | 94 | 95 | Names & Addresses of Occupants # Deceased, Date & Time of Death |
|---|-----|-----|-----|-----|-----|-----|-----|-----|-----|-----|-----|-----|-----|--|
| E | --- | --- | --- | --- | --- | --- | --- | --- | --- | --- | --- | --- | --- | |
| F | --- | --- | --- | --- | --- | --- | --- | --- | --- | --- | --- | --- | --- | |
| G | --- | --- | --- | --- | --- | --- | --- | --- | --- | --- | --- | --- | --- | |
| H | --- | --- | --- | --- | --- | --- | --- | --- | --- | --- | --- | --- | --- | |
| I | --- | --- | --- | --- | --- | --- | --- | --- | --- | --- | --- | --- | --- | |
| J | --- | --- | --- | --- | --- | --- | --- | --- | --- | --- | --- | --- | --- | |

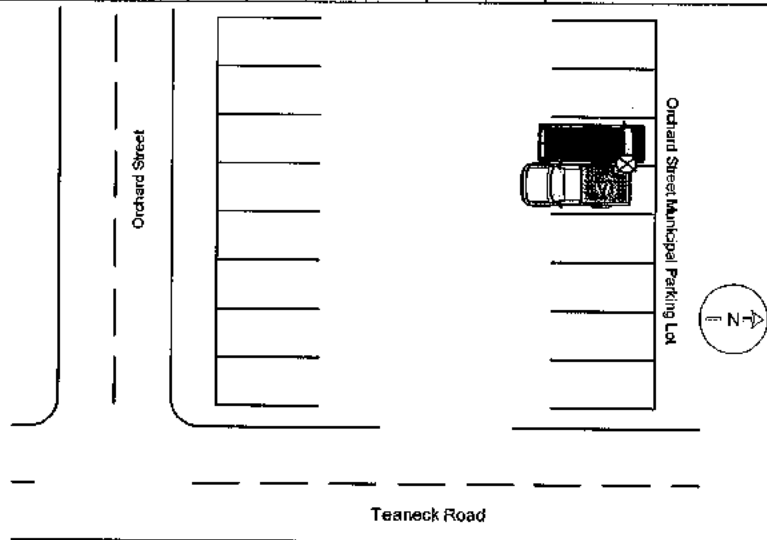

145. Crash Description/Narrative

The owner of vehicle #2 reported that at approximately 9:30 PM, he parked his vehicle inside the Orchard Street Municipal Parking Lot in the six spot northwest of Teaneck Road. He advised me that he went to get food from Reggae Kitchen. He did not return back to his vehicle until 10:00 PM. As he was walking back to his vehicle, he observed that half of his windshield was cracked and the front passenger's side window to the rear passenger's side window.

With further investigation, I observed that there was multiple pieces of wooden material inside his windshield and the rear passenger door from the crash. I determined that it could possibly be a pickup with a wooden flat bed that struck his vehicle in the attempt to get into a spot, inside of vehicle #2.

| | | | | |
|---|---------------------|---|----------------|--|
| 146. Officer's Signature PO Victoria Kellman 345 | 147. Badge # 345 | 148. Reviewer Sgt. Robert Harvey 286 | Badge # 286 | 149. Case Status <input type="checkbox"/> Pending <input type="checkbox"/> Complete |
|---|---------------------|---|----------------|--|



Teaneck Police Department

900 Teaneck Rd, Teaneck, NJ 07666

Phone: 201-837-2600 Fax: 201-837-1880 Mun. Code: 0260

Incident Report



Incident Details:

| | | | | | | | | | |
|-------------|---------------|---------------|---------------|---------------|-----------------------------------|---------------|---------------|-----|-----------|
| Case Number | Time Reported | Date Reported | Time Occurred | Date Occurred | Occurrence Between Date / Time of | Time Occurred | Date Occurred | 911 | Completed |
| 19-065452 | 10:58 | 11/30/19 | 10:58 | 11/30/19 | | | | | X |

Incident Type:

Illegal Dumping

Incident Location:

Street # Street Name Intersection / Cross Street of:
 1352 Teaneck Road Teaneck Road / Garden St
 Business / Common Location Name

Contact Information: Victim Suspect Complainant Witness Driver Arrest Passenger Missing Involved Other

| Code | Contact Name #1 | MI | Suffix | Age | Sex | Race | DOB | SSN |
|---------|-----------------|----|--------|-----|-----|------------|-----|------------|
| | | | | | | | | |
| Address | | | | | | Home Phone | | Cell Phone |
| | | | | | | | | |
| Address | | | | | | Home Phone | | Cell Phone |
| | | | | | | | | |
| Address | | | | | | Home Phone | | Cell Phone |
| | | | | | | | | |
| Address | | | | | | Home Phone | | Cell Phone |

Property Information:

| | | | | | | | |
|------------------------------------|----------|---------|------|----------|------|-------|-------|
| Value of Stolen Property | Currency | Jewelry | Furs | Clothing | Auto | Misc. | Total |
| Value of Stolen Property Recovered | | | | | | | |

Automobile Information:

| 1 | Vehicle Code | Year | Make | Body Type | Model | Color | Registration | State | VIN |
|---|--------------|------|------|-----------|-------|-------|--------------|-------|-----|
| 2 | | | | | | | | | |
| 3 | | | | | | | | | |
| 4 | | | | | | | | | |

Narrative:

On Saturday, November 30, 2019, at 10:58 A.M., I responded to the municipal parking lot on Teaneck Rd between Garden St & Orchard St. on a report of illegal dumping.

Upon arrival, I discovered a Champion Global Power Equipment Inverter 2000 watt generator and nine garbage bags left on the north side of the municipal parking lot. I couldn't locate information on who dumped the garbage. At headquarters, a Problem Report Form was e-mailed to the Department of Public Works to remove the items.

Officer Steven Batista #325

Officer of Record: Date: Other Reports Filed: Reviewed By:

| | | | |
|-----------------------|----------|---|----------|
| PO Steven Batista 325 | 11/30/19 | MVA Arrest DV DWI DWIQ Tow SD CI TRO | pforrest |
| | | SHA Prop. Video UOF Prst Supp Juv Bias Pris | |



Teaneck Police Department

900 Teaneck Rd, Teaneck, NJ 07666

Phone: 201-837-2600 Fax: 201-837-1880 Mun. Code: 0260

Incident Report



Incident Details:

| Case Number | Time Reported | Date Reported | Time Occurred | Date Occurred | Occurrence Between Date / Time of | Time Occurred | Date Occurred | 911 | Completed |
|-------------|---------------|---------------|---------------|---------------|-----------------------------------|---------------|---------------|-----|-----------|
| 19-067254 | 12:56 | 12/10/19 | 12:56 | 12/10/19 | | | | | X |

Incident Type:

Shoplifting 2C:20-11

Incident Location:

| | | |
|---------------------------------|--------------|---------------------------------|
| Street # | Street Name | Intersection / Cross Street of: |
| 1352 | Teaneck Road | Teaneck Road / Garden St |
| Business / Common Location Name | | |

Contact Information: Victim Suspect Complainant Witness Driver Arrest Passenger Missing Involved Other

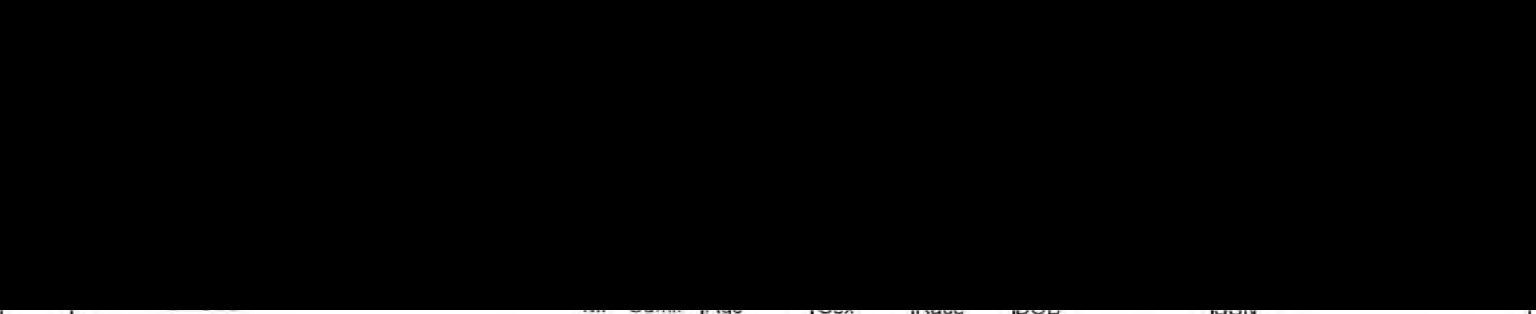

| | | |
|---|------------|------------|
| Address | Home Phone | Cell Phone |
| Code Contact Name #4 MI Suffix Age Sex Race DOB SSN | | |
| Address | Home Phone | Cell Phone |

Property Information:

| Value of Stolen Property | Currency | Jewelry | Furs | Clothing | Auto | Misc. | Total |
|------------------------------------|----------|---------|------|----------|------|--------|--------|
| | | | | | | \$2.00 | \$2.00 |
| Value of Stolen Property Recovered | | | | | | | |

Automobile Information:

| 1 | Vehicle Code | Year | Make | Body Type | Model | Color | Registration | State | VIN |
|---|--------------|------|------|-----------|-------|-------|--------------|-------|-----|
| 2 | | | | | | | | | |
| 3 | | | | | | | | | |
| 4 | | | | | | | | | |

Narrative:

On Tuesday, December 10, 2019, P.O. Z. Reed and I responded to 1352 Teaneck Road, H and R Liquor on a report of a activated panic alarm.

Upon my arrival, I met with the owner [REDACTED] who stated that a known customer entered the store, removed a can of beer from the cooler and walked up to the counter to pay for it. He stated that he was seated by the lottery machine and when he walked over to the counter, he observed that the actor had only placed a quarter on the counter before running out of the store. He stated that he ran out of the store after the actor and observed him riding his bike east on Beveridge Street. He described that actor as a light skinned black male with a mustache, slim build, tall and in

| Officer of Record: | Date: | Other Reports Filed: | Reviewed By: |
|--------------------|----------|---|--------------|
| PO Percy West 299 | 12/10/19 | MVA Arrest DV DWI DWIQ Tow SD CI TRO SHA Prop. Video UOF Prst Supp Juv Bias Pris | pforrest |



Teaneck Police Department

900 Teaneck Rd, Teaneck, NJ 07666

Phone: 201-837-2600 Fax: 201-837-1880 Mun. Code: 0260

Incident Report



Narrative Continued (Page 2)

Case Number

19-067254

his 60's.

Upon reviewing the security video, I was able to identify the actor as [REDACTED] from previous incidents. [REDACTED] stated that he did not want to sign a complaint against [REDACTED] but wanted him to be informed that he is no longer welcome in the store. He stated the total cost of the beer was \$1.25.

P.O. Percy West #299

Officer of Record:

Date:

PO Percy West 299

12/10/19



Teaneck Police Department

900 Teaneck Rd, Teaneck, NJ 07666

Phone: 201-837-2600 Fax: 201-837-1880 Mun. Code: 0260

Incident Report



| Incident Details: | | | | | | | | | |
|-------------------|---------------|---------------|---------------|---------------|-----------------------------------|---------------|---------------|-----|-----------|
| Case Number | Time Reported | Date Reported | Time Occurred | Date Occurred | Occurrence Between Date / Time of | Time Occurred | Date Occurred | 911 | Completed |
| 21-016241 | 14:14 | 03/31/21 | 14:14 | 03/31/21 | | | | | X |

| Incident Type: | | Incident Location: | | |
|---|--|---------------------------------|--------------|---------------------------------|
| Shoplifting 2C:20-11 Alarm - Burglar | | Street # | Street Name | Intersection / Cross Street of: |
| | | 1352 | Teaneck Road | Teaneck Road / Garden St |
| | | Business / Common Location Name | | |

Contact Information: Victim Suspect Complainant Witness Driver Arrest Passenger Missing Involved Other

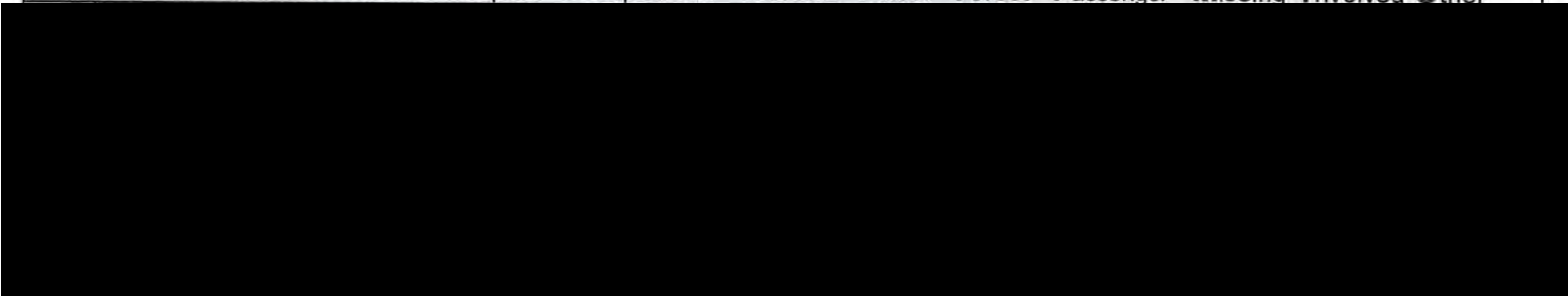

| | | | | | | | | |
|---------|-----------------|----|--------|-----|-----|------------|------------|-----|
| Code | Contact Name #3 | MI | Suffix | Age | Sex | Race | DOB | SSN |
| Address | | | | | | Home Phone | Cell Phone | |
| Code | Contact Name #4 | MI | Suffix | Age | Sex | Race | DOB | SSN |
| Address | | | | | | Home Phone | Cell Phone | |

| Property Information: | | | | | | | |
|------------------------------------|----------|---------|------|----------|------|----------|----------|
| Value of Stolen Property | Currency | Jewelry | Furs | Clothing | Auto | Misc. | Total |
| | | | | | | \$198.00 | \$198.00 |
| Value of Stolen Property Recovered | | | | | | | |

| Automobile Information: | | | | | | | | | |
|-------------------------|--------------|------|------|-----------|-------|-------|--------------|-------|-----|
| 1 | Vehicle Code | Year | Make | Body Type | Model | Color | Registration | State | VIN |
| 2 | | | | | | | | | |
| 3 | | | | | | | | | |
| 4 | | | | | | | | | |

Narrative:
 On Wednesday, March 31, 2021, at approximately 2:14 PM, Officer Rafael Vallejos #362 and I responded to H&R Liquors, located at 1352 Teaneck Road, on the report of shoplifting, which had just taken place. I responded to the scene in marked patrol vehicle #9 with emergency lights and audible siren activated.
 Upon arrival, I spoke with the proprietor of the business [REDACTED], who reported that the actor, described as tall, thin, black male, had stolen two bottles of alcoholic beverage, namely, Clase Azul Reposado tequila, valued at \$159.99 and Don Julio Blanco tequila, valued at \$24.99 (total proceeds + tax = 197.23); before running from the store, getting into a parked vehicle, and fleeing southbound on

| Officer of Record: | Date: | Other Reports Filed: | Reviewed By: |
|---------------------|----------|---|--------------|
| PO Kevin Florio 349 | 03/31/21 | MVA Arrest DV DWI DWIQ Tow SD CI TRO SHA Prop. Video UOF Prst Supp 1 Juv Bias Pris | cantinori |



Teaneck Police Department

900 Teaneck Rd, Teaneck, NJ 07666

Phone: 201-837-2600 Fax: 201-837-1880 Mun. Code: 0260

Incident Report



Narrative Continued (Page 2)

Case Number

21-016241

Teaneck Road.

[REDACTED] was initially unable to provide a more detailed description of the actor. He told us that the actor fled in a black sedan, but was unable to discern the make/model of the vehicle, or its registration, only telling us that he believed it displayed a New Jersey temporary registration.

Officer Vallejos began circulating the area in an attempt to locate a vehicle matching that description, with negative results.

With Mr. Blimpie's permission, I began to review the store's surveillance footage. The footage depicted the actor, a tall black male, wearing a white polo style t-shirt, black sweat pants, silver and white Nike sneakers, a green skull cap and a blue face covering, enter the store at approximately 2:09 PM. Estimating from the footage, he appeared to be aged in his late 20's or early 30's. The actor meanders around the business while [REDACTED] attends to another customer. He does not attempt to conceal any merchandise at this point. Upon gaining [REDACTED] attention, he requests a highly priced bottle of tequila (Clase Azul Reposado), which [REDACTED] is required to retrieve from a back room. The actor is seen grabbing another bottle of tequila (Don Julio). He places that bottle on the counter and waits for [REDACTED] to return.

When [REDACTED] emerges from the back room with the other bottle of tequila, the actor requests one more bottle, which is located on shelf behind the counter, requiring [REDACTED] to turn his back to the actor to retrieve. As he turns his back, the actor is clearly seen grabbing both bottles of tequila from the counter and immediately thereafter hurriedly exiting the store. He does not use force of any kind during the commission of the theft. Another camera located on the exterior of the business captured the actor running southbound on the western sidewalk of Teaneck Road, before entering a black sedan which was parked just out of view of [REDACTED] camera frame. The actor flees from the business at 2:12:38 PM.

Multiple pictures of the actor, taken from the surveillance footage, can be found attached.

On Thursday, April 1, 2021, I returned to H&R liquors for the purpose of reviewing the surveillance footage from Blimpie, located adjacent to [REDACTED]'s business, at 1348 Teaneck Road. Blimpie is owned by Mr. [REDACTED] so [REDACTED] I reviewed the footage of the prior day's events. At 2:08:26 PM, the unidentified actor can be seen parking his car, which appears to be a newer model Ford Focus, color black, on the western side of Teaneck Road, just south of the business, near the entrance to the Orchard Street municipal parking lot. I was able to discern a partial registration for the vehicle, which appears to be either 64515R or 54515R, both of which are missing one digit. Pictures of the actor vehicle are also found attached.

BWC

Officer of Record:

Date:

PO Kevin Florio 349

03/31/21



Teaneck Police Department

900 Teaneck Rd, Teaneck, NJ 07666

Phone: 201-837-2600 Fax: 201-837-1880 Mun. Code: 0260

Incident Report



Incident Details:

| | | | | | | | | | |
|-------------|---------------|---------------|---------------|---------------|-----------------------------------|---------------|---------------|-----|-----------|
| Case Number | Time Reported | Date Reported | Time Occurred | Date Occurred | Occurrence Between Date / Time of | Time Occurred | Date Occurred | 911 | Completed |
| 22-031044 | 12:57 | 06/01/22 | 12:57 | 06/01/22 | | | | X | X |

Incident Type:

MV Crash

Incident Location:

| | | |
|---------------------------------|--------------|---------------------------------|
| Street # | Street Name | Intersection / Cross Street of: |
| 1344 | Teaneck Road | Teaneck Road / Orchard St |
| Business / Common Location Name | | |

Contact Information: Victim Suspect Complainant Witness Driver Arrest Passenger Missing Involved Other

| Code | Contact Name #1 | MI | Suffix | Age | Sex | Race | DOB | SSN |
|------|-----------------|----|--------|-----|-----|------|-----|-----|
|------|-----------------|----|--------|-----|-----|------|-----|-----|

| | | | | | | | | |
|------------|--|--|--|--|--|--|------------|------------|
| [Redacted] | | | | | | | Home Phone | Cell Phone |
| [Redacted] | | | | | | | [Redacted] | [Redacted] |

| Code | Contact Name #2 | MI | Suffix | Age | Sex | Race | DOB | SSN |
|------|-----------------|----|--------|-----|-----|------|-----|-----|
|------|-----------------|----|--------|-----|-----|------|-----|-----|

| | | | | | | | | |
|------------|--|--|--|--|--|--|------------|------------|
| [Redacted] | | | | | | | Home Phone | Cell Phone |
| [Redacted] | | | | | | | [Redacted] | [Redacted] |

| Code | Contact Name #3 | MI | Suffix | Age | Sex | Race | DOB | SSN |
|------|-----------------|----|--------|-----|-----|------|-----|-----|
|------|-----------------|----|--------|-----|-----|------|-----|-----|

| | | | | | | | | |
|------------|--|--|--|--|--|--|------------|------------|
| [Redacted] | | | | | | | Home Phone | Cell Phone |
| [Redacted] | | | | | | | [Redacted] | [Redacted] |

| Code | Contact Name #4 | MI | Suffix | Age | Sex | Race | DOB | SSN |
|------|-----------------|----|--------|-----|-----|------|-----|-----|
|------|-----------------|----|--------|-----|-----|------|-----|-----|

| | | | | | | | | |
|------------|--|--|--|--|--|--|------------|------------|
| [Redacted] | | | | | | | Home Phone | Cell Phone |
| [Redacted] | | | | | | | [Redacted] | [Redacted] |

Property Information:

| Value of Stolen Property | Currency | Jewelry | Furs | Clothing | Auto | Misc. | Total |
|------------------------------------|----------|---------|------|----------|------|-------|-------|
| | | | | | | | |
| Value of Stolen Property Recovered | | | | | | | |

Automobile Information:

| 1 | Vehicle Code | Year | Make | Body Type | Model | Color | Registration | State | VIN |
|---|--------------|------|------|-----------|-------|-------|--------------|-------|-------------------|
| | Veh. 1 | 07 | MB | WAGON | R35 | WT | P44NYA | NJ | 4JGCB65EX7A047762 |
| | Veh. 2 | 07 | CAD | WAGON | ESC | BK | UW73LU | NJ | 1GYFK66847R426911 |
| 3 | | | | | | | | | |
| 4 | | | | | | | | | |

Narrative:

Refer to NJTR-1.

Officer of Record: Date: Other Reports Filed: Reviewed By:

| | | | | | | | | | | |
|--------------------|----------|--|-------|-------|------|------|------|-----|------|----------|
| PO Kevin Gibbs 363 | 06/01/22 | MVA <input checked="" type="checkbox"/> Arrest | DV | DWI | DWIQ | Tow | SD | CI | TRO | jgarland |
| | | SHA | Prop. | Video | UOF | Prst | Supp | Juv | Bias | |

Page 1 of 2 Fatal New Jersey Police Crash Investigation Report Reportable Non-Reportable Change Report

1. Case Number: 22-031044
 2. Police Dept. of: Teaneck
 3. Station/Precinct: 01
 10. Crash Occurred On: 1344 Teaneck Road
 11. Speed Limit: 10
 12. Route No., Suffix, 13. Milepost: ---
 14. At Intersection with: Feet Miles
 15. Direction: N E S W
 16. Direction of: ---
 17. Cross Road Name/Route No.: ---
 18. Ramp: To: From: ---
 19. To: ---
 20. Route Name/Route No.: ---
 21. Latitude: ---
 22. Longitude: ---
 23. Veh. # 24. Policy No.: 1 135 1915-D15-30
 25. NJ Ins. Code: 962
 26. Driver's First Name: Qasim Ali
 27. Number & Street: 389 Knickerbocker Rd
 28. City: Englewood, NJ 07631-1428
 29. Sex: M
 30. Eyes: 2
 31. State: NJ
 32. Driver's License Number: A5335 63500 02572
 33. DOB: 02/01/57
 34. Expires: 02/23
 35. Owner's First Name: Qasim Ali
 36. Number & Street: 389 Knickerbocker Rd
 37. City: Englewood, NJ 07631-1428
 38. Make: MB
 39. Model: R35
 40. Color: WT
 41. Year: 07
 42. Plate No.: P44NYA
 43. State: NJ
 44. VIN: 4JGCB65EX7A047762
 45. Expires: 07/22
 46. Vehicle Removed to: Driven Towed Disabled Towed Disabled & Impounded
 47. Authority: Owner Driver Police
 48. Alcohol Drug Test: Given: No Yes Refused
 Type: Breath Blood Urine
 Results: 0.00% Pending
 49. Hazardous Material: None On Board Spill
 Type: Breath Blood Urine
 Results: 0.00% Pending
 50. Carrier No.: USDOT None
 51. GVWR / GCWR (trucks & buses only): ≤ 10,000 lbs. 10,001 - 26,000 lbs. ≥ 26,001 lbs.
 52. Motor Carrier or Government Entity: Yes No
 53. Damage to Other Property: Yes (if Yes, describe) No
 54. Veh. # 55. Policy No.: 2 110 2290-F29-30C
 56. Driver's First Name: Rashad Z Robinson
 57. Number & Street: 1266 Teaneck Rd Apt 9a
 58. City: Teaneck, NJ 07666-4947
 59. Sex: M
 60. Eyes: 2
 61. State: NJ
 62. Driver's License Number: R6022 64289 02802
 63. DOB: 02/28/80
 64. Expires: 02/25
 65. Owner's First Name: Rashad Z Robinson
 66. Number & Street: 1266 Teaneck Rd Apt 9a
 67. City: Teaneck, NJ 07666-4947
 68. Make: CAD
 69. Model: ESC
 70. Color: BK
 71. Year: 07
 72. Plate No.: UW73LU
 73. State: NJ
 74. VIN: 1GYFK66847R426911
 75. Expires: 09/22
 76. Vehicle Removed to: Driven Towed Disabled Towed Disabled & Impounded
 77. Authority: Owner Driver Police
 78. Alcohol Drug Test: Given: No Yes Refused
 Type: Breath Blood Urine
 Results: 0.00% Pending
 79. Hazardous Material: None On Board Spill
 Type: Breath Blood Urine
 Results: 0.00% Pending
 80. Carrier No.: USDOT None
 81. GVWR / GCWR (trucks & buses only): ≤ 10,000 lbs. 10,001 - 26,000 lbs. ≥ 26,001 lbs.
 82. Motor Carrier or Government Entity: Yes No
 136. Charge: ---
 137. Summons No.: ---
 138. Charge: ---
 139. Summons No.: ---
 140. Charge: ---
 141. Summons No.: ---
 142. Charge: ---
 143. Summons No.: ---

| | | Names & Addresses of Occupants If Deceased, Date & Time of Death | | | | | | | | | | | | |
|---|------|---|------|------|------|------|------|------|------|------|------|------|------|---|
| | | 83 | 84 | 85 | 86 | 87 | 88 | 89 | 90 | 91 | 92 | 93 | 94 | 95 |
| A | 1 | 01 | 01 | 05 | 65 | M | ---- | ---- | 1 | 11 | 04 | ---- | ---- | Ali, Qasim-389 Knickerbocker Rd, Englewood, NJ 07631-1428 |
| B | 1 | 03 | 01 | 05 | 48 | F | --- | --- | 1 | 11 | 04 | ---- | ---- | Leslie, Lisa-92 Oak Street, Teaneck, NJ 07666 |
| C | 2 | 01 | 01 | 05 | 42 | M | ---- | ---- | 1 | 11 | 04 | ---- | ---- | Robinson, Rashad-1266 Teaneck Rd Apt 9a, Teaneck, NJ 07666-4947 |
| D | ---- | ---- | ---- | ---- | ---- | ---- | ---- | ---- | ---- | ---- | ---- | ---- | ---- | ---- |

| | 83 | 84 | 85 | 86 | 87 | 88 | 89 | 90 | 91 | 92 | 93 | 94 | 95 | Names & Addresses of Occupants If Deceased, Date & Time of Death |
|---|-----|-----|-----|-----|-----|-----|-----|-----|-----|-----|-----|-----|-----|---|
| | E | --- | --- | --- | --- | --- | --- | --- | --- | --- | --- | --- | --- | --- |
| F | --- | --- | --- | --- | --- | --- | --- | --- | --- | --- | --- | --- | --- | ----- |
| G | --- | --- | --- | --- | --- | --- | --- | --- | --- | --- | --- | --- | --- | ----- |
| H | --- | --- | --- | --- | --- | --- | --- | --- | --- | --- | --- | --- | --- | ----- |
| I | --- | --- | --- | --- | --- | --- | --- | --- | --- | --- | --- | --- | --- | ----- |
| J | --- | --- | --- | --- | --- | --- | --- | --- | --- | --- | --- | --- | --- | ----- |

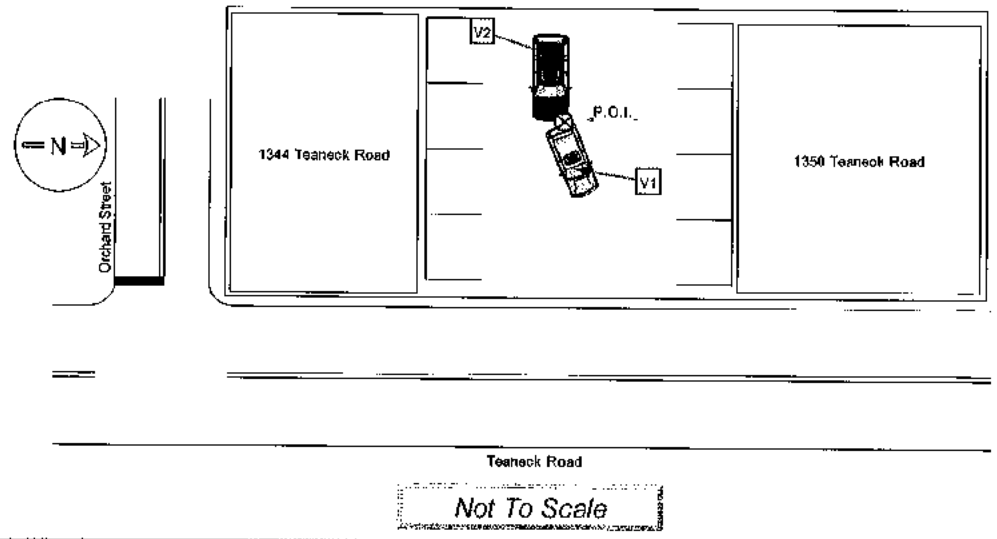

145. Crash Description/Narrative

Driver of vehicle #1 reported he was backing out of a designated parking space in the parking lot of 1344 Teaneck Road. He further reported he did not observe any vehicles behind him and continued to back up. At this time, he collided into the front of vehicle #2

Driver of vehicle #2 reported he was driving east in the parking lot of 1344 Teaneck Road, when he observed vehicle #1 backing. He further reported after his observations, he stopped his vehicle and honked the horn several times, to alert driver of vehicle #1. At this time, driver of vehicle #2 reported vehicle #1 collided into the front of his vehicle.

| | | | | |
|---|----------------------------|--|-----------------------|---|
| 146. Officer's Signature PO Kevin Gibbs 363 | 147. Badge # 363 | 148. Reviewer Lt. John Garland 272 | Badge # 272 | 149. Case Status <input type="checkbox"/> Pending <input checked="" type="checkbox"/> Complete |
|---|----------------------------|--|-----------------------|---|



Teaneck Police Department

900 Teaneck Rd, Teaneck, NJ 07666

Phone: 201-837-2600 Fax: 201-837-1880 Mun. Code: 0260



Incident Report

| Incident Details: | | | Incident Location: | Disposition |
|-------------------|-------|----------|---------------------------------|------------------|
| Case Number | Time | Date | Address | Disposition |
| PD-17-035573 | 16:24 | 09/26/17 | 1340 TEANECK ROAD, TEANECK TWP, | Report Completed |

Incident Type:

Lost Property / Articles

Narrative

Officer

Approving Officer

rglor

rmehn

On Tuesday September 26 2017 [REDACTED] the owner of Leasco Automotive Sales and Leasing Inc. 1340 Teaneck Road responded to police headquarters on a lost property report. Mr. [REDACTED] reported that he sent in the mail two license plates bearing New Jersey registration H39JAC and the registration card for the same [REDACTED] Teaneck New Jersey but it was supposed to be sent to [REDACTED] He reported that the license plates and the registration were for a 2017 Nissan Sentra bought by [REDACTED] He reported that the license plates and vehicle registration were never returned back to him and he does not know where they are. [REDACTED] reported that he sent the above mentioned items to [REDACTED] Teaneck New Jersey because that was the address on [REDACTED] drivers license and he was unaware that he had moved to Bergenfield New Jersey. P.O. Robert Gloria 300



Teaneck Police Department

900 Teaneck Rd, Teaneck, NJ 07666

Phone: 201-837-2600 Fax: 201-837-1880 Mun. Code: 0260

Incident Report



Incident Details:

| | | | | | | | | | |
|-------------|---------------|---------------|---------------|---------------|-----------------------------------|---------------|---------------|-----|-----------|
| Case Number | Time Reported | Date Reported | Time Occurred | Date Occurred | Occurrence Between Date / Time of | Time Occurred | Date Occurred | 911 | Completed |
| 22-021785 | 12:30 | 04/19/22 | 12:30 | 04/19/22 | | | | X | X |

Incident Type:

Simple Assault 2C:12-1a

Incident Location:

Street # Street Name Intersection / Cross Street of:
 1340 Teaneck Road Teaneck Road / Orchard St
 Business / Common Location Name

Contact Information: Victim Suspect Complainant Witness Driver Arrest Passenger Missing Involved Other

| Code | Contact Name #1 | MI | Suffix | Age | Sex | Race | DOB | SSN |
|------------|-----------------|----|--------|-----|-----|------------|------------|-----|
| I | [REDACTED] | | | | | | | |
| Address | | | | | | Home Phone | Cell Phone | |
| [REDACTED] | | | | | | | [REDACTED] | |
| Code | Contact Name #2 | MI | Suffix | Age | Sex | Race | DOB | SSN |
| | [REDACTED] | | | | | | | |
| Address | | | | | | Home Phone | Cell Phone | |
| [REDACTED] | | | | | | | [REDACTED] | |
| Code | Contact Name #3 | MI | Suffix | Age | Sex | Race | DOB | SSN |
| | [REDACTED] | | | | | | | |
| Address | | | | | | Home Phone | Cell Phone | |
| [REDACTED] | | | | | | | [REDACTED] | |
| Code | Contact Name #4 | MI | Suffix | Age | Sex | Race | DOB | SSN |
| | [REDACTED] | | | | F | | | |
| Address | | | | | | Home Phone | Cell Phone | |
| [REDACTED] | | | | | | | [REDACTED] | |

Property Information:

| | | | | | | | |
|------------------------------------|----------|---------|------|----------|------|-------|-------|
| Value of Stolen Property | Currency | Jewelry | Furs | Clothing | Auto | Misc. | Total |
| Value of Stolen Property Recovered | | | | | | | |

Automobile Information:

| 1 | Vehicle Code | Year | Make | Body Type | Model | Color | Registration | State | VIN |
|---|--------------|------|------|-----------|-------|-------|--------------|-------|-------------------|
| | Involved | 18 | BMW | WAGON | X5 | BLA | P88PMH | NJ | 5UXKR0C54J0Y02413 |
| 2 | | | | | | | | | |
| 3 | | | | | | | | | |
| 4 | | | | | | | | | |

Narrative:

[REDACTED NARRATIVE]

Officer of Record: PO Chase Elder 377 Date: 04/19/22 Other Reports Filed: MVA Arrest DV DWI DWIQ Tow SD CI TRO SHA Prop. Video UOF Prst Supp 1 Juv Bias Pris Reviewed By: cantinori



Teaneck Police Department

900 Teaneck Rd, Teaneck, NJ 07666

Phone: 201-837-2600 Fax: 201-837-1880 Mun. Code: 0260

Incident Report



Narrative Continued (Page 2)

Case Number

22-021785

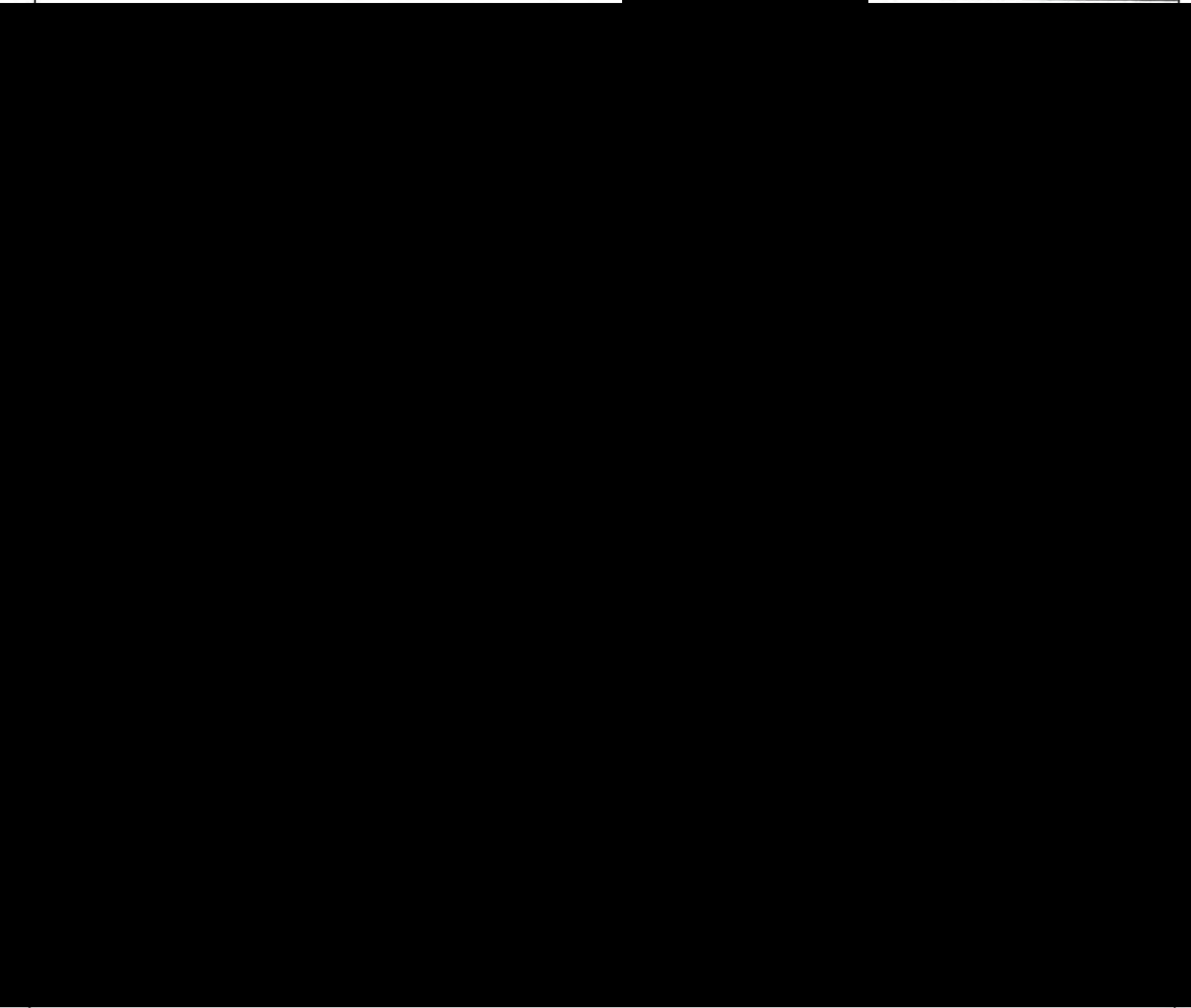

Officer of Record:

Date:

PO Chase Elder 377

04/19/22



Teaneck Police Department

900 Teaneck Rd, Teaneck, NJ 07666

Phone: 201-837-2600 Fax: 201-837-1880 Mun. Code: 0260

Incident Report



Narrative Continued (Page 3)

Case Number

22-024785

Photos of [REDACTED] injuries were scanned into this report as evidence.

Officer of Record:

Date:

PO Chase Elder 377

04/19/22



Teaneck Police Department

900 Teaneck Rd, Teaneck, NJ 07666

Phone: 201-837-2600 Fax: 201-837-1880 Mun. Code: 0260

Incident Report - Additional Contacts



Incident Details:

| | | | | | | | | | |
|-------------|---------------|---------------|---------------|---------------|---|---------------|---------------|-----|-----------|
| Case Number | Time Reportec | Date Reportec | Time Occurred | Date Occurred | Occurrence Between Date / Time of | Time Occurred | Date Occurred | 911 | Completed |
| 22-021785 | 12:30 | 04/19/22 | 12:30 | 04/19/22 | | | | X | X |

Incident Type:

Simple Assault 2C:12-1a

Incident Location:

| | | |
|---------------------------------|--------------|---------------------------------|
| Street # | Street Name | Intersection / Cross Street of: |
| 1340 | Teaneck Road | Teaneck Road / Orchard |
| Business / Common Location Name | | |

Contact Information: Victim Suspect Complainant Witness Driver Arrest Passenger Missing Business Other

| Code | Contact Name #: | MI | Suffix | Age | Sex | Race | DOB | SSN |
|------|-----------------|----|--------|-----|-----|------|-----|-----|
|------|-----------------|----|--------|-----|-----|------|-----|-----|

| | | |
|---------|------------|------------|
| Address | Home Phone | Cell Phone |
|---------|------------|------------|

| Code | Contact Name #: | MI | Suffix | Age | Sex | Race | DOB | SSN |
|------|-----------------|----|--------|-----|-----|------|-----|-----|
|------|-----------------|----|--------|-----|-----|------|-----|-----|

| | | |
|---------|------------|------------|
| Address | Home Phone | Cell Phone |
|---------|------------|------------|

| Code | Contact Name #: | MI | Suffix | Age | Sex | Race | DOB | SSN |
|------|-----------------|----|--------|-----|-----|------|-----|-----|
|------|-----------------|----|--------|-----|-----|------|-----|-----|

| | | |
|---------|------------|------------|
| Address | Home Phone | Cell Phone |
|---------|------------|------------|

| Code | Contact Name #: | MI | Suffix | Age | Sex | Race | DOB | SSN |
|------|-----------------|----|--------|-----|-----|------|-----|-----|
|------|-----------------|----|--------|-----|-----|------|-----|-----|

| | | |
|---------|------------|------------|
| Address | Home Phone | Cell Phone |
|---------|------------|------------|

Officer of Date Other Reports Filed: Reviewed

| | | | | | | | | | | |
|--------------------|----------|---------------|------|-----|------|--------|-----|------|------|-------|
| PO Chase Elder 377 | 04/19/22 | MVA <T Arrest | DV | DWI | DWIQ | Tow | SD | CI | TRO | CANTI |
| | | SHA Prop | Evdn | UOF | Prst | Supp X | Juv | Bias | Pris | |



Teaneck Police Department

900 Teaneck Rd, Teaneck, NJ 07666

Phone: 201-837-2600 Fax: 201-837-1880 Mun. Code: 0260

Incident Report



Incident Details:

| | | | | | | | | | |
|-------------|---------------|---------------|---------------|---------------|-----------------------------------|---------------|---------------|-----|-----------|
| Case Number | Time Reported | Date Reported | Time Occurred | Date Occurred | Occurrence Between Date / Time of | Time Occurred | Date Occurred | 911 | Completed |
| 22-035152 | 12:08 | 06/20/22 | 12:08 | 06/20/22 | | 17:00 | 06/14/22 | | X |

Incident Type:

Theft 2C:20-3

Incident Location:

Street # Street Name Intersection / Cross Street of:
 1340 Teaneck Road Teaneck Road / Orchard St
 Business / Common Location Name

Contact Information: Victim Suspect Complainant Witness Driver Arrest Passenger Missing Involved Other

| Code | Contact Name #1 | MI | Suffix | Age | Sex | Race | DOB | SSN |
|------|-----------------|----|--------|-----|-----|------|-----|-----|
|------|-----------------|----|--------|-----|-----|------|-----|-----|

| | | |
|---------|------------|------------|
| Address | Home Phone | Cell Phone |
|---------|------------|------------|

| Code | Contact Name #2 | MI | Suffix | Age | Sex | Race | DOB | SSN |
|------|-----------------|----|--------|-----|-----|------|-----|-----|
|------|-----------------|----|--------|-----|-----|------|-----|-----|

| | | |
|---------|------------|------------|
| Address | Home Phone | Cell Phone |
|---------|------------|------------|

| Code | Contact Name #3 | MI | Suffix | Age | Sex | Race | DOB | SSN |
|------|-----------------|----|--------|-----|-----|------|-----|-----|
|------|-----------------|----|--------|-----|-----|------|-----|-----|

| | | |
|---------|------------|------------|
| Address | Home Phone | Cell Phone |
|---------|------------|------------|

| Code | Contact Name #4 | MI | Suffix | Age | Sex | Race | DOB | SSN |
|------|-----------------|----|--------|-----|-----|------|-----|-----|
|------|-----------------|----|--------|-----|-----|------|-----|-----|

| | | |
|---------|------------|------------|
| Address | Home Phone | Cell Phone |
|---------|------------|------------|

Property Information:

| Value of Stolen Property | Currency | Jewelry | Furs | Clothing | Auto | Misc. | Total |
|------------------------------------|----------|---------|------|----------|------|-------|-------|
| | | | | | | | |
| Value of Stolen Property Recovered | | | | | | | |

Automobile Information:

| 1 | Vehicle Code | Year | Make | Body Type | Model | Color | Registration | State | VIN |
|---|--------------|------|------|-----------|-------|-------|--------------|-------|-------------------|
| | Damaged | 06 | HON | 4 DR | ACC | BL | N93GSD | NJ | 1HGCM56836A049547 |
| 2 | | | | | | | | | |
| 3 | | | | | | | | | |
| 4 | | | | | | | | | |

Narrative:

On Monday, June 20, 2022, at approximately 12:08 PM, Detective K. Florio #349 and I responded to Leasco (1340 Teaneck Road), on a report of a possible catalytic converter taken from vehicle. I responded in motor patrol vehicle #14 in routine manner.

Upon arrival, I observed a 2006 blue Honda Accord parked in the rear parking lot of 1340 Teaneck Road, facing the east direction. I spoke with the caller [REDACTED], identified as the owner of the aforementioned vehicle.

Officer of Record: Date: Other Reports Filed: Reviewed By:

| | | | |
|--------------------|----------|---|----------|
| PO Kevin Gibbs 363 | 06/20/22 | MVA Arrest DV DWI DWIQ Tow SD CI TRO SHA Prop. Video UOF Prst Supp Juv Bias Pris | jgarland |
|--------------------|----------|---|----------|



Teaneck Police Department

900 Teaneck Rd, Teaneck, NJ 07666

Phone: 201-837-2600 Fax: 201-837-1880 Mun. Code: 0260

Incident Report



Narrative Continued (Page 2)

Case Number

22-035152

██████████ reported that on Tuesday, June 14, 2022, at approximately 5:00 PM, he parked the vehicle in a designated parking spot upon receiving the vehicle as a trade-in. He further reported on today, Monday, June 20, 2022, at approximately 10:00 PM, he attempted to start to start the vehicle and reported the vehicle began to produce a loud and continuous rumbling sound.

While conducting an investigation, a canvass for surveillance footage was conducted, yielding surveillance footage on the rear of the building. ██████████ reported he was unable to observe any suspicious activity within the time frame provide but mentioned he would be sending the footage to Det. Florio for further review.

A NJ Victim Notification Form (NJVNF) was completed and signed for, with ██████████ receiving a copy for personal documentation.

All forms were later scanned and can be found attached to this report.

Officer of Record:

Date:

PO Kevin Gibbs 363

06/20/22



Teaneck Police Department

900 Teaneck Rd, Teaneck, NJ 07666

Phone: 201-837-2600 Fax: 201-837-1880 Mun. Code: 0260

Incident Report



Incident Details:

| | | | | | | | | | |
|-------------|---------------|---------------|---------------|---------------|-----------------------------------|---------------|---------------|-----|-----------|
| Case Number | Time Reported | Date Reported | Time Occurred | Date Occurred | Occurrence Between Date / Time of | Time Occurred | Date Occurred | 911 | Completed |
| 18-064649 | 15:27 | 12/30/18 | 15:27 | 12/30/18 | | | | X | X |

Incident Type:

Disturbance / Noise Complaint

Incident Location:

Street # Street Name Intersection / Cross Street of:
 1334 Teaneck Road Orchard St / Teaneck Road
 Business / Common Location Name

Contact Information: Victim Suspect Complainant Witness Driver Arrest Passenger Missing Involved Other

| | | | | | | | | |
|------|-----------------|----|--------|-----|-----|------|-----|-----|
| Code | Contact Name #1 | MI | Suffix | Age | Sex | Race | DOB | SSN |
|------|-----------------|----|--------|-----|-----|------|-----|-----|

Address Home Phone Cell Phone

| | | | | | | | | |
|------|-----------------|----|--------|-----|-----|------|-----|-----|
| Code | Contact Name #2 | MI | Suffix | Age | Sex | Race | DOB | SSN |
|------|-----------------|----|--------|-----|-----|------|-----|-----|

Address Home Phone Cell Phone

| | | | | | | | | |
|------|-----------------|----|--------|-----|-----|------|-----|-----|
| Code | Contact Name #3 | MI | Suffix | Age | Sex | Race | DOB | SSN |
|------|-----------------|----|--------|-----|-----|------|-----|-----|

Address Home Phone Cell Phone

| | | | | | | | | |
|------|-----------------|----|--------|-----|-----|------|-----|-----|
| Code | Contact Name #4 | MI | Suffix | Age | Sex | Race | DOB | SSN |
|------|-----------------|----|--------|-----|-----|------|-----|-----|

Address Home Phone Cell Phone

Property Information:

| | | | | | | | |
|------------------------------------|----------|---------|------|----------|------|-------|-------|
| Value of Stolen Property | Currency | Jewelry | Furs | Clothing | Auto | Misc. | Total |
| Value of Stolen Property Recovered | | | | | | | |

Automobile Information:

| 1 | Vehicle Code | Year | Make | Body Type | Model | Color | Registration | State | VIN |
|---|--------------|------|------|-----------|-------|-------|--------------|-------|-------------------|
| | | 10 | LEX | WAGON | RX | RD | U39DZN | NJ | 2T2BK1BA6AC079319 |
| 2 | | | | | | | | | |
| 3 | | | | | | | | | |
| 4 | | | | | | | | | |

Narrative:

On Sunday, December 30 2018, at 3:27 p.m., Sgt. Croonquist 266, PO Randy Morales 306 and I were dispatched to Elsa's Beauty Salon, 1334 Teaneck Road, on a report of a verbal dispute.

We arrived on scene I observed two females, later identified as M [redacted] [redacted] having a verbal dispute on the street in front of Elsa's Beauty Salon. The verbal dispute ensued because of a discrepancy on the price for [redacted] daughter's hair [redacted] stated for the service provided the cost would amount to \$50.00 [redacted] stated that was not the price she believed the hair styling was worth and was only willing to pay \$40.00

Officer of Record: Date: Other Reports Filed: Reviewed By:

| | | | | |
|---------------------|----------|--------------------------------------|---|-------------|
| PO Zachary Reed 352 | 12/30/18 | MVA Arrest DV DWI DWIQ Tow SD CI TRO | SHA Prop. Video UOF Prst Supp Juv Bias Pris | wcroonquist |
|---------------------|----------|--------------------------------------|---|-------------|



Teaneck Police Department

900 Teaneck Rd, Teaneck, NJ 07666

Phone: 201-837-2600 Fax: 201-837-1880 Mun. Code: 0260

Incident Report



Narrative Continued (Page 2)

Case Number

18-064649

[REDACTED] stated she left \$45.00 for [REDACTED] for the services rendered. According to [REDACTED] she told her daughter, "NF" to leave the store. As the daughter was attempting to leave the store [REDACTED] stood in the doorway and grabbed "NF's" arm and pushed her back into the store to prevent her from leaving. "NF" managed to exit the store and enter her mother's vehicle. [REDACTED] attempted to get into her vehicle and leave the scene. [REDACTED] told her to wait until the police arrived.

[REDACTED] z stated [REDACTED] told her daughter to leave the store. As "NF" was attempting to leave the store [REDACTED] said she stepped into the doorway to prevent her from leaving. [REDACTED] z stated that she never put her hands on "NF". [REDACTED] stated "NF" was able to exit the store. [REDACTED] went to her vehicle and opened the drivers side door and attempted to leave the scene. [REDACTED] told Ms. [REDACTED] not to leave and wait until the police arrive.

There was no video surveillance to confirm or deny either parties story. Both parties were separated and were advised a report would be written by me. Both parties were informed they can sign complaints against one another at the Teaneck Municipal Court. [REDACTED] z was willing to accept the \$45.00 for the services rendered. At the request of [REDACTED] was also advised by me that she is not welcome back at that store and if she would return it would be an offense of Defiant Trespass.

Submitted By: PO Zachary Reed 352

Officer of Record:

Date:

PO Zachary Reed 352

12/30/18



Teaneck Police Department

900 Teaneck Rd, Teaneck, NJ 07666

Phone: 201-837-2600 Fax: 201-837-1880 Mun. Code: 0260

CAD Report



| Incident Details: | | | Incident Location: | | Disposition |
|-------------------|-------|----------|--------------------------------|--|------------------|
| Case Number | Time | Date | Address | | Disposition |
| PD-17-023816 | 19:06 | 06/25/17 | 27 ORCHARD ST, TEANECK TWP, NJ | | Report Completed |

| Incident Type: | | Dispatched By | | Created By | |
|--------------------------------|---------|-----------------|---------|--------------|---------|
| First Aid / Medical Assistance | | Bcoym | | Dkazm | |
| Unit | Officer | Unit | Officer | Unit | Officer |
| 340 | Jmeyer | | | | |
| Time Received | | Time Dispatched | | Time Arrived | |
| 1906 | | 1937 | | 1937 | |

| Contact Information: | | | | | |
|----------------------|--------------|---------|-----|-----|------------|
| Role | Contact Name | Address | DOB | Sex | Race Phone |
| | | | | | |
| | | | | | |
| | | | | | |
| | | | | | |
| | | | | | |
| | | | | | |
| | | | | | |
| | | | | | |
| | | | | | |

| Auto Information: | | | | | | |
|-------------------|-------|------|-------|-------|------|-----|
| Registration | State | Make | Model | Color | Year | VIN |
| | | | | | | |
| | | | | | | |
| | | | | | | |

| Summonses: | | | | |
|---------------|------|-----------|------|---------|
| Ticket Number | Date | Violation | Name | Officer |
| | | | | |
| | | | | |
| | | | | |

Narrative:
 Input bcoym 06 25 2017 19 07 20 Edited bcoym 06 25 2017 19 07 20 61 YO MALE PASSED OUT NOW ALERT AND CONSCIOUS Input bcoym 06 25 2017 19 07 34 Edited bcoym 06 25 2017 19 07 34 MEDICS NOTIFIED Input bcoym 06 25 2017 19 07 41 Edited bcoym 06 25 2017 19 07 41 6462033785 Input dkazm 06 25 2017 19 37 15 Edited dkazm 06 25 2017 19 37 15 1 TO HOLY NAME Input dkazm 06 25 2017 19 37 32 Edited dkazm 06 25 2017 19 37 32 340 ASIGNED FOR REPORT BUT DID NOT RESPOND



Teaneck Police Department

900 Teaneck Rd, Teaneck, NJ 07666

Phone: 201-837-2600 Fax: 201-837-1880 Mun. Code: 0260

Incident Report



| Incident Details: | | | Incident Location: | Disposition |
|-------------------|-------|----------|--------------------------------|------------------|
| Case Number | Time | Date | Address | Disposition |
| PD-18-006243 | 11:59 | 02/14/18 | 27 ORCHARD ST, TEANECK TWP, NJ | Report Completed |

| Incident Type: |
|-----------------------------|
| Flim-flam / Confidence Game |

| Narrative | Officer | Approving Officer |
|-----------|---------|-------------------|
| | rmora | |

On Wednesday February 14th 20018 [REDACTED] responded to Teaneck Police Headquarters to report an attempted fraud. [REDACTED] stated that on February 12th 2018 she received an email from Saska Technologies [REDACTED] recruiting her for employment with their corporation [REDACTED] replied to the email expressing interest in the position and was given a time for an online interview on the Google Hangouts App. [REDACTED] completed what she at the time believed to be an online interview with a [REDACTED] who claimed to be the hiring manager. Shortly after the interview she was informed that she was going to be offered a position by a [REDACTED] via email and that an offer of employment would be sent to her. After accepting the offer [REDACTED] continued to communicate with [REDACTED] on the Google Hangouts App. [REDACTED] advised that he would be sending a check to her via Fedex. Upon receipt of the check [REDACTED] was to deposit it to her account either through the phone app for Bank of America or by depositing into an ATM. The check was to be used to purchase some hardware to set up her home office. After making the deposit the deposit slip was to be sent to Saska Technologies for verification. On this date [REDACTED] received a cashiers check 417749 issued by Mountain America Federal Credit Union in the amount of 4 620.00. The check was sent to [REDACTED] via Fedex tracking [REDACTED] was unsure if the check was valid and responded to Bank of America 790 Palisade Avenue and questioned the teller there. At that time [REDACTED] was advised that the check was fraudulent and to report it to this department. [REDACTED] turned over the check the Fedex envelope and a copy of her email correspondences. She was given a copy of each item for her records and the originals were secured into evidence by me. A Victim Notification Form was completed and signed by [REDACTED] before it was faxed to the Office of Victim Witness Advocacy in Hackensack NJ by me. [REDACTED] stated that she would attempt to make hard copies of her conversations on Google Hangouts to be included with this report. A Google search of Saska Technologies makes several references to it being a scam. I was unable to locate any information for a [REDACTED] or a [REDACTED] as employees of the company. Submitted By PO Randy Morales 306



Teaneck Police Department

900 Teaneck Rd, Teaneck, NJ 07666

Phone: 201-837-2600 Fax: 201-837-1880 Mun. Code: 0260

Incident Report



Incident Details:

| | | | | | | | | | |
|-------------|---------------|---------------|---------------|---------------|-----------------------------------|---------------|---------------|-----|-----------|
| Case Number | Time Reported | Date Reported | Time Occurred | Date Occurred | Occurrence Between Date / Time of | Time Occurred | Date Occurred | 911 | Completed |
| 18-022570 | 22:08 | 05/29/18 | 22:08 | 05/30/18 | | | | | X |

Incident Type:

Medical Emergency

Incident Location:

Street # Street Name Intersection / Cross Street of:
 27 Orchard St Orchard St / Teaneck Road
 Business / Common Location Name

Contact Information: Victim Suspect Complainant Witness Driver Arrest Passenger Missing Involved Other

| Code | Contact Name #1 | MI | Suffix | Age | Sex | Race | DOB | SSN |
|------------|-----------------|----|--------|-----|-----|------------|--------------|------------|
| I | [REDACTED] | | | 57 | F | | 0 [REDACTED] | |
| Address | | | | | | Home Phone | | Cell Phone |
| [REDACTED] | | | | | | [REDACTED] | | |
| Code | Contact Name #2 | MI | Suffix | Age | Sex | Race | DOB | SSN |
| | | | | | | | | |
| Address | | | | | | Home Phone | | Cell Phone |
| [REDACTED] | | | | | | [REDACTED] | | |
| Code | Contact Name #3 | MI | Suffix | Age | Sex | Race | DOB | SSN |
| | | | | | | | | |
| Address | | | | | | Home Phone | | Cell Phone |
| [REDACTED] | | | | | | [REDACTED] | | |
| Code | Contact Name #4 | MI | Suffix | Age | Sex | Race | DOB | SSN |
| | | | | | | | | |
| Address | | | | | | Home Phone | | Cell Phone |
| [REDACTED] | | | | | | [REDACTED] | | |

Property Information:

| Value of Stolen Property | Currency | Jewelry | Furs | Clothing | Auto | Misc. | Total |
|------------------------------------|----------|---------|------|----------|------|-------|-------|
| | | | | | | | |
| Value of Stolen Property Recovered | | | | | | | |

Automobile Information:

| 1 | Vehicle Code | Year | Make | Body Type | Model | Color | Registration | State | VIN |
|---|--------------|------|------|-----------|-------|-------|--------------|-------|-----|
| 2 | | | | | | | | | |
| 3 | | | | | | | | | |
| 4 | | | | | | | | | |

Narrative:

[Empty Narrative Box]

Officer of Record: Date: Other Reports Filed: Reviewed By:

| | | |
|--------------------------------|---|---------|
| PO Stephen Morena 338 05/29/18 | MVA Arrest DV DWI DWIQ Tow SD CI TRO SHA Prop. Video UOF Prst Supp Juv Bias Pris | gwright |
|--------------------------------|---|---------|



Teaneck Police Department

900 Teaneck Rd, Teaneck, NJ 07666

Phone: 201-837-2600 Fax: 201-837-1880 Mun. Code: 0260

Incident Report



Incident Details:

| | | | | | | | | | |
|-------------|---------------|---------------|---------------|---------------|-----------------------------------|---------------|---------------|-----|-----------|
| Case Number | Time Reported | Date Reported | Time Occurred | Date Occurred | Occurrence Between Date / Time of | Time Occurred | Date Occurred | 911 | Completed |
| 19-066515 | 11:12 | 12/06/19 | 11:12 | 12/06/19 | | | | X | X |

Incident Type:

Medical Emergency

Incident Location:

Street # Street Name Intersection / Cross Street of:
 27 Orchard St Orchard St / Teaneck Road
 Business / Common Location Name

Contact Information: Victim Suspect Complainant Witness Driver Arrest Passenger Missing Involved Other

| Code | Contact Name #1 | MI | Suffix | Age | Sex | Race | DOB | SSN |
|------------|-----------------|----|--------|-----|-----|------------|------------|------------|
| C | [REDACTED] | | | 58 | F | 2B | [REDACTED] | [REDACTED] |
| Address | | | | | | Home Phone | | Cell Phone |
| [REDACTED] | | | | | | [REDACTED] | | [REDACTED] |
| Code | Contact Name #2 | MI | Suffix | Age | Sex | Race | DOB | SSN |
| | | | | | | | | |
| Address | | | | | | Home Phone | | Cell Phone |
| [REDACTED] | | | | | | [REDACTED] | | [REDACTED] |
| Code | Contact Name #3 | MI | Suffix | Age | Sex | Race | DOB | SSN |
| | | | | | | | | |
| Address | | | | | | Home Phone | | Cell Phone |
| [REDACTED] | | | | | | [REDACTED] | | [REDACTED] |
| Code | Contact Name #4 | MI | Suffix | Age | Sex | Race | DOB | SSN |
| | | | | | | | | |
| Address | | | | | | Home Phone | | Cell Phone |
| [REDACTED] | | | | | | [REDACTED] | | [REDACTED] |

Property Information:

| | | | | | | | |
|------------------------------------|----------|---------|------|----------|------|-------|-------|
| Value of Stolen Property | Currency | Jewelry | Furs | Clothing | Auto | Misc. | Total |
| Value of Stolen Property Recovered | | | | | | | |

Automobile Information:

| 1 | Vehicle Code | Year | Make | Body Type | Model | Color | Registration | State | VIN |
|---|--------------|------|------|-----------|-------|-------|--------------|-------|-----|
| 2 | | | | | | | | | |
| 3 | | | | | | | | | |
| 4 | | | | | | | | | |

Narrative:

Party reporting dizziness. Transported by TVAC to HNH.

Officer of Record: Date: Other Reports Filed: Reviewed By:

| | | | |
|---------------------|----------|---|---------|
| PO Kevin Florio 349 | 12/06/19 | MVA Arrest DV DWI DWIQ Tow SD CI TRO SHA Prop. Video UOF Prst Supp Juv Bias Pris | dalcott |
|---------------------|----------|---|---------|



Teaneck Police Department

900 Teaneck Rd, Teaneck, NJ 07666

Phone: 201-837-2600 Fax: 201-837-1880 Mun. Code: 0260

Incident Report



Incident Details:

| | | | | | | | | | |
|-------------|---------------|---------------|---------------|---------------|-----------------------------------|---------------|---------------|-----|-----------|
| Case Number | Time Reported | Date Reported | Time Occurred | Date Occurred | Occurrence Between Date / Time of | Time Occurred | Date Occurred | 911 | Completed |
| 20-040106 | 13:45 | 08/13/20 | 13:45 | 08/13/20 | | | | X | X |

| | |
|---|--|
| Incident Type: | Incident Location: |
| Transportation - Courtesy Psych Case | Street # Street Name 27 Orchard St Intersection / Cross Street of: Orchard St / Teaneck Road Business / Common Location Name |

| Contact Information: | | | | | | | | | |
|----------------------|-----------------|-------------|------------|------------|------------|------------|------------|------------|------------|
| Victim | Suspect | Complainant | Witness | Driver | Arrest | Passenger | Missing | Involved | Other |
| Code | Contact Name #1 | MI Suffix | Age | Sex | Race | DOB | SSN | | |
| I | [REDACTED] | D | [REDACTED] | [REDACTED] | [REDACTED] | [REDACTED] | [REDACTED] | [REDACTED] | [REDACTED] |
| | | | | | | Home Phone | Cell Phone | | |
| | | MI Suffix | Age | Sex | Race | DOB | SSN | | |
| | Address | | | | | Home Phone | Cell Phone | | |
| Code | Contact Name #3 | MI Suffix | Age | Sex | Race | DOB | SSN | | |
| | Address | | | | | Home Phone | Cell Phone | | |
| Code | Contact Name #4 | MI Suffix | Age | Sex | Race | DOB | SSN | | |
| | Address | | | | | Home Phone | Cell Phone | | |

| Property Information: | | | | | | | |
|------------------------------------|----------|---------|------|----------|------|-------|-------|
| Value of Stolen Property | Currency | Jewelry | Furs | Clothing | Auto | Misc. | Total |
| Value of Stolen Property Recovered | | | | | | | |

| Automobile Information: | | | | | | | | | |
|-------------------------|--------------|------|------|-----------|-------|-------|--------------|-------|-----|
| 1 | Vehicle Code | Year | Make | Body Type | Model | Color | Registration | State | VIN |
| 2 | | | | | | | | | |
| 3 | | | | | | | | | |
| 4 | | | | | | | | | |

Narrative:
 On Thursday, August 13, 2020, at approximately 1:45 PM, Officer R. Gloria # and I responded to 27 Orchard St, on a female party requesting psychiatric help. I responded in motor patrol vehicle #11, in a routine manner.



| | | | |
|---------------------------|--------------|---|---------------------|
| Officer of Record: | Date: | Other Reports Filed: | Reviewed By: |
| PO Antherson Ramirez | 08/13/20 | MVA Arrest DV DWI DWIQ Tow SD CI TRO SHA Prop. Video UOF Prst Supp Juv Bias Pris | pforrest |



Teaneck Police Department

900 Teaneck Rd, Teaneck, NJ 07666

Phone: 201-837-2600 Fax: 201-837-1880 Mun. Code: 0260

Incident Report



Narrative Continued (Page 2)

Case Number

86-210100

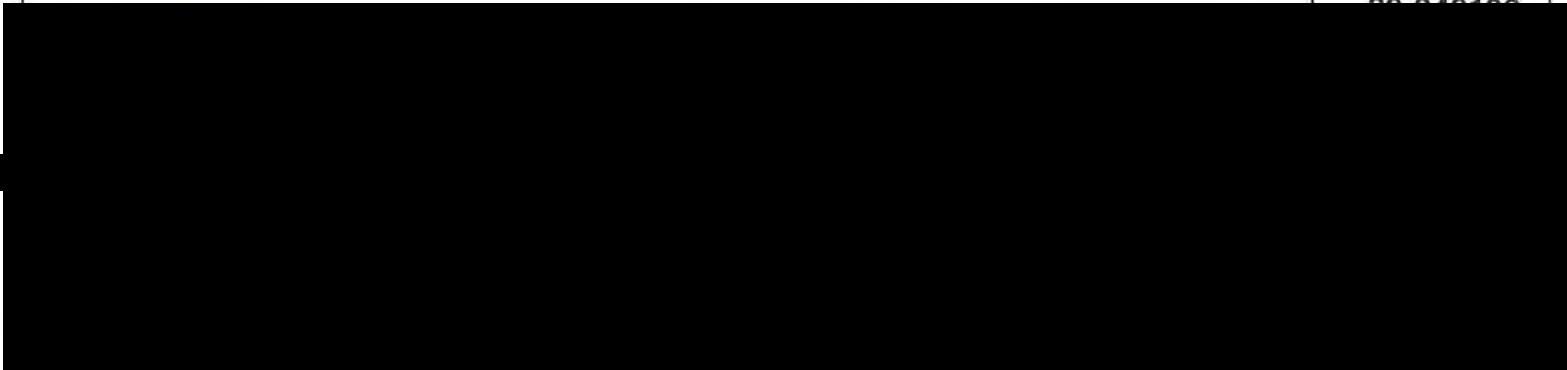

The above incident and transport was recorded in the Mobile Video Recorder (MVR) in motor patrol vehicles #10 and #11.

Officer of Record:

Date:

PO Antherson Ramirez 350

08/13/20



Teaneck Police Department

900 Teaneck Rd, Teaneck, NJ 07666

Phone: 201-837-2600 Fax: 201-837-1880 Mun. Code: 0260



Incident Report

| Incident Details: | | | Incident Location: | Disposition |
|-------------------|-------|----------|---------------------------------|------------------|
| Case Number | Time | Date | Address | Disposition |
| PD-17-038015 | 08:27 | 10/16/17 | 1335 GRAHAM PL, TEANECK TWP, NJ | Report Completed |

| Incident Type: | |
|-------------------------|--|
| Burglary Unlawful Entry | |

| Narrative | Officer | Approving Officer |
|-----------|---------|-------------------|
| | wdrin | |

On October 16 2017 Officer S. Batista 325 and I were dispatched to 1335 Graham Place on a report of a door that was opened to an abandoned house. Upon our arrival I spoke with the caller [REDACTED]. She stated that the house behind hers was abandoned and the back door of the residence was opened. She stated that it has been open for approximately three days she just did not have the time to call the Teaneck Police. Officer Batista and I then went to 1335 Graham Place. The residence appeared that it had been vacant for a while. Upon approaching the rear of the residence I observed an open door. The door had a lock on it with hinges attached to the lock. It appeared that the hinges of the door had either been forced open or the screws holding the lock together had been unscrewed. At this time Officer Batsita and I conducted an interior search of the residence. In the living room and basement area it appeared that the residence had been vacant for some time. In the upstairs bedroom area it appeared that a unknown party could have been using the residence at this time. In the bedroom were clothes and a bed that could have been occupied. Officer G. Skoufas 327 and Special M. Piterski 2 arrived on scene at this time. BCI was not called due to no record of an owner on file for the residence. The Teaneck Fire Department were called to secure the house. The Teaneck Fire Department arrived on scene at this time. Teaneck FD A. Wrenn 106 secured the residence at this time. A victim notification form could not be filled due to there being no homeowner for the vacant residence. Officer Wesley Drinker 347



Teaneck Police Department

900 Teaneck Rd, Teaneck, NJ 07666

Phone: 201-837-2600 Fax: 201-837-1880 Mun. Code: 0260

Incident Report



Incident Details:

| | | | | | | | | | |
|-------------|---------------|---------------|---------------|---------------|-----------------------------------|---------------|---------------|-----|-----------|
| Case Number | Time Reported | Date Reported | Time Occurred | Date Occurred | Occurrence Between Date / Time of | Time Occurred | Date Occurred | 911 | Completed |
| 19-071436 | 15:06 | 12/31/19 | 15:06 | 12/31/19 | | | | X | X |

Incident Type:

Criminal Trespass 2C:18-3

Incident Location:

Street # Street Name Intersection / Cross Street of:
Graham Pl / Mersereau Ter

Contact Information: Victim S

[Redacted]

Code Contact Name #2

[Redacted]

Address [Redacted]

[Redacted]

Report redacted due to contact #2's expungement

Passenger Missing Involved Other

[Redacted]

DOB SSN

[Redacted]

Cell Phone [Redacted]

DOB SSN

[Redacted]

Cell Phone [Redacted]

SSN [Redacted]

[Redacted]

Home Phone Cell Phone

Property Information:

| | | | | | | | |
|------------------------------------|----------|---------|------|----------|------|-------|-------|
| Value of Stolen Property | Currency | Jewelry | Furs | Clothing | Auto | Misc. | Total |
| Value of Stolen Property Recovered | | | | | | | |

Automobile Information:

| 1 | Vehicle Code | Year | Make | Body Type | Model | Color | Registration | State | VIN |
|---|--------------|------|------|-----------|-------|-------|--------------|-------|-----|
| 2 | | | | | | | | | |
| 3 | | | | | | | | | |
| 4 | | | | | | | | | |

Narrative:

On Wednesday, December 31, 2019, at approximately 3:06 PM, all available officers responded to the residence located at the address of 1335 Graham Place, on the report of a burglary in progress. I responded to the scene in marked patrol vehicle #19, with emergency lights and audible sirens activated. During our response, we were advised by dispatch that the actors had fled the area. Preliminary descriptions reported two actors, a male and a female, last seen heading north, on foot, in the direction of West Englewood Avenue.

I was the first officer on scene. As I was turning onto Graham Place, I observed a white Dodge Charger, traveling in the opposite direction, at what appeared to be a relatively high rate of speed.

Officer of Record:

PO Kevin Florio 349 12/31/19

Date:

Other Reports Filed:

MVA Arrest 3 DV DWI DWIQ Tow SD CI TRO
SHA Prop. Video UOF Prst Supp 2 Juv Bias Pris 2

Reviewed By:

jgarland



Teaneck Police Department

900 Teaneck Rd, Teaneck, NJ 07666

Phone: 201-837-2600 Fax: 201-837-1880 Mun. Code: 0260

Incident Report



Narrative Continued (Page 2)

Case Number
19-071436

Initially unsure as to whether or not this vehicle was involved in the incident in which we were responding to, I stopped the vehicle and began speaking with the operator. After some brief investigation, it became clear that the operator of this vehicle had been involved in a domestic violence dispute, which had just occurred at the address of 61 Graham Place, a neighboring residence to the one in which the burglary in progress had been reported. This incident of domestic violence had not yet been reported to police. The incidents seemed to be entirely separate of one another, having just coincidentally occurred simultaneously. Officer Michael Apreda #355 is the officer of record for that incident, please refer to his report, 19-071442, for a more detailed description of events. As other officers arrived, I allowed them to continue speaking with the parties involved, while I hurriedly proceeded down the street to 1335 Graham Place, to meet with the caller who had reported the original incident.

I spoke with the complainant, [REDACTED]. He reported that he responded to his property, which is currently under construction, and observed two unknown parties loitering within. Upon seeing him arrive, both parties, a male and a female, exited the residence. They were then approached by [REDACTED]. He questioned both individuals and stated that both parties could not specify the reason why they were present inside of the property. After a short time speaking with them, the male party, later identified as [REDACTED] fled. He ran through the residence's backyard and jumped over the fence. He was last seen traveling northbound on foot. The female party, later identified as [REDACTED] continued talking with Mr. Marine for a short time before departing, walking westbound on Graham Place, before turning right and heading northbound to West Englewood Avenue.

[REDACTED] escorted me inside the residence. He noted that since the house is in the preliminary stages of development (currently implementing electrical components), he had not yet placed a lock on the front door, and thus, the two actors did not appear to have forced entry into the home. I observed an assortment of open containers of alcohol, centered around makeshift seating, such as cinderblocks which had been stood upright. I took two pictures of this area, which can be found attached. [REDACTED] stated that he did not believe anything had been stolen from the home, reiterating that there was not much to steal in the first place. He provided me with a picture of the female actor, taken by him when he first confronted her. I immediately forwarded this picture to the other officers, who were currently searching for the suspects. Mr. [REDACTED] also provided a description of the male actor. He described the party as a middle aged Hispanic male, wearing gray pants with a gray sweatshirt and a black jacket, with a black fleece winter cap. This information was also immediately relayed to the other officers.

Officer Michael Ayala #332, who was searching the area, observed two parties matching the aforementioned descriptions standing outside of Walgreens, located at the address of 1400 Teaneck Road. He called for additional officers, prior to stopping and approaching the parties. Detective Babajide Olamiju #343 and Officer Antherson Ramirez #350 responded to assist. [REDACTED] and Ms. McCain were immediately separated and questioned. During the questioning,

Officer of Record: [REDACTED] **Date:** [REDACTED]

PO Kevin Florio 349 12/31/19



Teaneck Police Department

900 Teaneck Rd, Teaneck, NJ 07666

Phone: 201-837-2600 Fax: 201-837-1880 Mun. Code: 0260

Incident Report



Narrative Continued (Page 3)

Case Number

19-071436

[REDACTED] admitted that the two of them had entered the home, in order to relax and "drink a beer". Both he and Ms [REDACTED] were handcuffed and placed under arrest for Criminal Trespass and subsequently searched incident to that arrest. [REDACTED] was placed in the rear of marked patrol vehicle #18, driven by Officer Ayala, in preparation for transport to Teaneck Police headquarters. [REDACTED] was placed in the rear of marked patrol vehicle #16, driven by Officer Ramirez, in preparation for transport. Transport was begun to Teaneck Police Headquarters and was completed without incident.

I was still on scene with [REDACTED] at the time the arrests were made. I notified him that the suspects were in custody and provided him with a completed Victim Notification Form. A copy was later faxed to the Bergen County Victim/Witness office and can also be found scanned into this report.

Upon arrival at Teaneck Police Headquarters, the arrestees were led into the processing area one at a time, starting with [REDACTED]. Prior to entering the processing area, all officers secured their weapons in the designated gun lockers, as per department protocol. His personal property was collected and he was searched once more. Since [REDACTED] was waiting to be processed, the processing for [REDACTED] was not completed in full, prior to him being placed in male holding cell #M1. [REDACTED] was then led into the processing area, her personal property was collected and she was searched by Sergeant Jeannette Williams #278. She was then placed in female holding cell #F2.

[REDACTED]

[REDACTED] was then led from the holding cell to the processing area. Her personal property was searched and inventoried thoroughly. During the course of the inventory/search of [REDACTED] property, a clear plastic bag, containing 69 blue pills with the letter "v" imprinted on them, was located in [REDACTED] purse. The pills, suspected of being Alprazolam, more commonly referred to as Xanax, typically are prescribed by doctors to treat anxiety disorders.

Officer of Record: PO Kevin Florio 349 Date: 12/31/19



Teaneck Police Department

900 Teaneck Rd, Teaneck, NJ 07666

Phone: 201-837-2600 Fax: 201-837-1880 Mun. Code: 0260

Incident Report



Narrative Continued (Page 4)

Case Number
19-071436

This medication is only accessible via doctor's prescription and must be transported in a labeled bottle. The pills found in [REDACTED] purse were later entered into evidence [REDACTED] processing was completed, she was photographed and fingerprinted, prior to being led back to female holding cell #F2.

During this time, it was discovered that there was an active warrant for [REDACTED] arrest. Warrant No: W 2013 000733, from the City of Passaic, in the amount of \$750.00. The Passaic City Police Department was subsequently contacted and notified of [REDACTED] arrest. Shortly thereafter, Passaic indicated that Ms. [REDACTED] would be released on her own recognizance, pending a future court date in Passaic City Municipal Court, on January 2, 2020, at 9:00 AM. The ROR form provided by Passaic, was later signed by Ms. [REDACTED] and faxed to Passaic City Police Department.

Sergeant Robert Harvey #286 contacted Judge Giuseppe Randazzo and provided him with a detailed description of the events pertaining to the incident. The Judge was also advised that [REDACTED] accumulated a PSA score of 6. Judge Randazzo, after reviewing the facts of the incident, advised that Ms. [REDACTED] would be charged on a warrant and remanded to Bergen County Jail.

[REDACTED] was charged on Teaneck Complaint Warrant: 0260 W 2019 000482 with the following offenses:

1. Criminal Trespass, in violation of N.J.S. 2C:18-3A, a crime of the fourth degree.
2. Possession of Prescription Legend Drugs without a prescription, in violation of N.J.S. 2C:35-10.5E(2), a crime of the fourth degree.

[REDACTED] was later removed from the holding cell, her charges were read to her and she was subsequently transported to Bergen County Jail by Officer Dimitri Rueger #346 and Officer Jon-Ryan Meyer #340.

The response to the scene and the subsequent investigation in its entirety was recorded via Arbitrator Mobile Video Recorders (MVRs) affixed to marked patrol vehicles #19, #8 and #15.

| | |
|---------------------------|--------------|
| Officer of Record: | Date: |
| PO Kevin Florio 349 | 12/31/19 |



Teaneck Police Department

900 Teaneck Rd, Teaneck, NJ 07666

Phone: 201-837-2600 Fax: 201-837-1880 Mun. Code: 0260

Incident Report



| Incident Details: | | | | | | | | | |
|-------------------|---------------|---------------|---------------|---------------|-----------------------------------|---------------|---------------|-----|-----------|
| Case Number | Time Reported | Date Reported | Time Occurred | Date Occurred | Occurrence Between Date / Time of | Time Occurred | Date Occurred | 911 | Completed |
| 19-071436 | 15:06 | 12/31/19 | 15:06 | 12/31/19 | | | | X | X |

| Incident Type: | Incident Location: | | | | | | | | | |
|---------------------------------|---|---------------------------------|-------------|---------------------------------|------|-----------|---------------------------|---------------------------------|--|--|
| Criminal Trespass 2C:18-3 | <table border="1"> <tr> <td>Street #</td> <td>Street Name</td> <td>Intersection / Cross Street of:</td> </tr> <tr> <td>1335</td> <td>Graham Pl</td> <td>Graham Pl / Mersereau Ter</td> </tr> <tr> <td colspan="3">Business / Common Location Name</td> </tr> </table> | Street # | Street Name | Intersection / Cross Street of: | 1335 | Graham Pl | Graham Pl / Mersereau Ter | Business / Common Location Name | | |
| Street # | Street Name | Intersection / Cross Street of: | | | | | | | | |
| 1335 | Graham Pl | Graham Pl / Mersereau Ter | | | | | | | | |
| Business / Common Location Name | | | | | | | | | | |

Contact Information: Victim Suspect Complainant Witness Driver Arrest Passenger Missing Involved Other

| Property Information: | | | | | | | |
|------------------------------------|----------|---------|------|----------|------|-------|-------|
| Value of Stolen Property | Currency | Jewelry | Furs | Clothing | Auto | Misc. | Total |
| Value of Stolen Property Recovered | | | | | | | |

| Automobile Information: | | | | | | | | | |
|-------------------------|--------------|------|------|-----------|-------|-------|--------------|-------|-----|
| | Vehicle Code | Year | Make | Body Type | Model | Color | Registration | State | VIN |
| 1 | | | | | | | | | |
| 2 | | | | | | | | | |
| 3 | | | | | | | | | |
| 4 | | | | | | | | | |

Narrative:

On Wednesday, December 31, 2019, at approximately 3:06 PM, all available officers responded to the residence located at the address of 1335 Graham Place, on the report of a burglary in progress. I responded to the scene in marked patrol vehicle #19, with emergency lights and audible sirens activated. During our response, we were advised by dispatch that the actors had fled the area. Preliminary descriptions reported two actors, a male and a female, last seen heading north, on foot, in the direction of West Englewood Avenue.

I was the first officer on scene. As I was turning onto Graham Place, I observed a white Dodge Charger, traveling in the opposite direction, at what appeared to be a relatively high rate of speed.

| Officer of Record: | Date: | Other Reports Filed: | Reviewed By: |
|---------------------|----------|---|--------------|
| PO Kevin Florio 349 | 12/31/19 | MVA Arrest 3 DV DWI DWIQ Tow SD CI TRO SHA Prop. Video UOF Prst Supp 2 Juv Bias Prls 2 | jgarland |

Appendix C:

Municipal Records: Building Department



NOTICE AND ORDER OF PENALTY

Permit/Control #: 20191363

Date Issued: 2/1/2022

Violation #: V-22-0005

IDENTIFICATION

Work Site Location: 1335 GRAHAM PLACE TEANECK, NJ

Block: 4905 Lot: 22.01 Qualification Code: _____

Owner in Fee: 1335 GRAHAM PLACE LLC

Owner Address: 17C BULGER AVENUE NEW MILFORD NJ 07646

Agent/Contractor: RETURN ON INVESTMENT PROPERTIES LLC

Address: 17 BULGER AVENUE APT C NEW MILFORD NJ 07646

To: Owner Other:

Agent/Contractor

ACTION

On _____, you were found to be in violation of the State Uniform Construction Code Act and Regulations promulgated thereunder. A **Notice of Violation and Order to Terminate**, **Notice of Unsafe Structure**, **Notice of Imminent Hazard** was issued. Reinspection of the work site on _____

revealed the following violation(s) remain:

NJAC 5:23-2.23 Occupying a New or Altered Structure w/o CO

On _____, you were found to be in violation of the State Uniform Construction Code Act and Regulations promulgated thereunder, in that you **made a false or misleading written statement, or omitted required required information in an application or request for approval; or** **failed to obtain a construction permit; or** **failed to request required inspections; or** **allowed occupancy prior to receiving a certificate of occupancy.**

On _____, you were found to be in violation of the State Uniform Construction Code Act and Regulations promulgated thereunder. A **Stop Construction Order** was issued. Reinspection of the work site on _____ revealed a failure to comply with that **Stop Construction Order**.

PENALTY

Therefore, you are hereby **ORDERED** to pay a penalty in the amount of \$2,000.00 for each violation for a total penalty of \$2,000.00.

Further, take **NOTICE** that for each week day that any of the said violations remain outstanding after 3/3/2022 an additional penalty of \$500.00 per week day shall result

If you wish to contest this **ORDER**, you may request a hearing before the Construction Board of Appeals of the BERGEN COUNTY within 15 days of receipt of this **ORDER** as provided by N.J.A.C. 5:23 A-2.1. The Application of the Construction Board of Appeals may be used for this purpose.

Your application for appeal must be in writing, setting forth your name and address, the address of the building or site in question, the permit number, the specific sections of the Regulations in question, and the extent and nature of your reliance on them. You may include a brief statement setting forth your position and the nature of the relief sought by you. You may also append any documents that you consider useful

The fee for an appeal is \$50.00 and should be forwarded with your application to the Construction

Board of Appeals Office at: **BERGEN COUNTY CONSTRUCTION BOARD OF APPEALS
ONE BERGEN COUNTY PLAZA, FOURTH FLOOR
HACKENSACK, NJ 07601**

If you have any questions concerning this matter, please call: (201) 837-1600

NOTICE and ORDER of PENALTY: _____ Date: _____

Construction Official



CONSTRUCTION PERMIT

Date Issued 8/16/2019
 Control # 75086
 Permit # 20191363

IDENTIFICATION Block: 4905 Lot: 22.01 Qualifier _____
 Work Site Location: 1335 GRAHAM PLACE TEANECK, NJ Contractor RETURN ON INVESTMENT PROPERTIES LLC
 Address 17 BULGER AVENUE APT C NEW MILFORD NJ 07646
 Owner in Fee 1335 GRAHAM PLACE LLC
17C BULGER AVENUE NEW MILFORD NJ 07646 Telephone: (201) 390-8047
 Telephone: (201) 390-8047 Lic. No. or Bldrs. Reg. No. _____
 Federal Employee No. _____

Is hereby granted permission to perform the following work:

- BUILDING PLUMBING LEAD HAZARD ABATEMENT
 ELECTRICAL FIRE PROTECTION DEMOLITION
 ELEVATOR DEVICES ASBESTOS ABATEMENT (Subchapter 8 only) OTHER

DESCRIPTION OF WORK:

Additions and Alterations RE-BUILD EXISTING FIRST FLOOR, ADD NEW SECOND FLOOR
ADDITION, NEW FRONT AND REAR PORCHES, AND 2 SIDE NEW AC UNITS AS PER PLANS
DATED 05-15-2019 REVISED PAGE 7-3-19

Note: If construction does not commence within one (1) year of date of issuance, or if construction ceases for a period of six (6) months, this permit is void.

Estimated Cost of Work \$90,000

PAYMENTS (Office Use Only)

| | |
|------------------|---------------|
| Building | \$1,817 |
| Electrical | \$533 |
| Plumbing | \$860 |
| Fire Protection | \$90 |
| Elevator Devices | \$0 |
| Other | \$0.00 |
| DCA Training Fee | \$121 |
| CO Fee | |
| Other | \$100 |
| Total | \$3,521 |
| Check No. | 153 |
| Cash | \$0 |
| Credit | \$0 |
| Collected By | Susan Walters |

 Construction Official Date

U.C.C. F170
equiv (rev 1/04)

- 1 WHITE - INSPECTOR 2 CANARY - OFFICE 3 PINK - TAX ASSESSOR 4 GOLD - APPLICANT

REQUIRED INSPECTIONS

Construction work must be inspected in accordance with the State Uniform Construction Code Regulations N.J.A.C. 5:23-2.18. This agency will carry out such periodic inspections during the progress of work as are necessary to insure that the work installed conforms with the requirements of the Uniform Construction Code.

The owner or other responsible person in charge of work must notify this agency when work is ready for any required inspections specified below. Requests for inspections must be made at least 24 hours prior to the time the inspection is desired. Inspections will be performed within three business days of the time for which they are requested. The work must not proceed in a manner which will preclude the inspection until it has been made and approval granted.

- Required inspections for all subcodes for one- and two-family dwellings are as follows:
- The bottom of footing trenches before placement of footings, except that in cases of pile foundations, inspections shall be made in accordance with the requirements of the building subcode.
 - Foundations and all walls up to grade level prior to back filling.
 - All structural framing, connections, wall and roof sheathing and insulation; electrical rough wiring, panel and service installation; rough plumbing. The framing inspection shall take place after the rough electrical and plumbing inspections and after the installation of the heating, ventilation and /or air conditioning duct system. The insulation inspection shall be performed after all other subcode rough inspections and prior to the installation of any interior finish material.
 - Installation of all finished materials, sealings of exterior joints, plumbing piping, trim and fixtures; electrical wiring, devices and fixtures; mechanical systems equipment.

Additional required inspections for all subcodes of construction, for other than one- and two-family dwellings, are fire suppression systems, heat producing devices and Barrier Free subcode accessibility, if applicable.

- Required special inspections. The applicant by accepting the permit will be deemed to have consented to these requirements:
- A final inspection is required for each applicable subcode area before a final Certificate of Occupancy or Approval may be issued. The final inspections include the installation of all interior and exterior finish materials, sealing of exterior joints, mechanical system and other required equipment; electrical wiring, devices and fixtures; plumbing pipes, trim and fixtures; tests required by any provision of the adopted subcodes, Barrier Free accessibility, if applicable; and verification of compliance with NJAC 5:23-3.5, "Posting structures".
- A complete copy of released plans must be kept on the job site.

If you do not understand any of this information, please ask.



PERMIT UPDATE

Date Update Issued _____
 Control # C-21-0146
 Permit # 20191363+A

IDENTIFICATION Block: 4905 Lot: 22.01 Qualifier _____
 Work Site Location: 1335 GRAHAM PLACE TEANECK, NJ 07666 Contractor RETURN ON INVESTMENT PROPERTIES LLC
 Address 17 BULGER AVENUE APT C NEW MILFORD NJ 07646
 Owner in Fee 1335 GRAHAM PLACE LLC Telephone: (201) 390-8047
17C BULGER AVENUE NEW MILFORD NJ 07646 Lic. No. or Bldrs. Reg. No. _____
 Telephone: (201) 390-8047 Federal Employee No. _____

Is hereby granted permission to perform the following work:

- BUILDING PLUMBING LEAD HAZARD ABATEMENT
 ELECTRICAL FIRE PROTECTION DEMOLITION
 ELEVATOR DEVICES ASBESTOS ABATEMENT (Subchapter 8 only) OTHER

DESCRIPTION OF WORK:

CHANGE OF CONTRACTOR ELECTRIC AND FIRE, ADDITIONAL ELECTRIC FIXTURES,
GARAGE SUB PANEL 30 AMP

Note: If construction does not commence within one (1) year of date of issuance, or if construction ceases for a period of six (6) months, this permit is void.

Estimated Cost of Work \$2,000

PAYMENTS (Office Use Only)

| | |
|------------------|--------|
| Building | \$0 |
| Electrical | \$122 |
| Plumbing | \$0 |
| Fire Protection | \$20 |
| Elevator Devices | \$0 |
| Other | \$0.00 |
| DCA Training Fee | \$4 |
| CO Fee | |
| Other | \$0 |
| Total | \$146 |
| Check No. | |
| Cash | \$0 |
| Credit | \$0 |
| Collected By | |

Construction Official _____ Date _____

U.C.C. F170
equiv (rev 1/04)

- 1 WHITE - INSPECTOR 2 CANARY - OFFICE 3 PINK - TAX ASSESSOR 4 GOLD - APPLICANT

REQUIRED INSPECTIONS

Construction work must be inspected in accordance with the State Uniform Construction Code Regulations N.J.A.C. 5:23-2.18. This agency will carry out such periodic inspections during the progress of work as are necessary to insure that the work installed conforms with the requirements of the Uniform Construction Code.

The owner or other responsible person in charge of work must notify this agency when work is ready for any required inspections specified below. Requests for inspections must be made at least 24 hours prior to the time the inspection is desired. Inspections will be performed within three business days of the time for which they are requested. The work must not proceed in a manner which will preclude the inspection until it has been made and approval granted.

- Required inspections for all subcodes for one- and two-family dwellings are as follows:
1. The bottom of footing trenches before placement of footings, except that in cases of pile foundations, inspections shall be made in accordance with the requirements of the building subcode.
 2. Foundations and all walls up to grade level prior to back filling.
 3. All structural framing, connections, wall and roof sheathing and insulation; electrical rough wiring, panel and service installation; rough plumbing. The framing inspection shall take place after the rough electrical and plumbing inspections and after the installation of the heating, ventilation and for air conditioning duct system. The insulation inspection shall be performed after all other subcode rough inspections and prior to the installation of any interior finish material.
 4. Installation of all finished materials, sealings of exterior joints, plumbing piping, trim and fixtures; electrical wiring, devices and fixtures; mechanical systems equipment.

Additional required inspections for all subcodes of construction, for other than one- and two-family dwellings, are fire suppression systems, heat producing devices and Barrier Free subcode accessibility, if applicable.

Required special inspections. The applicant by accepting the permit will be deemed to have consented to these requirements:

A final inspection is required for each applicable subcode area before a final Certificate of Occupancy or Approval may be issued. The final inspections include the installation of all interior and exterior finish materials, sealing of exterior joints, mechanical system and other required equipment; electrical wiring, devices and fixtures; plumbing pipes, trim and fixtures; tests required by any provision of the adopted subcodes, Barrier Free accessibility, if applicable; and verification of compliance with NJAC 5:23-3.5, "Posting structures".

A complete copy of released plans must be kept on the job site.

If you do not understand any of this information, please ask.



PERMIT UPDATE

Date Update Issued _____
 Control # C-22-0220
 Permit # 20191363+B

IDENTIFICATION Block: 4905 Lot: 22.01 Qualifier _____
 Work Site Location: 1335 GRAHAM PLACE TEANECK, NJ Contractor RETURN ON INVESTMENT PROPERTIES LLC
 Address 17 BULGER AVENUE APT C NEW MILFORD NJ 07646
 Owner in Fee 1335 GRAHAM PLACE LLC
17C BULGER AVENUE NEW MILFORD NJ 07646 Telephone: (201) 390-8047
 Telephone: (201) 390-8047 Lic. No. or Bldrs. Reg. No. _____
 Federal Employee No. _____

Is hereby granted permission to perform the following work:

- BUILDING PLUMBING LEAD HAZARD ABATEMENT
 ELECTRICAL FIRE PROTECTION DEMOLITION
 ELEVATOR DEVICES ASBESTOS ABATEMENT (Subchapter 8 only) OTHER

DESCRIPTION OF WORK:

UPDATE TWO (2) HVAC UNITS
Additions and Alterations RE-BUILD EXISTING FIRST FLOOR, ADD NEW SECOND FLOOR
ADDITION, NEW FRONT AND REAR PORCHES, AND 2 SIDE NEW AC UNITS AS PER PLANS

Note: If construction does not commence within one (1) year of date of issuance, or if construction ceases for a period of six (6) months, this permit is void.

Estimated Cost of Work \$19,500

PAYMENTS (Office Use Only)

| | |
|------------------|---------|
| Building | \$544 |
| Electrical | \$324 |
| Plumbing | \$350 |
| Fire Protection | \$150 |
| Elevator Devices | \$0 |
| Other | \$0.00 |
| DCA Training Fee | \$37 |
| CO Fee | |
| Other | \$0 |
| Total | \$1,405 |
| Check No. | |
| Cash | \$0 |
| Credit | \$0 |
| Collected By | |

 Construction Official Date

U.C.C. F170
equiv (rev 1/04)

- 1 WHITE - INSPECTOR 2 CANARY - OFFICE 3 PINK - TAX ASSESSOR 4 GOLD - APPLICANT

REQUIRED INSPECTIONS

Construction work must be inspected in accordance with the State Uniform Construction Code Regulations N.J.A.C. 5:23-2.18. This agency will carry out such periodic inspections during the progress of work as are necessary to insure that the work installed conforms with the requirements of the Uniform Construction Code.

The owner or other responsible person in charge of work must notify this agency when work is ready for any required inspections specified below. Requests for inspections must be made at least 24 hours prior to the time the inspection is desired. Inspections will be performed within three business days of the time for which they are requested. The work must not proceed in a manner which will preclude the inspection until it has been made and approval granted.

- Required inspections for all subcodes for one- and two-family dwellings are as follows:
- The bottom of footing trenches before placement of footings, except that in cases of pile foundations, inspections shall be made in accordance with the requirements of the building subcode.
 - Foundations and all walls up to grade level prior to back filling.
 - All structural framing, connections, wall and roof sheathing and insulation; electrical rough wiring, panel and service installation; rough plumbing. The framing inspection shall take place after the rough electrical and plumbing inspections and after the installation of the heating, ventilation and/or air conditioning duct system. The insulation inspection shall be performed after all other subcode rough inspections and prior to the installation of any interior finish material.
 - Installation of all finished materials, sealings of exterior joints, plumbing piping, trim and fixtures; electrical wiring, devices and fixtures; mechanical systems equipment.

Additional required inspections for all subcodes of construction, for other than one- and two-family dwellings, are fire suppression systems, heat producing devices and Barrier Free subcode accessibility, if applicable.

- Required special inspections. The applicant by accepting the permit will be deemed to have consented to these requirements:
- A final inspection is required for each applicable subcode area before a final Certificate of Occupancy or Approval may be issued. The final inspections include the installation of all interior and exterior finish materials, sealing of exterior joints, mechanical system and other required equipment; electrical wiring, devices and fixtures; plumbing pipes, trim and fixtures; tests required by any provision of the adopted subcodes, Barrier Free accessibility, if applicable; and verification of compliance with NJAC 5:23-3.5, "Posting structures".
- A complete copy of released plans must be kept on the job site.

If you do not understand any of this information, please ask.



CONSTRUCTION PERMIT

Date Issued 11/17/2020
 Control # C-20-1543
 Permit # 20201385

IDENTIFICATION Block: 4905 Lot: 22.01 Qualifier _____
 Work Site Location: 1335 GRAHAM PL TEANECK, NJ 07666 Contractor PROFESSIONAL RADON SYSTEM
 Address 27 KRAMER DRIVE PARAMUS NJ 07652
 Owner in Fee 1335 GRAHAM PLACE LLC
1335 GRAHAM PL TEANECK NJ 07666 Telephone: (201) 652-0072
 Telephone: (201) 286-7133 Lic. No. or Bids. Reg. No. MIB90026
 Federal Employee No. 223078961

Is hereby granted permission to perform the following work:

- BUILDING PLUMBING LEAD HAZARD ABATEMENT
 ELECTRICAL FIRE PROTECTION DEMOLITION
 ELEVATOR DEVICES ASBESTOS ABATEMENT (Subchapter 8 only) OTHER

DESCRIPTION OF WORK:

RADON SYSTEM

Note: If construction does not commence within one (1) year of date of issuance, or if construction ceases for a period of six (6) months, this permit is void.
Estimated Cost of Work \$1,300

PAYMENTS (Office Use Only)

| | |
|------------------|---------------|
| Building | \$80 |
| Electrical | \$80 |
| Plumbing | \$0 |
| Fire Protection | \$0 |
| Elevator Devices | \$0 |
| Other | \$0.00 |
| DCA Training Fee | \$3 |
| CO Fee | |
| Other | \$0 |
| Total | \$163 |
| Check No. | 10390 |
| Cash | \$0 |
| Credit | \$0 |
| Collected By | Cathy Puglisi |

Construction Official _____ Date _____

U.C.C. F170
equiv (rev 1/04)

- 1 WHITE - INSPECTOR 2 CANARY - OFFICE 3 PINK - TAX ASSESSOR 4 GOLD - APPLICANT

REQUIRED INSPECTIONS

Construction work must be inspected in accordance with the State Uniform Construction Code Regulations N.J.A.C. 5:23-2.18. This agency will carry out such periodic inspections during the progress of work as are necessary to insure that the work installed conforms with the requirements of the Uniform Construction Code.

The owner or other responsible person in charge of work must notify this agency when work is ready for any required inspections specified below. Requests for inspections must be made at least 24 hours prior to the time the inspection is desired. Inspections will be performed within three business days of the time for which they are requested. The work must not proceed in a manner which will preclude the inspection until it has been made and approval granted.

- Required inspections for all subcodes for one- and two-family dwellings are as follows:
- The bottom of footing trenches before placement of footings, except that in cases of pile foundations, inspections shall be made in accordance with the requirements of the building subcode.
 - Foundations and all walls up to grade level prior to back filling.
 - All structural framing, connections, wall and roof sheathing and insulation; electrical rough wiring, panel and service installation; rough plumbing. The framing inspection shall take place after the rough electrical and plumbing inspections and after the installation of the heating, ventilation and /or air conditioning duct system. The insulation inspection shall be performed after all other subcode rough inspections and prior to the installation of any interior finish material.
 - Installation of all finished materials, sealings of exterior joints, plumbing piping, trim and fixtures; electrical wiring, devices and fixtures; mechanical systems equipment.

Additional required inspections for all subcodes of construction, for other than one- and two-family dwellings, are fire suppression systems, heat producing devices and Barrier Free subcode accessibility, if applicable.

- Required special inspections. The applicant by accepting the permit will be deemed to have consented to these requirements:
- A final inspection is required for each applicable subcode area before a final Certificate of Occupancy or Approval may be issued. The final inspections include the installation of all interior and exterior finish materials, sealing of exterior joints, mechanical system and other required equipment; electrical wiring, devices and fixtures; plumbing pipes, trim and fixtures; tests required by any provision of the adopted subcodes, Barrier Free accessibility, if applicable; and verification of compliance with NJAC 5:23-3.5, "Posting structures".

- A complete copy of released plans must be kept on the job site.

If you do not understand any of this information, please ask.



CONSTRUCTION PERMIT

Date Issued 9/12/2019
 Control # 75660
 Permit # 20191514

IDENTIFICATION Block: 4905 Lot: 21 Qualifier _____
 Work Site Location: 43 ORCHARD STREET TEANECK, NJ Contractor LOMBARDO ENVIROMENTAL CO
 Address 32 BUSHES LANE/P.O BOX 62 ELMWOOD PARK NJ
 Owner in Fee MELISSA HOWARD Telephone: (201) 796-3390
43 ORCHARD STREET TEANECK NJ 07666 Lic. No. or Bldrs. Reg. No. _____
 Telephone: (201) 796-3390 Federal Employee No. 22-3548562

Is hereby granted permission to perform the following work:

- BUILDING PLUMBING LEAD HAZARD ABATEMENT
 ELECTRICAL FIRE PROTECTION DEMOLITION
 ELEVATOR DEVICES ASBESTOS ABATEMENT (Subchapter 8 only) OTHER

DESCRIPTION OF WORK:

Tank Removal 550 GAL UST FROM BACKYARD

Note: If construction does not commence within one (1) year of date of issuance, or if construction ceases for a period of six (6) months, this permit is void.

Estimated Cost of Work \$1,500

PAYMENTS (Office Use Only)

| | | |
|------------------|-------|--------|
| Building | _____ | \$0 |
| Electrical | _____ | \$0 |
| Plumbing | _____ | \$0 |
| Fire Protection | _____ | \$200 |
| Elevator Devices | _____ | \$0 |
| Other | _____ | \$0.00 |
| DCA Training Fee | _____ | \$0 |
| CO Fee | _____ | _____ |
| Other | _____ | \$0 |
| Total | _____ | \$200 |
| Check No. | _____ | 54129 |
| Cash | _____ | \$0 |
| Credit | _____ | \$0 |
| Collected By | _____ | CP |

Construction Official _____ Date _____

U.C.C. F170
equiv (rev 1/04)

- 1 WHITE - INSPECTOR 2 CANARY - OFFICE 3 PINK - TAX ASSESSOR 4 GOLD - APPLICANT

REQUIRED INSPECTIONS

Construction work must be inspected in accordance with the State Uniform Construction Code Regulations N.J.A.C. 5:23-2.18. This agency will carry out such periodic inspections during the progress of work as are necessary to insure that the work installed conforms with the requirements of the Uniform Construction Code.

The owner or other responsible person in charge of work must notify this agency when work is ready for any required inspections specified below. Requests for inspections must be made at least 24 hours prior to the time the inspection is desired. Inspections will be performed within three business days of the time for which they are requested. The work must not proceed in a manner which will preclude the inspection until it has been made and approval granted.

- Required inspections for all subcodes for one- and two-family dwellings are as follows:
- The bottom of footing trenches before placement of footings, except that in cases of pile foundations, inspections shall be made in accordance with the requirements of the building subcode.
 - Foundations and all walls up to grade level prior to back filling.
 - All structural framing, connections, wall and roof sheathing and insulation; electrical rough wiring, panel and service installation; rough plumbing. The framing inspection shall take place after the rough electrical and plumbing inspections and after the installation of the heating, ventilation and/or air conditioning duct system. The insulation inspection shall be performed after all other subcode rough inspections and prior to the installation of any interior finish material.
 - Installation of all finished materials, sealings of exterior joints, plumbing piping, trim and fixtures; electrical wiring, devices and fixtures; mechanical systems equipment.

Additional required inspections for all subcodes of construction, for other than one- and two-family dwellings, are fire suppression systems, heat producing devices and Barrier Free subcode accessibility, if applicable.

Required special inspections. The applicant by accepting the permit will be deemed to have consented to these requirements:

A final inspection is required for each applicable subcode area before a final Certificate of Occupancy or Approval may be issued. The final inspections include the installation of all interior and exterior finish materials, sealing of exterior joints, mechanical system and other required equipment; electrical wiring, devices and fixtures; plumbing pipes, trim and fixtures; tests required by any provision of the adopted subcodes, Barrier Free accessibility, if applicable; and verification of compliance with NJAC 5:23-3.5, "Posting structures".

A complete copy of released plans must be kept on the job site.

If you do not understand any of this information, please ask.



CONSTRUCTION PERMIT

Date Issued 8/27/2021
 Control # C-21-1700
 Permit # 20211386

IDENTIFICATION Block: 4905 Lot: 18 Qualifier _____
 Work Site Location: 23 ORCHARD ST TEANECK, NJ 07666 Contractor AIM TANK SERVICES
 Address 166 RYERSON AVE WAYNE NJ 07470
 Owner in Fee LONDON JAN
23 ORCHARD ST TEANECK NJ 07666 Telephone: (973) 633-5275
 Telephone: (201) 390-3308 Lic. No. or Bldrs. Reg. No. US00621
 Federal Employee No. 222650740

Is hereby granted permission to perform the following work:

- BUILDING PLUMBING LEAD HAZARD ABATEMENT
 ELECTRICAL FIRE PROTECTION DEMOLITION
 ELEVATOR DEVICES ASBESTOS ABATEMENT (Subchapter 8 only) OTHER

DESCRIPTION OF WORK:

TANK REMOVAL 275 AST

Note: If construction does not commence within one (1) year of date of issuance, or if construction ceases for a period of six (6) months, this permit is void.

Estimated Cost of Work \$1,375

| PAYMENTS (Office Use Only) | |
|----------------------------|---------------|
| Building | \$0 |
| Electrical | \$0 |
| Plumbing | \$0 |
| Fire Protection | \$200 |
| Elevator Devices | \$0 |
| Other | \$0.00 |
| DCA Training Fee | \$0 |
| CO Fee | |
| Other | \$0 |
| Total | \$200 |
| Check No. | 54151 |
| Cash | \$0 |
| Credit | \$0 |
| Collected By | Susan Walters |

 Construction Official Date

U.C.C. F170
equiv (rev 1/04)

- 1 WHITE - INSPECTOR 2 CANARY - OFFICE 3 PINK - TAX ASSESSOR 4 GOLD - APPLICANT

REQUIRED INSPECTIONS

Construction work must be inspected in accordance with the State Uniform Construction Code Regulations N.J.A.C. 5:23-2.18. This agency will carry out such periodic inspections during the progress of work as are necessary to insure that the work installed conforms with the requirements of the Uniform Construction Code.

The owner or other responsible person in charge of work must notify this agency when work is ready for any required inspections specified below. Requests for inspections must be made at least 24 hours prior to the time the inspection is desired. Inspections will be performed within three business days of the time for which they are requested. The work must not proceed in a manner which will preclude the inspection until it has been made and approval granted.

- Required inspections for all subcodes for one- and two-family dwellings are as follows:
1. The bottom of footing trenches before placement of footings, except that in cases of pile foundations, inspections shall be made in accordance with the requirements of the building subcode.
 2. Foundations and all walls up to grade level prior to back filling.
 3. All structural framing, connections, wall and roof sheathing and insulation; electrical rough wiring, panel and service installation; rough plumbing. The framing inspection shall take place after the rough electrical and plumbing inspections and after the installation of the heating, ventilation and /or air conditioning duct system. The insulation inspection shall be performed after all other subcode rough inspections and prior to the installation of any interior finish material.
 4. Installation of all finished materials, sealings of exterior joints, plumbing piping, trim and fixtures; electrical wiring, devices and fixtures; mechanical systems equipment.

Additional required inspections for all subcodes of construction, for other than one- and two-family dwellings, are fire suppression systems, heat producing devices and Barrier Free subcode accessibility, if applicable.

- Required special inspections. The applicant by accepting the permit will be deemed to have consented to these requirements:
- A final inspection is required for each applicable subcode area before a final Certificate of Occupancy or Approval may be issued. The final inspections include the installation of all interior and exterior finish materials, sealing of exterior joints, mechanical system and other required equipment; electrical wiring, devices and fixtures; plumbing pipes, trim and fixtures; tests required by any provision of the adopted subcodes, Barrier Free accessibility, if applicable; and verification of compliance with NJAC 5:23-3.5, "Posting structures".
- A complete copy of released plans must be kept on the job site.

If you do not understand any of this information, please ask.



CONSTRUCTION PERMIT

Date Issued 2/25/2022
 Control # C-22-0334
 Permit # 20220283

IDENTIFICATION Block: 4905 Lot: 18 Qualifier _____
 Work Site Location: 23 ORCHARD ST TEANECK, NJ 07666 Contractor COUNTRY SIDE CHIMNEY
 Address 23 AUSTIN STREET RIDGEFIELD PARK NJ 07660
 Owner in Fee LONDON JAN
23 ORCHARD ST TEANECK NJ 07666 Telephone: (201) 931-1222
 Telephone: (201) 390-3308 Lic. No. or Bldrs. Reg. No. 13VH01308300
 Federal Employee No. 202485939

Is hereby granted permission to perform the following work:

- BUILDING PLUMBING LEAD HAZARD ABATEMENT
 ELECTRICAL FIRE PROTECTION DEMOLITION
 ELEVATOR DEVICES ASBESTOS ABATEMENT (Subchapter 8 only) OTHER

DESCRIPTION OF WORK:

CHIMNEY LINER

Note: If construction does not commence within one (1) year of date of issuance, or if construction ceases for a period of six (6) months, this permit is void.

Estimated Cost of Work \$3,000

PAYMENTS (Office Use Only)

| | |
|------------------|-----------------|
| Building | \$0 |
| Electrical | \$0 |
| Plumbing | \$0 |
| Fire Protection | \$0 |
| Elevator Devices | \$0 |
| Other | \$100.00 |
| DCA Training Fee | \$6 |
| CO Fee | |
| Other | \$0 |
| Total | \$106 |
| Check No. | 5455 |
| Cash | \$0 |
| Credit | \$0 |
| Collected By | Sharly Trinidad |

Construction Official _____ Date _____

U.C.C. F170
equiv (rev 1/04)

- 1 WHITE - INSPECTOR 2 CANARY - OFFICE 3 PINK - TAX ASSESSOR 4 GOLD - APPLICANT

REQUIRED INSPECTIONS

Construction work must be inspected in accordance with the State Uniform Construction Code Regulations N.J.A.C. 5:23-2.18. This agency will carry out such periodic inspections during the progress of work as are necessary to insure that the work installed conforms with the requirements of the Uniform Construction Code.

The owner or other responsible person in charge of work must notify this agency when work is ready for any required inspections specified below. Requests for inspections must be made at least 24 hours prior to the time the inspection is desired. Inspections will be performed within three business days of the time for which they are requested. The work must not proceed in a manner which will preclude the inspection until it has been made and approval granted.

- Required inspections for all subcodes for one- and two-family dwellings are as follows:
- The bottom of footing trenches before placement of footings, except that in cases of pile foundations, inspections shall be made in accordance with the requirements of the building subcode.
 - Foundations and all walls up to grade level prior to back filling.
 - All structural framing, connections, wall and roof sheathing and insulation; electrical rough wiring, panel and service installation; rough plumbing. The framing inspection shall take place after the rough electrical and plumbing inspections and after the installation of the heating, ventilation and /or air conditioning duct system. The insulation inspection shall be performed after all other subcode rough inspections and prior to the installation of any interior finish material.
 - Installation of all finished materials, sealings of exterior joints, plumbing piping, trim and fixtures; electrical wiring, devices and fixtures; mechanical systems equipment.

Additional required inspections for all subcodes of construction, for other than one- and two-family dwellings, are fire suppression systems, heat producing devices and Barrier Free subcode accessibility, if applicable.

- Required special inspections. The applicant by accepting the permit will be deemed to have consented to these requirements:

- A final inspection is required for each applicable subcode area before a final Certificate of Occupancy or Approval may be issued. The final inspections include the installation of all interior and exterior finish materials, sealing of exterior joints, mechanical system and other required equipment; electrical wiring, devices and fixtures; plumbing pipes, trim and fixtures; tests required by any provision of the adopted subcodes, Barrier Free accessibility, if applicable; and verification of compliance with NJAC 5:23-3.5, "Posting structures".

- A complete copy of released plans must be kept on the job site.

If you do not understand any of this information, please ask.



CONSTRUCTION PERMIT

Date Issued 3/11/2022
 Control # C-21-0530
 Permit # 20220342

IDENTIFICATION Block: 4905 Lot: 18 Qualifier _____
 Work Site Location: 23 ORCHARD ST Teaneck Township, NJ Contractor O'NEILL CONTRACTING INC.
 Address 232 NORTH WASHINGTON AVE BERGENFIELD NJ
 Owner in Fee LONDON JAN Telephone: (201) 385-6727
23 ORCHARD ST TEANECK NJ 07666 Lic. No. or Bids. Reg. No. _____
 Telephone: (201) 390-3308 Federal Employee No. 223626325

Is hereby granted permission to perform the following work:

- BUILDING PLUMBING LEAD HAZARD ABATEMENT
 ELECTRICAL FIRE PROTECTION DEMOLITION
 ELEVATOR DEVICES ASBESTOS ABATEMENT (Subchapter 8 only) OTHER

DESCRIPTION OF WORK:

REPLACEMENT BOILER

Note: If construction does not commence within one (1) year of date of issuance, or if construction ceases for a period of six (6) months, this permit is void.
 Estimated Cost of Work \$9,169

PAYMENTS (Office Use Only)

| | |
|------------------|-----------------|
| Building | \$0 |
| Electrical | \$80 |
| Plumbing | \$0 |
| Fire Protection | \$0 |
| Elevator Devices | \$0 |
| Other | \$100.00 |
| DCA Training Fee | \$18 |
| CO Fee | |
| Other | \$0 |
| Total | \$198 |
| Check No. | 29771 |
| Cash | \$0 |
| Credit | \$0 |
| Collected By | Sharly Trinidad |

 Construction Official Date

U.C.C. F170
equiv (rev 1/04)

- 1 WHITE - INSPECTOR 2 CANARY - OFFICE 3 PINK - TAX ASSESSOR 4 GOLD - APPLICANT

REQUIRED INSPECTIONS

Construction work must be inspected in accordance with the State Uniform Construction Code Regulations N.J.A.C. 5:23-2.18. This agency will carry out such periodic inspections during the progress of work as are necessary to insure that the work installed conforms with the requirements of the Uniform Construction Code.

The owner or other responsible person in charge of work must notify this agency when work is ready for any required inspections specified below. Requests for inspections must be made at least 24 hours prior to the time the inspection is desired. Inspections will be performed within three business days of the time for which they are requested. The work must not proceed in a manner which will preclude the inspection until it has been made and approval granted.

- Required inspections for all subcodes for one- and two-family dwellings are as follows:
- The bottom of footing trenches before placement of footings, except that in cases of pile foundations, inspections shall be made in accordance with the requirements of the building subcode.
 - Foundations and all walls up to grade level prior to back filling.
 - All structural framing, connections, wall and roof sheathing and insulation; electrical rough wiring, panel and service installation; rough plumbing. The framing inspection shall take place after the rough electrical and plumbing inspections and after the installation of the heating, ventilation and /or air conditioning duct system. The insulation inspection shall be performed after all other subcode rough inspections and prior to the installation of any interior finish material.
 - Installation of all finished materials, sealings of exterior joints, plumbing piping, trim and fixtures; electrical wiring, devices and fixtures; mechanical systems equipment.

Additional required inspections for all subcodes of construction, for other than one- and two-family dwellings, are fire suppression systems, heat producing devices and Barrier Free subcode accessibility, if applicable.

- Required special inspections. The applicant by accepting the permit will be deemed to have consented to these requirements:
- A final inspection is required for each applicable subcode area before a final Certificate of Occupancy or Approval may be issued. The final inspections include the installation of all interior and exterior finish materials, sealing of exterior joints, mechanical system and other required equipment; electrical wiring, devices and fixtures; plumbing pipes, trim and fixtures; tests required by any provision of the adopted subcodes, Barrier Free accessibility, if applicable; and verification of compliance with NJAC 5:23-3.5, "Posting structures".
- A complete copy of released plans must be kept on the job site.

If you do not understand any of this information, please ask.



CONSTRUCTION PERMIT

Date Issued 12/10/2019
 Control # 74514
 Permit # 20192012

IDENTIFICATION Block: 4905 Lot: 13 Qualifier _____
 Work Site Location: 1348 TEANECK RD 1348-1352 Teaneck Contractor MASSOLA CONSTRUCTION
 Township, NJ Address 15 STUART LANE WAYNE NJ 07470
 Owner in Fee SATISH BIDJA Telephone: (973) 633-0609
245 TERRACE AVENUE JERSEY CITY NJ 07666 Lic. No. or Bldrs. Reg. No. _____
 Telephone: (201) 798-7678 Federal Employee. No. 223651124

Is hereby granted permission to perform the following work:

- BUILDING PLUMBING LEAD HAZARD ABATEMENT
 ELECTRICAL FIRE PROTECTION DEMOLITION
 ELEVATOR DEVICES ASBESTOS ABATEMENT (Subchapter 8 only) OTHER

DESCRIPTION OF WORK:

ESTABLISH A FAST FOOD RESTAURANT "BLIMPIES".
RESOLUTION ATTACHED TO PLANS,
18 SEATS MAX

Note: If construction does not commence within one (1) year of date of issuance, or if construction ceases for a period of six (6) months, this permit is void.
Estimated Cost of Work \$157,500

| PAYMENTS (Office Use Only) | |
|----------------------------|---------------|
| Building | \$2,780 |
| Electrical | \$761 |
| Plumbing | \$1,040 |
| Fire Protection | \$90 |
| Elevator Devices | \$0 |
| Other | \$0.00 |
| DCA Training Fee | \$299 |
| CO Fee | \$467.00 |
| Other | \$0 |
| Total | \$5,437 |
| Check No. | 0011 |
| Cash | \$0 |
| Credit | \$0 |
| Collected By | Susan Walters |

 Construction Official Date

U.C.C. F170
 equiv (rev 1/04)

- 1 WHITE - INSPECTOR 2 CANARY - OFFICE 3 PINK - TAX ASSESSOR 4 GOLD - APPLICANT

REQUIRED INSPECTIONS

Construction work must be inspected in accordance with the State Uniform Construction Code Regulations N.J.A.C. 5:23-2.18. This agency will carry out such periodic inspections during the progress of work as are necessary to insure that the work installed conforms with the requirements of the Uniform Construction Code.

The owner or other responsible person in charge of work must notify this agency when work is ready for any required inspections specified below. Requests for inspections must be made at least 24 hours prior to the time the inspection is desired. Inspections will be performed within three business days of the time for which they are requested. The work must not proceed in a manner which will preclude the inspection until it has been made and approval granted.

- Required inspections for all subcodes for one- and two-family dwellings are as follows:
1. The bottom of footing trenches before placement of footings, except that in cases of pile foundations, inspections shall be made in accordance with the requirements of the building subcode.
 2. Foundations and all walls up to grade level prior to back filling.
 3. All structural framing, connections, wall and roof sheathing and insulation; electrical rough wiring, panel and service installation; rough plumbing. The framing inspection shall take place after the rough electrical and plumbing inspections and after the installation of the heating, ventilation and /or air conditioning duct system. The insulation inspection shall be performed after all other subcode rough inspections and prior to the installation of any interior finish material.
 4. Installation of all finished materials, sealings of exterior joints, plumbing piping, trim and fixtures; electrical wiring, devices and fixtures; mechanical systems equipment.

Additional required inspections for all subcodes of construction, for other than one- and two-family dwellings, are fire suppression systems, heat producing devices and Barrier Free subcode accessibility, if applicable.

- Required special inspections. The applicant by accepting the permit will be deemed to have consented to these requirements:
- A final inspection is required for each applicable subcode area before a final Certificate of Occupancy or Approval may be issued. The final inspections include the installation of all interior and exterior finish materials, sealing of exterior joints, mechanical system and other required equipment; electrical wiring, devices and fixtures; plumbing pipes, trim and fixtures; tests required by any provision of the adopted subcodes, Barrier Free accessibility, if applicable; and verification of compliance with NJAC 5:23-3.5, "Posting structures".
- A complete copy of released plans must be kept on the job site.

If you do not understand any of this information, please ask.



CONSTRUCTION PERMIT

Date Issued 12/10/2019
 Control # 76036
 Permit # 20192012+A

IDENTIFICATION Block: 4905 Lot: 13 Qualifier _____
 Work Site Location: 1348-1352 TEANECK RD Teaneck Township, NJ Contractor MASSOLA CONSTRUCTION
 Address 15 STUART LANE WAYNE NJ 07470
 Owner in Fee NEEL BIDGA
1348 TEANECK ROAD TEANECK NJ 07666 Telephone: (973) 633-0609
 Telephone: (201) 706-0266 Lic. No. or Bldrs. Reg. No. _____
 Federal Employee No. 223651124

Is hereby granted permission to perform the following work:

- BUILDING PLUMBING LEAD HAZARD ABATEMENT
 ELECTRICAL FIRE PROTECTION DEMOLITION
 ELEVATOR DEVICES ASBESTOS ABATEMENT (Subchapter 8 only) OTHER

DESCRIPTION OF WORK:

HVAC TWO (2) UNITS ROOFTOP

Note: If construction does not commence within one (1) year of date of issuance, or if construction ceases for a period of six (6) months, this permit is void.

Estimated Cost of Work \$8,500

PAYMENTS (Office Use Only)

| | | |
|------------------|-------|---------------|
| Building | _____ | \$0 |
| Electrical | _____ | \$0 |
| Plumbing | _____ | \$450 |
| Fire Protection | _____ | \$180 |
| Elevator Devices | _____ | \$0 |
| Other | _____ | \$0.00 |
| DCA Training Fee | _____ | \$16 |
| CO Fee | _____ | |
| Other | _____ | \$0 |
| Total | _____ | \$646 |
| Check No. | _____ | 0011 |
| Cash | _____ | \$0 |
| Credit | _____ | \$0 |
| Collected By | _____ | Susan Walters |

 Construction Official Date

U.C.C. F170
 equiv (rev 1/04)

- 1 WHITE - INSPECTOR 2 CANARY - OFFICE 3 PINK - TAX ASSESSOR 4 GOLD - APPLICANT

REQUIRED INSPECTIONS

Construction work must be inspected in accordance with the State Uniform Construction Code Regulations N.J.A.C. 5:23-2.18. This agency will carry out such periodic inspections during the progress of work as are necessary to insure that the work installed conforms with the requirements of the Uniform Construction Code.

The owner or other responsible person in charge of work must notify this agency when work is ready for any required inspections specified below. Requests for inspections must be made at least 24 hours prior to the time the inspection is desired. Inspections will be performed within three business days of the time for which they are requested. The work must not proceed in a manner which will preclude the inspection until it has been made and approval granted.

- Required inspections for all subcodes for one- and two-family dwellings are as follows:
1. The bottom of footing trenches before placement of footings, except that in cases of pile foundations, inspections shall be made in accordance with the requirements of the building subcode.
 2. Foundations and all walls up to grade level prior to back filling.
 3. All structural framing, connections, wall and roof sheathing and insulation; electrical rough wiring, panel and service installation; rough plumbing. The framing inspection shall take place after the rough electrical and plumbing inspections and after the installation of the heating, ventilation and /or air conditioning duct system. The insulation inspection shall be performed after all other subcode rough inspections and prior to the installation of any interior finish material.
 4. Installation of all finished materials, sealings of exterior joints, plumbing piping, trim and fixtures; electrical wiring, devices and fixtures; mechanical systems equipment.

Additional required inspections for all subcodes of construction, for other than one- and two-family dwellings, are fire suppression systems, heat producing devices and Barrier Free subcode accessibility, if applicable.

- Required special inspections. The applicant by accepting the permit will be deemed to have consented to these requirements:
- A final inspection is required for each applicable subcode area before a final Certificate of Occupancy or Approval may be issued. The final inspections include the installation of all interior and exterior finish materials, sealing of exterior joints, mechanical system and other required equipment; electrical wiring, devices and fixtures; plumbing pipes, trim and fixtures; tests required by any provision of the adopted subcodes, Barrier Free accessibility, if applicable; and verification of compliance with NJAC 5:23-3.5, "Posting structures".

- A complete copy of released plans must be kept on the job site.

If you do not understand any of this information, please ask.



PERMIT UPDATE

Date Update Issued 7/29/2020
 Control # C-20-0760
 Permit # 20192012+B

IDENTIFICATION Block: 4905 Lot: 13 Qualifier _____
 Work Site Location: 1348 TEANECK RD 1348-1352 Teaneck Contractor MASSOLA CONSTRUCTION
 Township, NJ Address 15 STUART LANE WAYNE NJ 07470
 Owner in Fee SATISH BIDJA Telephone: (973) 633-0609
245 TERRACE AVENUE JERSEY CITY NJ 07666 Lic. No. or Bldrs. Reg. No. _____
 Telephone: (201) 798-7678 Federal Employee. No. 223651124

Is hereby granted permission to perform the following work:

- BUILDING PLUMBING LEAD HAZARD ABATEMENT
 ELECTRICAL FIRE PROTECTION DEMOLITION
 ELEVATOR DEVICES ASBESTOS ABATEMENT (Subchapter 8 only) OTHER

DESCRIPTION OF WORK:

COMMERCIAL BACKFLOW PREVENTER

Note: If construction does not commence within one (1) year of date of issuance, or if construction ceases for a period of six (6) months, this permit is void.

Estimated Cost of Work \$700

| PAYMENTS (Office Use Only) | |
|----------------------------|---------------|
| Building | \$0 |
| Electrical | \$0 |
| Plumbing | \$100 |
| Fire Protection | \$0 |
| Elevator Devices | \$0 |
| Other | \$0.00 |
| DCA Training Fee | \$1 |
| CO Fee | |
| Other | \$0 |
| Total | \$101 |
| Check No. | |
| Cash | \$101 |
| Credit | \$0 |
| Collected By | Susan Walters |

 Construction Official Date

U.C.C. F170
equiv (rev 1/04)

- 1 WHITE - INSPECTOR 2 CANARY - OFFICE 3 PINK - TAX ASSESSOR 4 GOLD - APPLICANT

REQUIRED INSPECTIONS

Construction work must be inspected in accordance with the State Uniform Construction Code Regulations N.J.A.C. 5:23-2.18. This agency will carry out such periodic inspections during the progress of work as are necessary to insure that the work installed conforms with the requirements of the Uniform Construction Code.

The owner or other responsible person in charge of work must notify this agency when work is ready for any required inspections specified below. Requests for inspections must be made at least 24 hours prior to the time the inspection is desired. Inspections will be performed within three business days of the time for which they are requested. The work must not proceed in a manner which will preclude the inspection until it has been made and approval granted.

- Required inspections for all subcodes for one- and two-family dwellings are as follows:
- The bottom of footing trenches before placement of footings, except that in cases of pile foundations, inspections shall be made in accordance with the requirements of the building subcode.
 - Foundations and all walls up to grade level prior to back filling.
 - All structural framing, connections, wall and roof sheathing and insulation; electrical rough wiring, panel and service installation; rough plumbing. The framing inspection shall take place after the rough electrical and plumbing inspections and after the installation of the heating, ventilation and /or air conditioning duct system. The insulation inspection shall be performed after all other subcode rough inspections and prior to the installation of any interior finish material.
 - Installation of all finished materials, sealings of exterior joints, plumbing piping, trim and fixtures; electrical wiring, devices and fixtures; mechanical systems equipment.

Additional required inspections for all subcodes of construction, for other than one- and two-family dwellings, are fire suppression systems, heat producing devices and Barrier Free subcode accessibility, if applicable.

- Required special inspections. The applicant by accepting the permit will be deemed to have consented to these requirements:
- A final inspection is required for each applicable subcode area before a final Certificate of Occupancy or Approval may be issued. The final inspections include the installation of all interior and exterior finish materials, sealing of exterior joints, mechanical system and other required equipment; electrical wiring, devices and fixtures; plumbing pipes, trim and fixtures; tests required by any provision of the adopted subcodes, Barrier Free accessibility, if applicable; and verification of compliance with NJAC 5:23-3.5, "Posting structures".
- A complete copy of released plans must be kept on the job site.

If you do not understand any of this information, please ask.



Teaneck Township
TEANECK BUILDING DEPARTMENT
818 TEANECK ROAD
TEANECK, NJ 07666
(201) 837-1600

Certificate

Construction Code Division
(Certificate of Occupancy)

Date Issued 10/27/2020
Control Number 74514
Permit Number 20192012
Permit Issue Date 12/10/2019

Certificate Number 20192012

Identification

Block: 4905 Lot: 13 Qual: _____

Work Site Location: 1348 TEANECK RD 1348-1352 Teaneck Township, NJ

Owner in Fee: SATISH BIDIA

Owner Address: 245 TERRACE AVENUE JERSEY CITY NJ 07666

Telephone: (201) 798-7678

Contractor

MASSOLA CONSTRUCTION

Address 15 STUART LANE WAYNE NJ 07470

Telephone: (973) 633-0609 Fax: _____

License Number or Builders Registration Number: _____

Federal Emp. Number: 223651124

Certificate of Occupancy

This serves notice that said building or structure has been constructed in accordance with the New Jersey Uniform Construction Code and is approved for occupancy.

Certificate of Approval

This serves notice that the work completed has been constructed or installed in accordance with the New Jersey Uniform Construction Code and is approved. If the permit was issued for minor work, this certificate was based upon what was visible at the time of inspection.

Certificate of Continued Occupancy

This serves notice that based on a general inspection of the visible parts of the building there are no imminent hazards and the building is approved for continued occupancy.

Temporary Certificate of Compliance

The following conditions must be met no later than or the owner will be subject to fine or order to vacate:
This certificate has an expiration date of:
Conditions to be met:

U.C.C. F260 (rev. 08/06)

Home Warranty Number: _____

Type of Warranty Plan: State Private

Construction Classification: Type III Use Group: A-2

Maximum Occupancy Load: 49 Maximum Live Load: 0

Description of Work/Use:

ESTABLISH A FAST FOOD RESTAURANT "BLIMPIES".
RESOLUTION ATTACHED TO PLANS,
18 SEATS MAX

Certificate Comments:

Certificate of Clearance - Lead Abatement 5:17

This serves notice that based on written certification, lead abatement was performed as per NJACS:17 to the following extent.

Total removal of lead-based paint hazards in scope of work

Partial or limited time period (_____ years); see file

Certificate of Clearance - Asbestos Abatement

This serves notice that based on written certification, asbestos abatement was performed to the following extent.

Total removal of asbestos hazards in scope of work

Partial or limited time period (_____ years); see file

Certificate of Compliance

This serves notice that said potentially hazardous equipment has been installed and/or maintained in accordance with the New Jersey Uniform Construction Code and is approved for use until

Temporary Certificate of Occupancy

The following conditions must be met no later than: _____
or the owner will be subject to fine or order to vacate:
This certificate has an expiration date of: _____
Conditions to be met:

Check Number: 0011

Fee: \$467.00

Collected By: Susan Walters



CONSTRUCTION PERMIT

Date Issued 7/27/2020
 Control # C-20-0462
 Permit # 20200811

IDENTIFICATION Block: 4905 Lot: 13 Qualifier _____
 Work Site Location: 1348 TEANECK RD Teaneck Township, NJ Contractor AMEER SIGNS
 Address 506-A ROUTE 46 WEST GARFIELD NJ 07026
 Owner in Fee JALASAI LLC
1348 TEANECK ROAD TEANECK NJ 07666 Telephone: (973) 580-2592
 Telephone: (201) 706-2066 Lic. No. or Bldrs. Reg. No. _____
 Federal Employee. No. _____

Is hereby granted permission to perform the following work:

- BUILDING PLUMBING LEAD HAZARD ABATEMENT
 ELECTRICAL FIRE PROTECTION DEMOLITION
 ELEVATOR DEVICES ASBESTOS ABATEMENT (Subchapter 8 only) OTHER

DESCRIPTION OF WORK:

NEW BUSINESS SIGN BLIMPIES AS PER DOCUMENTS SUBMITTED THROUGH 04-06-2020.
PB APPROVED ON 06-11-2020.

Note: If construction does not commence within one (1) year of date of issuance, or if construction ceases for a period of six (6) months, this permit is void.

Estimated Cost of Work \$3,301

| PAYMENTS (Office Use Only) | |
|----------------------------|---------------|
| Building | \$80 |
| Electrical | \$80 |
| Plumbing | \$0 |
| Fire Protection | \$0 |
| Elevator Devices | \$0 |
| Other | \$0.00 |
| DCA Training Fee | \$7 |
| CO Fee | |
| Other | \$0 |
| Total | \$167 |
| Check No. | |
| Cash | \$167 |
| Credit | \$0 |
| Collected By | Susan Walters |

Construction Official _____ Date _____

U.C.C. F170
equiv (rev 1/04)

- 1 WHITE - INSPECTOR 2 CANARY - OFFICE 3 PINK - TAX ASSESSOR 4 GOLD - APPLICANT

REQUIRED INSPECTIONS

Construction work must be inspected in accordance with the State Uniform Construction Code Regulations N.J.A.C. 5:23-2.18. This agency will carry out such periodic inspections during the progress of work as are necessary to insure that the work installed conforms with the requirements of the Uniform Construction Code.

The owner or other responsible person in charge of work must notify this agency when work is ready for any required inspections specified below. Requests for inspections must be made at least 24 hours prior to the time the inspection is desired. Inspections will be performed within three business days of the time for which they are requested. The work must not proceed in a manner which will preclude the inspection until it has been made and approval granted.

- Required inspections for all subcodes for one- and two-family dwellings are as follows:
- The bottom of footing trenches before placement of footings, except that in cases of pile foundations, inspections shall be made in accordance with the requirements of the building subcode.
 - Foundations and all walls up to grade level prior to back filling.
 - All structural framing, connections, wall and roof sheathing and insulation; electrical rough wiring, panel and service installation; rough plumbing. The framing inspection shall take place after the rough electrical and plumbing inspections and after the installation of the heating, ventilation and /or air conditioning duct system. The insulation inspection shall be performed after all other subcode rough inspections and prior to the installation of any interior finish material.
 - Installation of all finished materials, sealings of exterior joints, plumbing piping, trim and fixtures; electrical wiring, devices and fixtures; mechanical systems equipment.

Additional required inspections for all subcodes of construction, for other than one- and two-family dwellings, are fire suppression systems, heat producing devices and Barrier Free subcode accessibility, if applicable.

- Required special inspections. The applicant by accepting the permit will be deemed to have consented to these requirements:
- A final inspection is required for each applicable subcode area before a final Certificate of Occupancy or Approval may be issued. The final inspections include the installation of all interior and exterior finish materials, sealing of exterior joints, mechanical system and other required equipment; electrical wiring, devices and fixtures; plumbing pipes, trim and fixtures; tests required by any provision of the adopted subcodes, Barrier Free accessibility, if applicable; and verification of compliance with NJAC 5:23-3.5, "Posting structures".
- A complete copy of released plans must be kept on the job site.

If you do not understand any of this information, please ask.



CONSTRUCTION PERMIT

Date Issued 2/26/2018
 Control # 70810
 Permit # 20180427

IDENTIFICATION Block: 4905 Lot: 11 Qualifier _____
 Work Site Location: 1360 TEANECK ROAD TEANECK, NJ Contractor KANG WON CONSTRUCTION
 Address 231-B 3RD STREET PALISADES PARK NJ 07650
 Owner in Fee JO HO JUNG
1360 TEANECK ROAD TEANECK NJ 07666 Telephone: (201) 833-0021
 Telephone: (201) 421-0588 Lic. No. or Bldrs. Reg. No. _____
 Federal Employee. No. _____

Is hereby granted permission to perform the following work:

- BUILDING PLUMBING LEAD HAZARD ABATEMENT
 ELECTRICAL FIRE PROTECTION DEMOLITION
 ELEVATOR DEVICES ASBESTOS ABATEMENT (Subchapter 8 only) OTHER

DESCRIPTION OF WORK:

Alterations REMOVE BLOCK STAIRS IN BASEMENT

Note: If construction does not commence within one (1) year of date of issuance, or if construction ceases for a period of six (6) months, this permit is void.
 Estimated Cost of Work \$500

| PAYMENTS (Office Use Only) | |
|----------------------------|--------|
| Building | \$75 |
| Electrical | \$0 |
| Plumbing | \$0 |
| Fire Protection | \$0 |
| Elevator Devices | \$0 |
| Other | \$0.00 |
| DCA Training Fee | \$1 |
| CO Fee | |
| Other | \$0 |
| Total | \$76 |
| Check No. | |
| Cash | \$76 |
| Credit | \$0 |
| Collected By | YT |

Construction Official _____ Date _____

U.C.C. F170
equiv (rev 1/04)

- 1 WHITE - INSPECTOR 2 CANARY - OFFICE 3 PINK - TAX ASSESSOR 4 GOLD - APPLICANT

REQUIRED INSPECTIONS

Construction work must be inspected in accordance with the State Uniform Construction Code Regulations N.J.A.C. 5:23-2.18. This agency will carry out such periodic inspections during the progress of work as are necessary to insure that the work installed conforms with the requirements of the Uniform Construction Code.

The owner or other responsible person in charge of work must notify this agency when work is ready for any required inspections specified below. Requests for inspections must be made at least 24 hours prior to the time the inspection is desired. Inspections will be performed within three business days of the time for which they are requested. The work must not proceed in a manner which will preclude the inspection until it has been made and approval granted.

- Required inspections for all subcodes for one- and two-family dwellings are as follows:
- The bottom of footing trenches before placement of footings, except that in cases of pile foundations, inspections shall be made in accordance with the requirements of the building subcode.
 - Foundations and all walls up to grade level prior to back filling.
 - All structural framing, connections, wall and roof sheathing and insulation; electrical rough wiring, panel and service installation; rough plumbing. The framing inspection shall take place after the rough electrical and plumbing inspections and after the installation of the heating, ventilation and /or air conditioning duct system. The insulation inspection shall be performed after all other subcode rough inspections and prior to the installation of any interior finish material.
 - Installation of all finished materials, sealings of exterior joints, plumbing piping, trim and fixtures; electrical wiring, devices and fixtures; mechanical systems equipment.

Additional required inspections for all subcodes of construction, for other than one- and two-family dwellings, are fire suppression systems, heat producing devices and Barrier Free subcode accessibility, if applicable.

- Required special inspections. The applicant by accepting the permit will be deemed to have consented to these requirements:
- A final inspection is required for each applicable subcode area before a final Certificate of Occupancy or Approval may be issued. The final inspections include the installation of all interior and exterior finish materials, sealing of exterior joints, mechanical system and other required equipment; electrical wiring, devices and fixtures; plumbing pipes, trim and fixtures; tests required by any provision of the adopted subcodes, Barrier Free accessibility, if applicable; and verification of compliance with NJAC 5:23-3.5, "Posting structures".

A complete copy of released plans must be kept on the job site.

If you do not understand any of this information, please ask.



CONSTRUCTION PERMIT

Date Issued 10/21/2020
 Control # C-20-1411
 Permit # 20201264

IDENTIFICATION Block: 4905 Lot: 10 Qualifier _____
 Work Site Location: 18 WEST ENGLEWOOD AVE TEANECK, NJ Contractor SILVER STAFF MAINTENANCE
07666 Address 126 CANTERBURY AVENUE NO. ARLINGTON NJ
 Owner in Fee PAVON, LUZ AMPARO 07031
18 WEST ENGLEWOOD AVE TEANECK NJ Telephone: (201) 914-0453
07666 Lic. No. or Bldrs. Reg. No. 13VH00845400 US488197
 Telephone: _____ Federal Employee. No. 223655918

Is hereby granted permission to perform the following work:

- BUILDING PLUMBING LEAD HAZARD ABATEMENT
 ELECTRICAL FIRE PROTECTION DEMOLITION
 ELEVATOR DEVICES ASBESTOS ABATEMENT (Subchapter 8 only) OTHER

DESCRIPTION OF WORK:

REMOVE 550 UST IN REAR OF PROPERTY

Note: If construction does not commence within one (1) year of date of issuance, or if construction ceases for a period of six (6) months, this permit is void.

Estimated Cost of Work \$1,950

PAYMENTS (Office Use Only)

| | |
|------------------|---------------|
| Building | \$0 |
| Electrical | \$0 |
| Plumbing | \$0 |
| Fire Protection | \$200 |
| Elevator Devices | \$0 |
| Other | \$0.00 |
| DCA Training Fee | \$0 |
| CO Fee | |
| Other | \$0 |
| Total | \$200 |
| Check No. | 3121 |
| Cash | \$0 |
| Credit | \$0 |
| Collected By | Susan Walters |

Construction Official _____

Date _____

U.C.C. F170
equiv (rev 1/04)

1 WHITE - INSPECTOR

2 CANARY - OFFICE

3 PINK - TAX ASSESSOR

4 GOLD - APPLICANT

REQUIRED INSPECTIONS

Construction work must be inspected in accordance with the State Uniform Construction Code Regulations N.J.A.C. 5:23-2.18. This agency will carry out such periodic inspections during the progress of work as are necessary to insure that the work installed conforms with the requirements of the Uniform Construction Code.

The owner or other responsible person in charge of work must notify this agency when work is ready for any required inspections specified below. Requests for inspections must be made at least 24 hours prior to the time the inspection is desired. Inspections will be performed within three business days of the time for which they are requested. The work must not proceed in a manner which will preclude the inspection until it has been made and approval granted.

Required inspections for all subcodes for one- and two-family dwellings are as follows:

- The bottom of footing trenches before placement of footings, except that in cases of pile foundations, inspections shall be made in accordance with the requirements of the building subcode.
- Foundations and all walls up to grade level prior to back filling.
- All structural framing, connections, wall and roof sheathing and insulation; electrical rough wiring, panel and service installation; rough plumbing. The framing inspection shall take place after the rough electrical and plumbing inspections and after the installation of the heating, ventilation and /or air conditioning duct system. The insulation inspection shall be performed after all other subcode rough inspections and prior to the installation of any interior finish material.
- Installation of all finished materials, sealings of exterior joints, plumbing piping, trim and fixtures; electrical wiring, devices and fixtures; mechanical systems equipment.

Additional required inspections for all subcodes of construction, for other than one- and two-family dwellings, are fire suppression systems, heat producing devices and Barrier Free subcode accessibility, if applicable.

Required special inspections. The applicant by accepting the permit will be deemed to have consented to these requirements:

A final inspection is required for each applicable subcode area before a final Certificate of Occupancy or Approval may be issued. The final inspections include the installation of all interior and exterior finish materials, sealing of exterior joints, mechanical system and other required equipment; electrical wiring, devices and fixtures; plumbing pipes, trim and fixtures; tests required by any provision of the adopted subcodes, Barrier Free accessibility, if applicable; and verification of compliance with NJAC 5:23-3.5, "Posting structures".

A complete copy of released plans must be kept on the job site.

If you do not understand any of this information, please ask.



CONSTRUCTION PERMIT

Date Issued 11/9/2018
 Control # 73074
 Permit # 20181926

IDENTIFICATION Block: 4905 Lot: 3 Qualifier _____
 Work Site Location: 54 W ENGLEWOOD AVENUE TEANECK, NJ Contractor MY HOME DESIGN STUDIO LLC
 Address 1372 TEANECK ROAD TEANECK NJ 07666
 Owner in Fee MOHAMMED SADIQUILLA
54 W ENGLEWOOD AVENUE TEANECK NJ Telephone: (201) 575-3701
07666 Lic. No. or Bldrs. Reg. No. _____
 Telephone: (201) 779-6824 Federal Employee. No. _____

Is hereby granted permission to perform the following work:

- BUILDING PLUMBING LEAD HAZARD ABATEMENT
 ELECTRICAL FIRE PROTECTION DEMOLITION
 ELEVATOR DEVICES ASBESTOS ABATEMENT (Subchapter 8 only) OTHER

DESCRIPTION OF WORK:

Roofing REPLACE PLYWOOD ON ROOF/GARAGE ROOF AND FLOOR BOARD ON PORCH

Note: If construction does not commence within one (1) year of date of issuance, or if construction ceases for a period of six (6) months, this permit is void.
 Estimated Cost of Work \$5,000

| PAYMENTS (Office Use Only) | |
|----------------------------|--------|
| Building | \$170 |
| Electrical | \$0 |
| Plumbing | \$0 |
| Fire Protection | \$0 |
| Elevator Devices | \$0 |
| Other | \$0.00 |
| DCA Training Fee | \$10 |
| CO Fee | |
| Other | \$0 |
| Total | \$180 |
| Check No. | 2248 |
| Cash | \$0 |
| Credit | \$0 |
| Collected By | CP |

Construction Official _____ Date _____

U.C.C. F170
 equiv (rev 1/04)

- 1 WHITE - INSPECTOR 2 CANARY - OFFICE 3 PINK - TAX ASSESSOR 4 GOLD - APPLICANT

REQUIRED INSPECTIONS

Construction work must be inspected in accordance with the State Uniform Construction Code Regulations N.J.A.C. 5:23-2.18. This agency will carry out such periodic inspections during the progress of work as are necessary to insure that the work installed conforms with the requirements of the Uniform Construction Code.

The owner or other responsible person in charge of work must notify this agency when work is ready for any required inspections specified below. Requests for inspections must be made at least 24 hours prior to the time the inspection is desired. Inspections will be performed within three business days of the time for which they are requested. The work must not proceed in a manner which will preclude the inspection until it has been made and approval granted.

- Required inspections for all subcodes for one- and two-family dwellings are as follows:
- The bottom of footing trenches before placement of footings, except that in cases of pile foundations, inspections shall be made in accordance with the requirements of the building subcode.
 - Foundations and all walls up to grade level prior to back filling.
 - All structural framing, connections, wall and roof sheathing and insulation; electrical rough wiring, panel and service installation; rough plumbing. The framing inspection shall take place after the rough electrical and plumbing inspections and after the installation of the heating, ventilation and /or air conditioning duct system. The insulation inspection shall be performed after all other subcode rough inspections and prior to the installation of any interior finish material.
 - Installation of all finished materials, sealings of exterior joints, plumbing piping, trim and fixtures; electrical wiring, devices and fixtures; mechanical systems equipment.

Additional required inspections for all subcodes of construction, for other than one- and two-family dwellings, are fire suppression systems, heat producing devices and Barrier Free subcode accessibility, if applicable.

- Required special inspections. The applicant by accepting the permit will be deemed to have consented to these requirements:
- A final inspection is required for each applicable subcode area before a final Certificate of Occupancy or Approval may be issued. The final inspections include the installation of all interior and exterior finish materials, sealing of exterior joints, mechanical system and other required equipment; electrical wiring, devices and fixtures; plumbing pipes, trim and fixtures; tests required by any provision of the adopted subcodes, Barrier Free accessibility, if applicable; and verification of compliance with NJAC 5:23-3.5, "Posting structures".

- A complete copy of released plans must be kept on the job site.

If you do not understand any of this information, please ask.

Appendix C:

Municipal Records: Township Engineer



Township Of Teaneck

PAUL A. VOLCKER
MUNICIPAL GREEN
TEANECK, NEW JERSEY 07666
(201) 837-1600
E-MAIL: admin@teanecknj.gov
WEBSITE: www.teanecknj.gov

October 19, 2021

22 W Englewood Ave LLC
22 W Englewood Ave
Teaneck, New Jersey 07666

Re: Notice of Violation
22 W Englewood Ave
Block 4905 – Lot 8

Sent to Health
Department
3/10/22

Dear: To Whom It May Concern:

It has come to the Township's attention the sidewalks abutting your property need repair and/or replacement of four slabs.

Please be advised, according to sections 32-30 and 32-31 of the code of the Township of Teaneck, the property owner is responsible for any sidewalk deficiencies. This work can be completed by you or a licensed contractor (list is attached). If tree roots are involved, the DPW will perform the cutting back of the tree roots, as this can only be done by the Township employees. The cutting of tree roots can be scheduled at the time the permit is obtained.

A permit must be obtained from the Engineering Office at the Municipal Building prior to commencement of work. All work must be done in accordance with the requirements of the Township.

The repair/replacement of these sidewalks is to be completed by November 26, 2021. If those deficiencies are not completed within the time provided you may be subjected to Municipal Court action.

If you have any questions, please contact my office at 201-837-1600, ext.1728.

Sincerely,
Farah Gilani (GI)
Farah Gilani, P.E., C.M.E., P.P.
Township Engineer

FG/gi
cc: Dean Kazinci, Township Manager
Kevin Arahill, Director, DPW
Gina Miranda Diaz, Health Officer
Travon Romeo, Assistant Superintendent, DPW



Printed on Recycled Stock



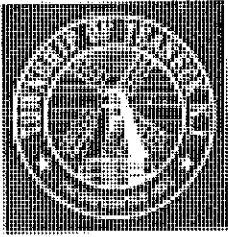

Township Of Teaneck

PAUL A. VOLCKER
MUNICIPAL GREEN
TEANECK, NEW JERSEY 07666
(201) 837-1600
E-MAIL: admin@teanecknj.gov
WEBSITE: www.teanecknj.gov

November 9, 2020

Elie Katz
22 W Englewood Ave
Teaneck, New Jersey 07666

Re: Notice of Violation
22 W Englewood Ave
Block 4905 – Lot 8

Dear Elie Katz:

It has come to the Township's attention the sidewalks abutting your property are in need of repair and/or replacement of four slabs.

Please be advised that, according to Sections 32-30 and 32-31 of the Code of the Township of Teaneck, the property owner is responsible for any sidewalk deficiencies. This work can be completed by you or a licensed contractor (list attached). If tree roots are involved, the DPW will perform the cutting back of the tree roots, as this can only be done by Township employees. The cutting of tree roots can be scheduled at the time the permit is obtained.

A permit must be obtained from the Engineering Office at the Municipal Building prior to commencement of work. All work must be done in accordance with the requirements of the Township.

The repair/replacement of these sidewalks is to be completed by November 30, 2020 or April 30th. If these deficiencies are not completed within the time provided you may be subject to Municipal Court action.

If you have any questions, please contact my office at 201-837-1600, ext. 1728.

Sincerely,

Farah Gilani (GI)

Farah Gilani, P.E., C.M.E., P.P.
Township Engineer

FG/gi

cc: Dean Kazinci, Township Manager
Kevin Arahill, Director, DPW
Ken Katter, Health Officer
Travon Romeo, Assistant Superintendent, DPW



Printed on Recycled Stock





Township Of Teaneck

PAUL A. VOLCKER
MUNICIPAL GREEN
TEANECK, NEW JERSEY 07666
(201) 837-1600
E-MAIL: admin@teanecknj.gov
WEBSITE: www.teanecknj.gov

October 19, 2021

26 W Englewood Ave LLC
26 W Englewood Ave
Teaneck, New Jersey 07666

Re: Notice of Violation
26 W Englewood Ave
Block 4905 - Lot 7

Dear: To Whom It May Concern:

It has come to the Township's attention the sidewalks abutting your property need repair and/or replacement of four slabs.

Please be advised, according to sections 32-30 and 32-31 of the code of the Township of Teaneck, the property owner is responsible for any sidewalk deficiencies. This work can be completed by you or a licensed contractor (list is attached). If tree roots are involved, the DPW will perform the cutting back of the tree roots, as this can only be done by the Township employees. The cutting of tree roots can be scheduled at the time the permit is obtained.

A permit must be obtained from the Engineering Office at the Municipal Building prior to commencement of work. All work must be done in accordance with the requirements of the Township.

The repair/replacement of these sidewalks is to be completed by November 26, 2021. If those deficiencies are not completed within the time provided you may be subjected to Municipal Court action.

If you have any questions, please contact my office at 201-837-1600, ext.1728.

Sincerely,
Farah Gilani (EG)
Farah Gilani, P.E., C.M.E., P.P.
Township Engineer

FG/gj
cc: Dean Kazinci, Township Manager
Kevin Arahill, Director, DPW
Gina Miranda Diaz, Health Officer
Travon Romeo, Assistant Superintendent, DPW

SENT TO
Health Department
3/16/22



Printed on Recycled Stock





Township Of Teaneck

PAUL A. VOLCKER
MUNICIPAL GREEN
TEANECK, NEW JERSEY 07666
(201) 837-1600
E-MAIL: admin@teanecknj.gov
WEBSITE: www.teanecknj.gov

November 9, 2020

Kayla Real Estate LLC
26 W Englewood Ave
Teaneck, New Jersey 07666

Re: **Notice of Violation**
26 W Englewood Ave
Block 4905 – Lot 7

Dear Kayla Real Estate LLC:

It has come to the Township's attention the sidewalks abutting your property are in need of repair and/or replacement of four slabs.

Please be advised that, according to Sections 32-30 and 32-31 of the Code of the Township of Teaneck, the property owner is responsible for any sidewalk deficiencies. This work can be completed by you or a licensed contractor (list attached). If tree roots are involved, the DPW will perform the cutting back of the tree roots, as this can only be done by Township employees. The cutting of tree roots can be scheduled at the time the permit is obtained.

A permit must be obtained from the Engineering Office at the Municipal Building prior to commencement of work. All work must be done in accordance with the requirements of the Township.

The repair/replacement of these sidewalks is to be completed by November 30, 2020 or April 30th. If these deficiencies are not completed within the time provided you may be subject to Municipal Court action.

If you have any questions, please contact my office at 201-837-1600, ext. 1728.

Sincerely,

Farah Gilani

Farah Gilani, P.E., C.M.E., P.P.
Township Engineer

FG/gi

cc: Dean Kazinci, Township Manager
Kevin Arahill, Director, DPW
Ken Katter, Health Officer
Travon Romco, Assistant Superintendent, DPW



Printed on Recycled Stock

